

2004

Can We Predict Joint Effects Of Hypoxia And Metals On Fish Survival?

Michael C. Newman
Virginia Institute of Marine Science

Follow this and additional works at: <https://scholarworks.wm.edu/vimsbooks>



Part of the [Aquaculture and Fisheries Commons](#), and the [Environmental Monitoring Commons](#)

Recommended Citation

Newman, Michael C., "Can We Predict Joint Effects Of Hypoxia And Metals On Fish Survival?" (2004).
VIMS Books and Book Chapters. 15.
<https://scholarworks.wm.edu/vimsbooks/15>

This Book Chapter is brought to you for free and open access by the Virginia Institute of Marine Science at W&M ScholarWorks. It has been accepted for inclusion in VIMS Books and Book Chapters by an authorized administrator of W&M ScholarWorks. For more information, please contact scholarworks@wm.edu.

**FISH PHYSIOLOGY, TOXICOLOGY,
AND WATER QUALITY**

Proceedings of the Seventh International
Symposium, Tallinn, Estonia
May 12-15, 2003

Edited By

Gretchen Rupp and Michelle D. White
Montana Water Center
Montana State University
Bozeman, Montana 59717

Published by

Ecosystems Research Division
Athens, Georgia 30605

National Exposure Research Laboratory
Office of Research and Development
U.S. Environmental Protection Agency
Research Triangle Park, North Carolina 27711

CAN WE PREDICT JOINT EFFECTS OF HYPOXIA AND METALS ON FISH SURVIVAL?

Michael C. Newman¹

ABSTRACT

Fish are suddenly exposed to hypoxic conditions during diverse events such as seiche- or turnover-related water movements, bottom water release from reservoirs, ice-over of eutrophic arctic lakes, and rapid shifts in respiration: photosynthesis associated with cultural eutrophication. In each case, chemical equilibria established under hypoxic conditions that result in metal dissolution and accumulation suddenly shift toward chemical equilibria of oxic conditions. Critical changes in speciation include those determining the free ion activity that, as expressed by the Free Ion Activity Model (FIAM), is often the most bioactive form of a dissolved metal. Metal phase can also change rapidly and, in some cases, result in a precipitate on respiratory surfaces. Exposure of fish gills to metal (and integument of larval or small fish) changes O₂ exchange dynamics. Changes in mucus quality and production and lamellae morphology decrease the amount of effective gill exchange surface and increase the diffusive layer thickness. These changes exacerbate those associated with the reduced O₂ partial pressure gradient. Consequent shifts in blood chemistry (*e.g.*, pH and ion composition) and ventilation also affect metal transport and deposition within fish tissues. Some of these changes have immediate consequences, but others can continue for long periods after the hypoxic conditions pass. Long-term metal effects can influence fish tolerance during future hypoxic episodes.

A joint, similar action model can be applied if the parsimonious assumption is made that asphyxiation constitutes a common mode-of-action for both acute metal effects and hypoxia. Joint action models are applicable based on either conventional dose-effect or survival time approaches. Expansion of such models to a physiologically-based toxicokinetics-toxicodynamics framework (*e.g.*, framed around the Fick equation) would be desirable, provided that model parameter requirements remain realistic. Long-term effects may be better addressed with models such as the binary logistic models used by epidemiologists.

¹ College of William & Mary's Virginia Institute of Marine Science, Department of Coastal & Ocean Policy, P.O. Box 1346, Rt. 1208 Grete Road, Gloucester Point, VA 23062

BACKGROUND

Metal Effects

Metal toxicity to fish is influenced by biogeochemical, cellular, physiological, and anatomical factors. Many of these factors are also influenced by hypoxia.

Metals released from solid phases under anoxic conditions accumulate through time and, during physical mixing with oxic waters, participate in complex chemical reactions. Some (*e.g.*, iron and manganese) can form colloidal phases, and potentially irritate fish gill surfaces. Speciation shifts for other metals that remain in the dissolved phase can elevate free metal ion activity.

Exposure of fish gills to dissolved or colloidal metals can alter gas exchange, ammonia excretion, and ion and osmotic regulation. Irritation from colloids can increase mucus production and, consequently, lower the diffusion rate of gases across the gills. According to Leland and Kuwabara (1985), production and coagulation of excess mucus during acute exposure to dissolved metals results in asphyxiation, *i.e.*, the “coagulation film anoxia hypothesis” for metal lethality. Spaces between primary and secondary gill lamellae fill with coagulated mucus (Figure 1), increasing the effective diffusion distance. For example, colloidal aluminum precipitation on fish gills causes excessive mucus secretion that clogs interlamellar spaces (Poléo 1995).

Metals can also cause swelling of the gill epithelium, a general filling-in between the secondary lamellae, and an increase in numbers of chloride cells. The epithelium of the secondary lamellae, which is composed of two cell layers separated by an intercellular lymphoid space, swells within the lymphoid space to separate the two cell layers. Necrosis and inflammation can also occur (Daoust *et al.* 1984). Blasco *et al.* (2000) noted fusion of secondary lamellae during copper exposure in the Senegalese sole. Jagoe *et al.* (1996) observed thickening of the primary lamellar epithelium to such an extent that the secondary lamellae appeared absent on gills of mercury-exposed mosquitofish, greatly reducing the area available for O₂ exchange. The chloride cell volume density increased with mercury exposure at the expense of pavement cells and, because chloride cells are involved more in ion regulation than with gas exchange, the available gill area for effective respiratory exchange decreased. Chloride cell proliferation can also increase the thickness of the blood-to-water diffusion barrier (Perry 1998) and, as a consequence, impair O₂ diffusion (Greco *et al.* 1995). In turn, these changes produce shifts in ventilation (elevated ventilation amplitude and generally depressed ventilation frequency (Bindon *et al.* 1994). However, Witters *et al.* (1996) noted increased ventilation frequency for brown trout experiencing acute respiratory stress due to aluminum polymerization on their gills. Blood chemistry also shifts.

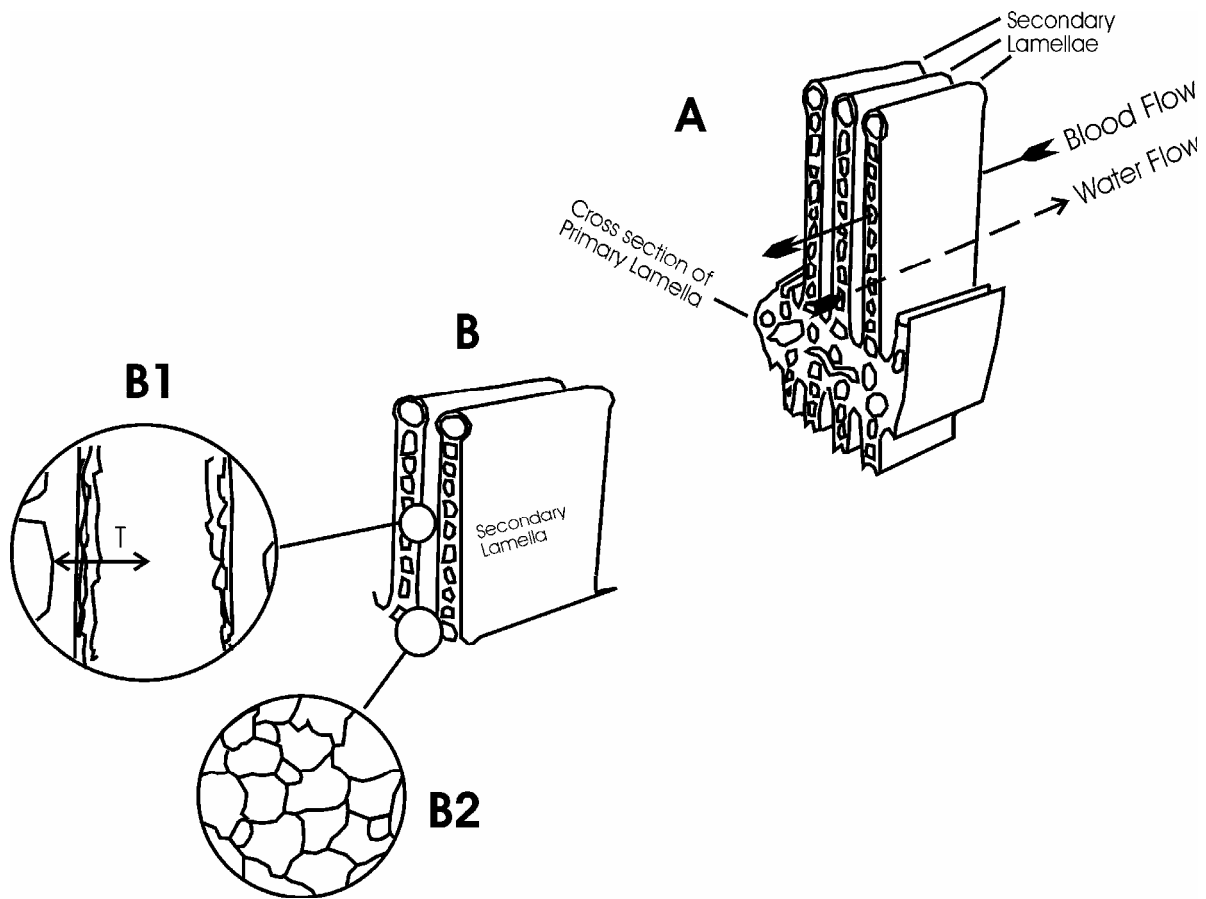

Figure 1. Teleost gill structure. A. Cross section of a primary lamella with three secondary lamellae extending at right angles (upward) from it. Secondary lamellae also extend downward but, in this panel, are not shown completely. Water drawn in via ventilation passes along the surface of each secondary lamella and blood within the lamella flows in the opposite direction (modified from Figure 3 of Randall (1982)). B. Two secondary lamellae with magnified areas B1 and B2. B1. Interlamellar space within which O_2 bearing water passes over the exchange surfaces of the lamellae. Each lamella has a mucus layer and specified thickness. The diffusion distance (T) influences the O_2 diffusion rate across the gill. B2. Cells covering the lamellae. Here cells at the junction of the primary and secondary lamellae are depicted. The pavement cells (white) are the principle cells involved in O_2 exchange. The larger and thicker chloride cells (dark) are involved primarily with ion regulation. Although not depicted, mucus-producing cells on the gill also respond to metal exposure. Pillar cells also reduce the gill area for O_2 exchange. Evans (1998) estimates that as much as 30% of the gill surface is directly above pillar cells and unavailable for respiratory exchange.

Hypoxia Effects

Abrupt exposure to hypoxic conditions results in predictable changes in respiration as the fish adjusts to the change in the O₂ partial pressure gradient across the gill. Initially, ventilation and general activity level change in an attempt to maintain adequate oxygen delivery to tissues (Wu 2002). An extreme example is the eelpout, which becomes immobile under hypoxic conditions (Fischer *et al.* 1992). As an example of change in ventilation, Randall (1982) reports that gill water flow of dogfish is inversely related to arterial O₂ concentration. Increased ventilation volume is generally achieved by large changes in ventilatory stroke volume and smaller changes in ventilation frequency (Gilmour 1998), suggesting respiratory impairment; water softness-induced increases in chloride cells also results in elevated ventilation stroke volume and lowered ventilation frequency (Bindon *et al.* 1994). Heart stroke volume can increase and heart rate decrease under hypoxic conditions (Randall 1982). These changes are energetically efficient, short-term means of coping with hypoxia.

Other compensatory responses to hypoxia can enhance O₂ diffusion rates (Gilmour 1998). Changes in ventilation and thinning of the epithelium due to increased blood pressure tend to reduce the O₂ diffusion barrier thickness. Increased water and blood flow can also modify the difference in O₂ partial pressures across the gill.

Joint Effects of Hypoxia and Metals

There is a commonality in the effects on fishes from hypoxia and metals: asphyxiation. This can be easily described with Fick's model for O₂ diffusion rate (dO₂/dt) (Table 1):

$$\frac{dO_2}{dt} = A \cdot K_{O_2} \cdot \frac{\Delta P_{O_2}}{T}$$

where ΔP_{O_2} = difference in O₂ partial pressures across the gill diffusional barrier, K_{O_2} = gill barrier diffusion coefficient, A = the effective diffusion area of the gills, and T = the diffusion barrier thickness. By definition, hypoxia changes the gill partial pressure differential (ΔP_{O_2}). Modifications to ventilation and cardiac dynamics have the purpose of minimizing changes to this differential. The gill barrier diffusion coefficient (K_{O_2}) can be increased by mucus and metal precipitates. The morphological changes to primary and secondary lamellae can decrease the effective diffusion area (A). Combined, the morphological changes and mucus increase the diffusion barrier thickness.

Table 1. Effects summary for hypoxia and acute metal exposures contributing to asphyxiation. Terms in the left column are those of Fick's equation for O₂ diffusion rate.

Term	Hypoxia	Acute Metal Exposure
A (effective diffusion area)	Increased slightly	Decreased
K_{O2} (diffusion coefficient)	Decreased slightly	Increased
ΔP_{O2} (partial pressure difference)	Greatly increased	None
T (diffusion barrier thickness)	Decreased slightly	Increased

Both acute metal exposure and hypoxia reduce the O₂ diffusion rate across the gills. Some metal-induced changes, such as excessive mucus production, might be coincident with those changes associated with hypoxia. A sudden release of hypoxic, metal-rich water from a lake hypolimnion is one situation in which this might occur. In one of many such situations, Baden *et al.* (1995) described the simultaneous exposure of decapods to low oxygen and high manganese conditions during periodic autumnal hypoxia resulting from coastal eutrophication. Some metal-induced changes in gill morphology could occur prior to the hypoxic event of concern and predispose an individual to succumb more quickly. Any exposure to high metal concentration (or soft water (Greco *et al.* 1995, Perry 1998)) prior to a low oxygen event could do this.

MODELING JOINT METAL-HYPOXIA MORTALITY

Assuming that asphyxiation has a common mode-of-action suggests the application of similar joint action models to predict the combined effects of low O₂ and high metal conditions. For concentration-effect experiments in which the proportion of exposed individuals that die is scored at a set exposure duration, a general approach exists for incorporating the joint effects of two or more similarly acting stressors. Finney (1947) established this approach by first observing that similarly acting stressors often have concentration-response curves with identical slopes (b).

$$\text{Probit}(P_1) = a_1 + b (\log C_1)$$

$$\text{Probit}(P_2) = a_2 + b(\log C_2)$$

where, P₁ and P₂ = proportions dying after exposure to stressor 1 or 2, a₁ and a₂ = intercepts for stressors 1 and 2, and C₁ and C₂ = concentrations for stressors 1 and 2.

By combining and then re-arranging these equations, the joint effect of the two stressors (Probit ($P_1 + P_2$)) can be predicted for the binary mixture.

$$\log \phi_2 = \frac{a_2 - a_1}{b}$$

$$\text{Probit}(P_1 + P_2) = a_1 + b(\log C_1 + \phi_2(\log C_2))$$

Unfortunately, this conventional model is not directly applicable because the slope for the metal concentration-effect model would be positive and that for the O_2 concentration-effect model would be negative. That is, mortality increases as metal concentration increases or as O_2 concentration decreases. Despite a deviation from convention, the two probit models can be combined and successfully rearranged. Specifically, the O_2 concentration can be expressed as the absolute deviation from normoxic O_2 concentration. The slope for the O_2 concentration-effect model would then be positive.

A more direct model formulation might be possible if a common, physiologically-based metric of stressor intensity were available. Fick's equation suggests O_2 diffusion rate might be the most appropriate metric that reflects the common effect of both low O_2 and high metal concentrations.

$$\text{logit}(P) \text{ or } \text{Probit}(P) = a + b_1 \left(\log \frac{dO_2}{dt} \right)$$

The O_2 diffusion rate would be estimated with Fick's equation. This model is likely to be appropriate only below a threshold O_2 diffusion rate; thus a threshold value might also need to be estimated. The threshold would reflect the minimum O_2 diffusion rate below which the tissue O_2 demands are not met. A physiologically-based, toxicokinetics-toxicodynamics model could facilitate such a formulation but, in many cases, would likely require more parameter estimates than one has the resources and time to generate.

Instead, a simpler logistic or probit model could be applied with O_2 and metal concentrations as covariates (C_1 and C_2). The coefficients (b_1 and b_2) would have opposite signs in this case. The O_2 concentrations for which the model would be appropriate would be those below some minimum threshold, *i.e.*, below normoxic conditions. Such a model would not strictly require a common mode-of-action.

$$\text{logit}(P) \text{ or } \text{Probit}(P) = a + b_1(\log C_1) + b_2(\log C_2)$$

Choosing between the logistic (logit) and normal (probit) models would require a goodness-of-fit statistic such as the χ^2 statistic. Although log transformations of both concentration variables are shown here, a χ^2 statistic could also be used to select the best transformations of concentrations. Whether expressed as a logit or probit model, the model could include an interaction term if warranted.

$$\text{logit}(P) \text{ or } \text{Probit}(P) = a + b_1(\log C_1) + b_2(\log C_2) + b_{12}(\log C_1 \cdot \log C_2)$$

These same models could be used if previous metal exposure had occurred and the deaths associated with an hypoxic event were to be predicted. The fish might be classified with a categorical variable relative to whether it had or had not been previously exposed to high metal concentrations. This common approach taken by epidemiologists (*e.g.*, Ahlbom 1993) to estimate relative risks for etiological factors would allow one to estimate the increase in risk of mortality under hypoxic conditions as a function of past metal exposure. The logistic model including log O₂ concentration and the categorical variable (previously exposed to metal or not) would be the following:

$$\text{Logit}(P) = \ln\left(\frac{P}{1-P}\right) = a + b_1(\log C_1) + b_2(E)$$

where P = proportion of individuals exposed to hypoxic conditions that die, a = intercept, b₁ = coefficient for the effect of log O₂ concentration, C₁ = oxygen concentration, b₂ = coefficient for metal exposure status effect, and E = a categorical score denoting whether an individual had (1) or had not (0) been previously exposed to high concentrations of metal. The risk of an individual previously exposed to metal relative to that of an individual with no previous metal exposure would be the following (modified from Ahlbom (1993)),

$$e^{b_2} = \frac{\frac{P_e}{1-P_e}}{\frac{P_n}{1-P_n}} = RR$$

where P_e and P_n = the proportion of individuals dying during hypoxic exposure with previous metal exposure (e) and non-previous metal exposure (n) respectively. The relative risk (RR) can be approximated with the estimated b₂ of the logistic model fit to these data.

Another set of models would be useful if survival time were used as the effect metric instead of the proportion dying by a set time. In such a design, individuals are exposed to lethal conditions and the time required to die for each individual is recorded. A rich array of survival time methods is available (see Newman 1995 and Crane *et al.* 2002). Most such methods accommodate censoring, *i.e.*, a time-to-death data set in which some individuals were still alive at the end of the exposure. These methods have been applied to separate effects of oxygen (*e.g.*, Dixon and Newman 1991) and metals (*e.g.*, Newman 1995). Roy and Campbell (1995) used these methods for the joint effects of aluminum and zinc on Atlantic salmon juveniles. There is no apparent reason they could not be applied to the joint effects of hypoxia and metal exposure. As a particularly relevant example, Veldhuizen-Tsoerkan *et al.* (1991) concluded from survival time analyses that mussels previously exposed to metals were less tolerant of anoxia. For this metric, simple parametric models can be generated.

$$\ln TTD = a + b_1(\log C_1) + b_2(\log C_2) + \varepsilon$$

where TTD = time-to-death and ε = an error term that has a specified distribution. Such a simple model could include O₂ and metal concentrations, or some transformation of these concentrations, as covariates to predict time-to-death during acute, joint exposures. If the situation of concern was survival during exposure to hypoxic conditions for fish with different metal exposure histories (*i.e.*, fish with modified gill structure), a similar model could be applied in which O₂ concentration was included as a continuous variable and past metal exposure status was included as a categorical variable.

CONCLUSION

The parsimonious assumption that asphyxiation is a common mode-of-action for both hypoxia and metal toxicity suggests that a wide range of models could be used to predict the combined effects of hypoxia and high metal concentrations (Figure 2). Such models were described for two relevant scenarios. The first is the simultaneous exposure of fish to high metal and low O₂ concentrations. This might occur during the sudden mixing of oxic and anoxic waters. The second scenario involves an initial exposure to metals resulting in gill morphology changes that make individuals more susceptible to the lethal effects of hypoxia. This might occur in fish surviving a hypoxic/high metal event that are exposed again to low O₂ conditions.

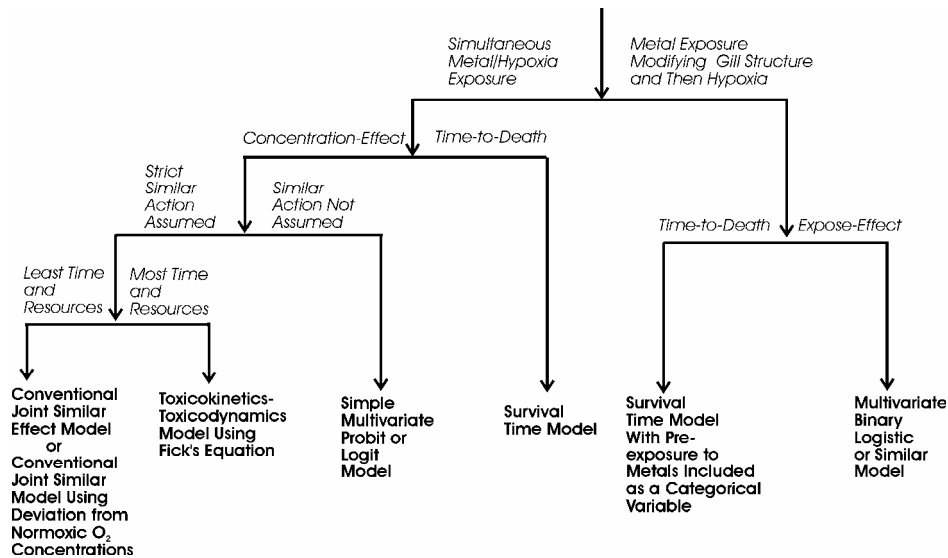

Figure 2. A summary of the potentially useful models for predicting the combined effect of hypoxia and elevated metal concentrations. Models are separated into those dealing with simultaneous exposure to low O₂ and high metal concentrations, and those dealing with low O₂ tolerance after fish gills have been modified during a previous exposure to high metal concentrations. Models that can be derived using conventional concentration-effect or time-to-death data are also shown.

Models for both scenarios were discussed for data sets from conventional concentration-effect and survival time experiments. A wide array of plausible models exists, suggesting that predictive models can be developed for the combined effects of hypoxia and high metal concentrations. However, deciding which model will be the most effective requires the application of candidate models to other appropriate data sets.

REFERENCES

- Ahlbom, A. 1993. *Biostatistics for Epidemiologists*. CRC/Lewis Press. Boca Raton, FL.
- Arllano, J.M., J. Blasco, J.B. Ortiz, D. Capeta-Da Silva, A. Navarro, M.J. Sanchez-Cel Pino, and C. Sarasquete. 2000. Accumulation and histopathological effects of copper in gills and liver of Senegales sole, *Solea senegalensis* and toad fish, *Halobatrachus didactylus*. *Ecotoxicology and Environmental Restoration* 3:22-28.
- Baden, S.P., S.P. Eriksson, and J.M. Weeks. 1995. Uptake, accumulation and regulation of manganese during experimental hypoxia and normoxia by the decapod *Nephrops norvegicus* (L.). *Marine Pollution Bulletin* 31:93-102.
- Bindon, S.D., K.M. Gilmour, J.C. Fenwick, and S.F. Perry. 1994. The effects of branchial chloride cell proliferation on respiratory function in the rainbow trout *Oncorhynchus mykiss*. *Journal of Experimental Biology* 197: 47-63.
- Crane, M., M.C. Newman, P.F. Chapman, and J. Fenlon. 2002. *Risk Assessment with Time to Event Models*. Lewis/CRC Press. Boca Raton, FL.
- Daoust, P.Y., G. Wobeser, and J.D. Newstead. 1984. Acute pathological effects of inorganic mercury and copper in gills of rainbow trout. *Veterinary Pathology* 21:93-101.
- Dixon, P.M., and M.C. Newman. 1991. Analyzing toxicity data using statistical models for time-to-death: an introduction. *In: Metal Ecotoxicology, Concepts & Applications*, M.C. Newman and A.W. McIntosh, (eds). CRC/Lewis Press. Boca Raton, FL. pp. 207-242.
- Evans, D.H. 1998. *The Physiology of Fishes*, Second Edition. CRC Press. Boca Raton, FL.
- Finney, D.J. 1947. *Probit Analysis: A Statistical Treatment of the Sigmoidal Response Curve*. Cambridge University Press. Cambridge, UK.
- Fischer, P., K. Rademacher, and U. Kils. 1992. In situ investigations on the respiration and behavior of the eelpout *Zoarces viviparus* under short term hypoxia. *Marine Biology Letters* 2:345-351.

- Gilmour, K.M. 1998. Gas exchange. *In: The Physiology of Fishes*, Second Edition, D.H. Evans (ed). CRC Press. Boca Raton, FL. pp. 101-127.
- Greco, A.M., K.M. Gilmour, J.C. Fenwick, and S.F. Perry. 1995. The effects of softwater acclimation on respiratory gas transfer in the rainbow trout *Oncorhynchus mykiss*. *Journal of Experimental Biology* 198:2557-2567.
- Jago, C.H., A. Faivre, and M.C. Newman. 1996. Morphological and morphometric changes in the gills of mosquitofish (*Gambusia holbrooki*) after exposure to mercury (II). *Aquatic Toxicology* 34:163-183.
- Leland, H.V. and J.S. Kuwabara. 1985. Trace Metals. *In: Fundamentals of Aquatic Toxicology*, G.M. Rand and S.R. Petrocelli, (eds). Hemisphere Publishing Corp. Washington, DC. pp. 374-415.
- Newman, M.C. 1995. *Quantitative methods in Aquatic Ecotoxicology*. Lewis/CRC Press. Boca Raton, FL.
- Perry, S.F. 1998. Relationships between branchial chloride cells and gas transfer in freshwater fish. *Comparative Biochemistry and Physiology* 119A:9-16.
- Poléo, A.B.S. 1995. Aluminum polymerization – a mechanism of acute toxicity of aqueous aluminum to fish. *Aquatic Toxicology* 31:347-356.
- Randall, D. 1982. The control of respiration and circulation in fish during exercise and hypoxia. *Journal of Experimental Biology* 100:275-288.
- Roy, R. and P.G.C. Campbell. 1995. Survival time modeling of exposure of juvenile Atlantic salmon (*Salmon salar*) to mixtures of aluminum and zinc in soft water at low pH. *Aquatic Toxicology* 33:155-176.
- Veldhuizen-Tsoerkan, M.B., D.A. Holwerda, and D.I. Zandee. 1991. Anoxic survival time and metabolic parameters as stress indices in sea mussels exposed to cadmium or polychlorinated biphenyls. *Archives of Environmental Contamination and Toxicology* 20:259-265.
- Witters, H.E., S. Van Puymbroeck, A.J.H.X. Stouthart, and S.E. Wendelaar Bonga. 1996. Physicochemical changes of aluminum in mixing zones: mortality and physiological disturbances in brown trout (*Salmo trutta* L.). *Environmental Toxicology & Chemistry* 15:986-996.
- Wu, R.S.S. 2002. Hypoxia: from molecular responses to ecosystem responses. *Marine Pollution Bulletin* 45:35-45.