

Reports

---

3-1993

## **An Evaluation of Processed Atlantic Sea Scallops (*Placopecten magellanicus*)**

William D. DuPaul  
*Virginia Institute of Marine Science*

W. Steven Otwell  
*University of Florida*

Thomas Rippen  
*Virginia Sea Grant Extension Program*

Follow this and additional works at: <https://scholarworks.wm.edu/reports>



Part of the [Aquaculture and Fisheries Commons](#)

---

### **Recommended Citation**

DuPaul, W. D., Otwell, W. S., & Rippen, T. (1993) An Evaluation of Processed Atlantic Sea Scallops (*Placopecten magellanicus*). Marine Resource Report No. 93-1. Virginia Institute of Marine Science, College of William and Mary. <http://dx.doi.org/doi:10.21220/m2-ravz-1j34>

This Report is brought to you for free and open access by W&M ScholarWorks. It has been accepted for inclusion in Reports by an authorized administrator of W&M ScholarWorks. For more information, please contact [scholarworks@wm.edu](mailto:scholarworks@wm.edu).

**An Evaluation of Processed Atlantic Sea Scallops  
(Placopecten magellanicus)**

William D. DuPaul  
Robert A. Fisher  
College of William and Mary  
Virginia Institute of Marine Science  
Virginia Sea Grant Marine Advisory Program

W. Steven Otwell  
University of Florida  
Food Science and Human Nutrition Department  
Florida Sea Grant College Program

Thomas E. Rippen  
Virginia Polytechnic Institute and State University  
Virginia Cooperative Extension  
Virginia Sea Grant Marine Advisory Program

conducted for

**The American Scallop Association  
P.O. Box 8933  
New Bedford, MA 02740**

and

**The International Food Additives Council  
5775 Peachtree Dunwoody Road  
Atlanta, GA 30342**

March 1993

Virginia Marine Resource Report #93-1  
Virginia Institute of Marine Science  
College of William and Mary  
Gloucester Point, VA 23062

## TABLE OF CONTENTS

Acknowledgements .....	i
Introduction .....	1
Background .....	1
Research Plan .....	2
Section 1. Vessel Operations .....	5
Methods and Results .....	5
Supplemental Moisture and Protein Data .....	7
Figures 1 - 2 .....	8
Tables 1 - 5 .....	10
Section 2. Sampling and Processing .....	15
Methods .....	15
Analytical Methodology .....	16
Results and Discussion .....	18
Processing .....	18
Moisture and Weight Change .....	19
Phosphate Incorporation .....	21
Aerobic Plate Counts .....	22
Nutritional Equivalency .....	23
Conclusions .....	26
Processing .....	26
Nutritional Equivalency .....	26
Tables 6 - 14 .....	27

Section 3. Iced Storage Study .....	36
Objectives .....	36
Methods .....	36
Procedures .....	37
Sensory Panel Procedures .....	38
Statistical Analysis .....	38
Results and Discussion .....	39
Moisture .....	39
pH .....	40
Aerobic Plate Counts .....	40
Drip Loss .....	41
Cook Loss .....	41
Sensory Analysis .....	42
Conclusions .....	43
Figures 3 - 14 .....	45
Section 4. Consumer Discrimination and Preference of Phosphated Scallops .....	57
Methods .....	57
Results and Discussion .....	58
Conclusions .....	61
Tables 15 - 21 .....	62
References .....	69
Appendix 1 .....	72
Appendix 2 .....	78
Appendix 3 .....	101
Appendix 4 .....	105
Appendix 5 .....	106
Appendix 6 .....	107

Appendix 7 .....	124
Appendix 8 .....	126

## ACKNOWLEDGEMENTS

The following study could not have been completed without the advice and help of many people associated with the fishing industry and participating Universities.

In particular, the authors would like to acknowledge the efforts of Roy Martin and Bob Collette of the National Fisheries Institute in bringing together members of the scallop industry, the U.S. Food and Drug Administration and academia; Roy Enoksen, Capt. Jim Kendell and the crew of the F/V Nordic Pride for their help in obtaining the scallops used in this study; Pat Hughes and the staff at Eastern Fisheries, New Bedford, Massachusetts for their assistance in the processing plant; Patricia Lacey, Bob Lane, Helen Sutton and Janet Johnson at the Virginia Polytechnic Institute and State University (VPI & SU) for assistance in the design and implementation of the ice storage and organoleptic studies; Grace Battisto of the Nutrient Analysis Laboratory at the Virginia Institute of Marine Science for the proximate analysis study and Lceann Applewhite and Laura Garrido of the Florida Department of Agriculture and Consumer Services stationed with the Department of Food Science and Human Nutrition, University of Florida for their assistance with the consumer preference studies.

A significant amount of staff time was contributed by the authors of this report and by their supporting Institutions. Special acknowledgements of appreciation and recognition go to the Virginia Sea Grant Marine Advisory Program at the Virginia Institute of Marine Science, College of William and Mary and at the Hampton Seafood Experiment Station, VPI & SU, and the Florida Sea Grant Marine Extension Program, Food Science and Human Nutrition Department, University of Florida. Also, sensory consultant Holli Hargett and Market Insight Inc. based in Greenville, South Carolina.

**Data and information contained in this report shall not be used nor referenced without expressed written approval from the authors.**

This work, in part, is a result of research sponsored by NOAA Office of Sea Grant, U.S. Dept. of Commerce under federal grant number NA-90AA-D-SG045 to the Virginia Graduate Marine Science Consortium and the Virginia Sea Grant College Program.

Florida Sea Grant College Program is supported by award of the Office of Sea Grant, NOAA, U.S. Department of Commerce, grant number NA 89AA-D-56053, under provisions of the National Sea Grant College and Programs Act of 1966.

All participating Colleges and Universities are equal opportunity/affirmative action Institutions.

## INTRODUCTION

### Background

The Atlantic sea scallop, Placopecten magellanicus, is harvested from North Carolina to Newfoundland. The U.S. commercial fishery is conducted from the Virginia-North Carolina border to Georges Bank and the Gulf of Maine. The fishery is generally considered as an offshore fishery with most commercial operations conducted on the continental shelf in water depths ranging from 20-45 fathoms except for the near-shore fishery in the Gulf of Maine. Sea scallops are generally harvested by dredge and to a far lesser extent, by otter trawl. Most scallops landed in U.S. ports are shucked at-sea on the harvesting vessels. Crew members cut the scallop meats (adductor muscle) from the shell discarding the remainder overboard. The scallop meats are subsequently washed, bagged and stowed on ice for the duration of the fishing trip. Under certain circumstances involving warm seawater and hot weather, ice is used on the deck of the vessel to chill the scallop meats until bagging.

Upon offloading, scallops are handled in a variety of ways depending on market requirements and preferences. However, most landed sea scallops are washed and/or processed with sodium tripolyphosphate (STP) or other food grade phosphates. The use of phosphates in the processing of muscle foods to minimize water drip or thaw loss and extended shelf-life is a common practice (Molins, 1991). The U.S. Food and Drug Administration (FDA) identified areas of concern with the processing of scallops for extended periods of time in a STP solution. While STP is a Generally Recognized as Safe (GRAS) substance, it must be used in accordance with Good Manufacturing Practices (GMP). Currently, there is no industry-wide or FDA adopted GMP specifically for the handling and processing of Atlantic sea scallops and only a modest amount of information available relative to the functional attributes of STP (ie. moisture retention, increase in shelf-life). In addition, since the use of ice on commercial scallop vessels to maintain product quality is a long standing

practice, it became quite unclear as to the implications of FDA's concern relative to moisture absorbed by scallops during normal handling and stowage procedures in an attempt to establish a GMP.

Late in 1991, members of the U.S. scallop industry met with staff of the FDA's newly formed Office of Seafood (FDA-OS) in an attempt to resolve the concerns expressed by FDA. This meeting was facilitated by the National Fisheries Institute (NFI) and involved individuals from academic institutions currently conducting research in related areas. Consequently, a Sea Scallop Technical Committee was formed to assist industry in gathering pertinent information on sea scallops and the use of condensed phosphates. The first step to develop a concept that could be used to address water uptake and phosphate use from the point of harvest through final processing was completed on January 8, 1992 (Appendix 1). From this document came the framework for developing a GMP for all phases of scallop handling and processing with supporting documentation, rationale and findings (Appendix 2).

In 1992, members of the scallop industry formed the American Scallop Association (ASA) to work with the FDA to further resolve various processing procedures and to support needed research. After review by FDA-OS of the draft GMP, it became obvious that certain questions could only be answered by additional research. Consequently, the Technical Committee was charged to develop a proposal for a research project for the evaluation of processed sea scallops and to address the informational needs of FDA-OS (Appendix 3). In August 1992, funding for this research was made available from the ASA and the International Food Additives Council (IFAC). The objectives of the research project was to evaluate organoleptic parameters, moisture and protein levels, consumer preference, nutritional profiles and moisture retaining characteristics of Atlantic sea scallops processed with STP.

#### Research Plan

The basic concept behind this project was to obtain a suitable quantity of sea scallops from a single source and quantify several parameters important to the handling and processing of scallops. A more detailed explanation of the research plan is presented in Appendix 3 and Figure 1. The plan called for scallops to be



harvested by a vessel from New Bedford, Massachusetts fishing in the area of Georges Bank and the Great South Channel (Figure 2). Fishing operations began on August 28, 1992 and terminated on September 9, 1992. Scallops used for the project were harvested midway through the trip so that the stowage time would be about seven days. This would represent a mid-point or an average stowage time as most vessels were making trips that lasted 14-15 days. Previous work (DuPaul et al 1990, 1991) documented that the uptake of water from ice melt in the hold varied with stowage time. In addition, it has been shown that variables such as temperature, the use of ice on deck, size of scallop meats, stowage time, water uptake by scallop meats and the moisture content of scallops at offloading had significant effects in the processing of scallops (Fisher et al, 1991; DuPaul et al, 1991). As a result, the scallops used for this study had to be harvested within the shortest time possible, be of uniform size and be treated in the same manner from shucking to offloading. Scallops of uniform size was an important consideration for this study since scallop size variability could adversely effect processing consistency, shelflife studies and importantly, the consumer evaluation studies.

Thirty 40-pound bags of scallop meats were harvested over a 36-hour period (six 6-hour watches) from a single resource area off Cape Cod, Massachusetts. Resource conditions at this time were characterized as areas with numerous small scallops (shell height 65-100 mm) to areas with relatively few scallops ranging greatly in size (shell height 75-135 mm). Scallops were shucked, washed in seawater and then held in insulated totes containing a mixture of seawater and ice for three hours prior to bagging. Since seawater temperatures were between 62-65° F, a mixture of seawater and ice was used to pre-chill the scallop meats (Refer to GMP, Appendix 2). Temperature records of scallops were maintained from harvesting through offloading to insure that scallops were kept cold and were of good quality with no chance of compromise through thermal abuse or improper storage temperatures. The bagging of shucked scallop meats occurred at six hour intervals (Refer to GMP, Appendix 2). Bags of scallop meats were then placed in the ice hold and held in a chill-bin for six hours prior to final ice storage. The use of a chill bin, where scallop bags are loosely packed and covered with ice, allows the bags to cool so that when permanently stowed, ice melt around the bag is minimized and prevents air pockets from forming (Refer to GMP, Appendix 2).

Samples of scallop meats were taken shortly after shucking and just prior to bagging for each of the six watches. These samples served as the baseline for natural levels of moisture, protein, carbon and ash and for the nutritional profiles. A similar set of scallop meat samples were taken at offloading for the same analyses.

After offloading, scallops were processed according to the established protocol (Figure 1 and Appendix 3) at a commercial scallop processing plant in New Bedford, Massachusetts using the same procedures and equipment commonly found throughout the industry. At the end of the processing operations, six groups of processed scallops were obtained: three processed with a 2.5% STP and 1.0% sodium chloride solution weight by weight (w/w) each with different moisture levels and processing times, one washed for 20 minutes with water, one washed for 20 minutes in a 4.0% STP and 1.0% sodium chloride solution (w/w) and one washed for 20 minutes in water and then dipped for 1 minute in a 10.0% STP and 1.0% sodium chloride solution (w/w). These six groups comprised the basis for the series of comparative evaluations outlined in Appendix 3.

Fresh scallops were packed in ice and transported to Virginia to conduct the organoleptic and ice storage evaluations, nutritional profiles and moisture retention studies. The parameters measured are described in Appendix 3 and in more detail in the appropriate sections of this report. Frozen scallops were used for the consumer preference studies, organoleptic evaluations, moisture retention studies and nutritional profiles. Scallops were frozen in five pound blocks with a commercial plate freezer and stored at -20° F in commercial cold storage. Details for each of the above mentioned studies are described in Appendix 3 and in the appropriate sections of this study.

## SECTION 1. VESSEL OPERATIONS

### Methods and Results

Sea scallops used for this study were harvested aboard the F/V Nordic Pride during commercial fishing operations conducted in the area of the Great South Channel and southeast of Cape Cod, Massachusetts during the period of August 27 to September 9, 1992 (Figure 2). Scallops were harvested during six 6-hour watches on September 2nd and 3rd in a fishing area selected for uniform sized scallops of sufficient quantity to obtain 1200 pounds of shucked scallop meats in the shortest time possible. A "watch" is referred to as the work interval for crews aboard fishing vessels. Traditionally, scallops are bagged at the end of each watch prior to the crew retiring for meals and rest. Watches can be of six, eight or 12-hour durations with two crews sharing the 24-hour work day.

Scallops were harvested, sorted and shucked according to normal commercial operations. After shucking, scallops were washed in seawater and held in an insulated tote containing a mixture of 4:1 seawater:ice mixture for three hours to pre-chill scallops prior to bagging. Scallops were bagged at the end of each 6-hour watch. The use of an insulated tote on-deck as a holding and pre-chilling container for scallops prior to bagging facilitated the need to control and standardize handling procedures as much as possible. The totes provided cover and protection from weather elements and provided a mechanism to keep scallop meats at a relatively constant temperature. Scallops were bagged and placed in the ice-hold according to normal industry practices. Approximately 40 pounds of scallops were packed in linen sacks and held in a chill-bin for six hours before final stowage in ice. The chill-bin is a separate area in the ice-hold where the most recently bagged scallops are covered with ice for chilling prior to permanent stowage. Stowing unchilled bags can result in undesirable quality attributes, such as discoloration, in scallops during extended fishing trips (DuPaul et al, 1990).

The temperature records of scallops used for this study indicated that scallops were held at the proper and desired temperatures for the duration of the fishing trip and at offloading (Table 1). Temperatures were determined using an Omega HH-51 Digital Thermometer with Type K Chromel-Alumel Thermocouples. Wire thermocouples were inserted into the center of the filled scallop bags at the time of bagging. One bag from each of the six watches was wired. Connector lead wires were of sufficient length to allow temperature determinations to be made for the duration of the trip. Bag temperatures were determined just prior to placement in the chillbin and at 6-hour intervals until the internal temperatures stabilized and then intermittently until the end of the trip. Additionally, temperatures were determined for surface seawater and scallops held in the totes during each of the six watches. The absence of any indication of thermal abuse is one level of assurance that proper on-deck handling and stowage procedures were effective in providing good quality scallops for on-shore processing. Chill tote, bag-up and internal bag temperatures during stowage are within the observed values documented in previous studies (DuPaul et al, 1990). Temperatures at the center of the bag stabilized at around 34-35°F within 24 hours of stowage and remained in that range for the duration of the trip.

Moisture and protein values for sea scallops used in this evaluation were determined at each important step in the harvest, deck handling and stowage operations (Table 2). Methodology for each of the determinations are listed in Appendix 4. For each sample, seven to eight individual scallop meats were patted dry to remove excess water, wrapped tightly at the bottom of a pint Ziploc freezer bag and immediately frozen. A composite tissue homogenate was used for the proximate analysis. Initial moisture and protein content were determined for freshly shucked scallops for each of the six watches and did not vary greatly as fishing operations were concentrated in a small area. The mean value of 77.11% moisture is within the reported range of moisture content for freshly shucked sea scallops of approximately 75-79%. Scallops for this study were not mixed with scallops from other harvest areas.

As expected, the moisture content of the scallop meats increased upon exposure to melting ice water in the chill totes and in the ice-hold during stowage. A mean increase of 1.06% in the chill tote and 1.53% at offloading was recorded. Consequently, the ex-vessel moisture content of the scallops used for this study ranged

from 77.93 to 79.56% with a mean of 78.64%. A moisture content of less than 80% was anticipated based on previous experiences (Refer to GMP, Appendix 2).

#### Supplemental Moisture and Protein Data

Moisture and protein were determined on additional batches or sequences of scallops harvested during fishing operations (Tables 3-5). Although these scallops were not used in this study to evaluate processed sea scallops, the additional information can be useful for purposes of comparison. The three additional sequences of data varies in that the stowage times are different and that two of three involve the mix of scallops from shellstock with freshly harvested scallops. The use of shellstock is often related to resource conditions where there is an abundance of relatively small scallops in a particular area and a scarcity of relatively larger scallops throughout the fishing area. In this operation, scallops were harvested, sorted and placed in bins in the ice-hold. Ice was used to keep the scallops cold until shucking. At 6-hour intervals, a portion of the shellstock was removed from the ice-hold to be shucked along with the scallops being harvested at that time. Consequently, Tables 2 and 3 illustrate moisture and protein values for scallops shucked from stowed shellstock.

It is important to note that for all sequences of data, although moisture content was variable at harvest, and at bagging (ex-tote), average ex-vessel values of moisture content did not exceed 80%. According to scientific literature, it is also common to expect the moisture and protein content of sea scallops to vary according to season, fishing area, depth of water and state of sexual maturity. During this scallop trip, conducted in a limited fishing area and time frame, the initial moisture content of scallops ranged from 74.89 to 77.37% with a mean value of 76.06% (n=21). Initial protein content ranged from 17.11 to 19.88% with a mean value of 18.51% (n=21).

Figure 1

# SCALLOP PROCESSING PROTOCOL FLOW DIAGRAM

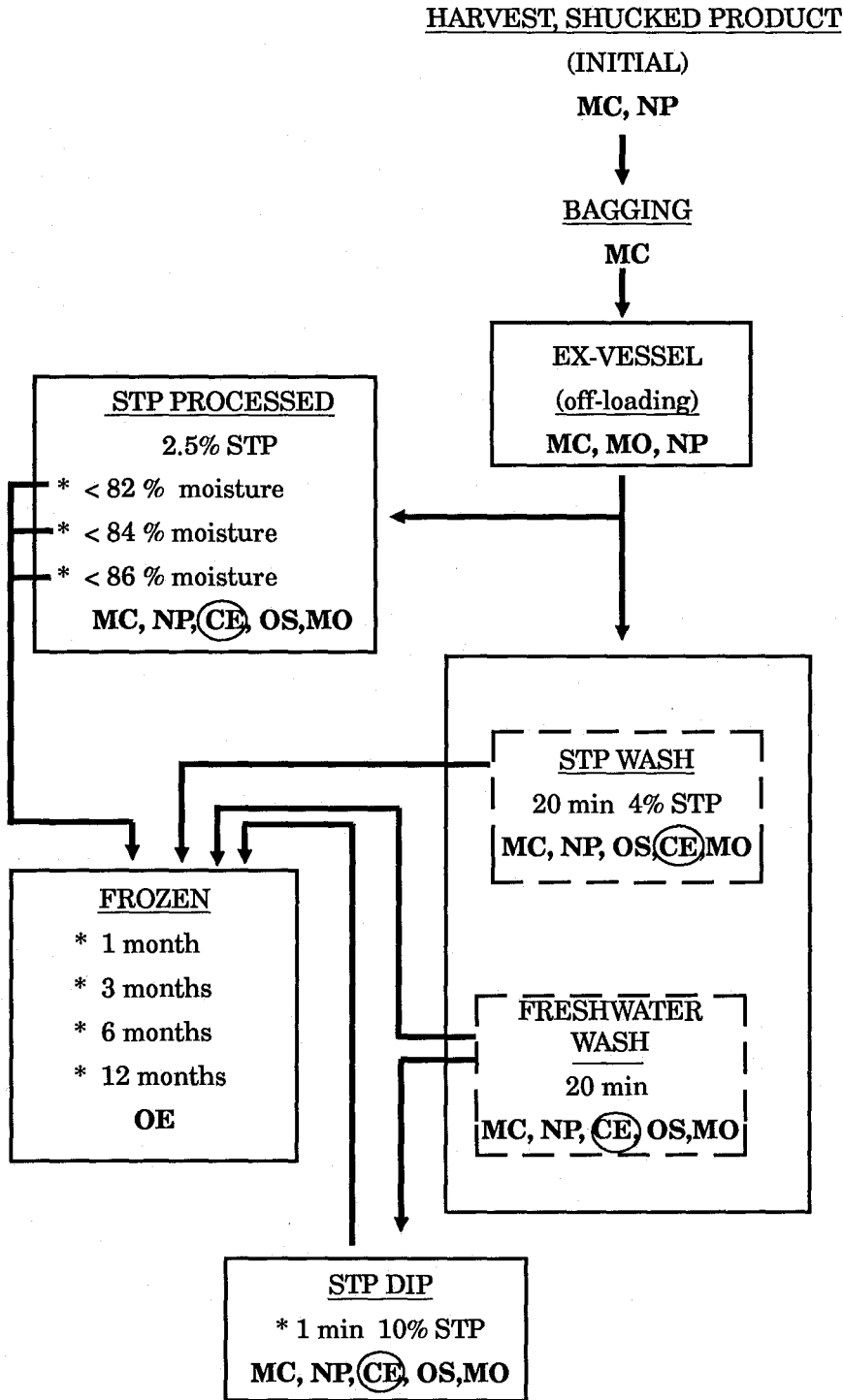

MC = Moisture Content

NP = Nutrition Profile

OS = Organoleptic Evaluation Shelf Life \*

MO = Microbiological Evaluation

CE = Consumer Evaluation (frozen)

OE = Organoleptic Evaluation

FIGURE 2

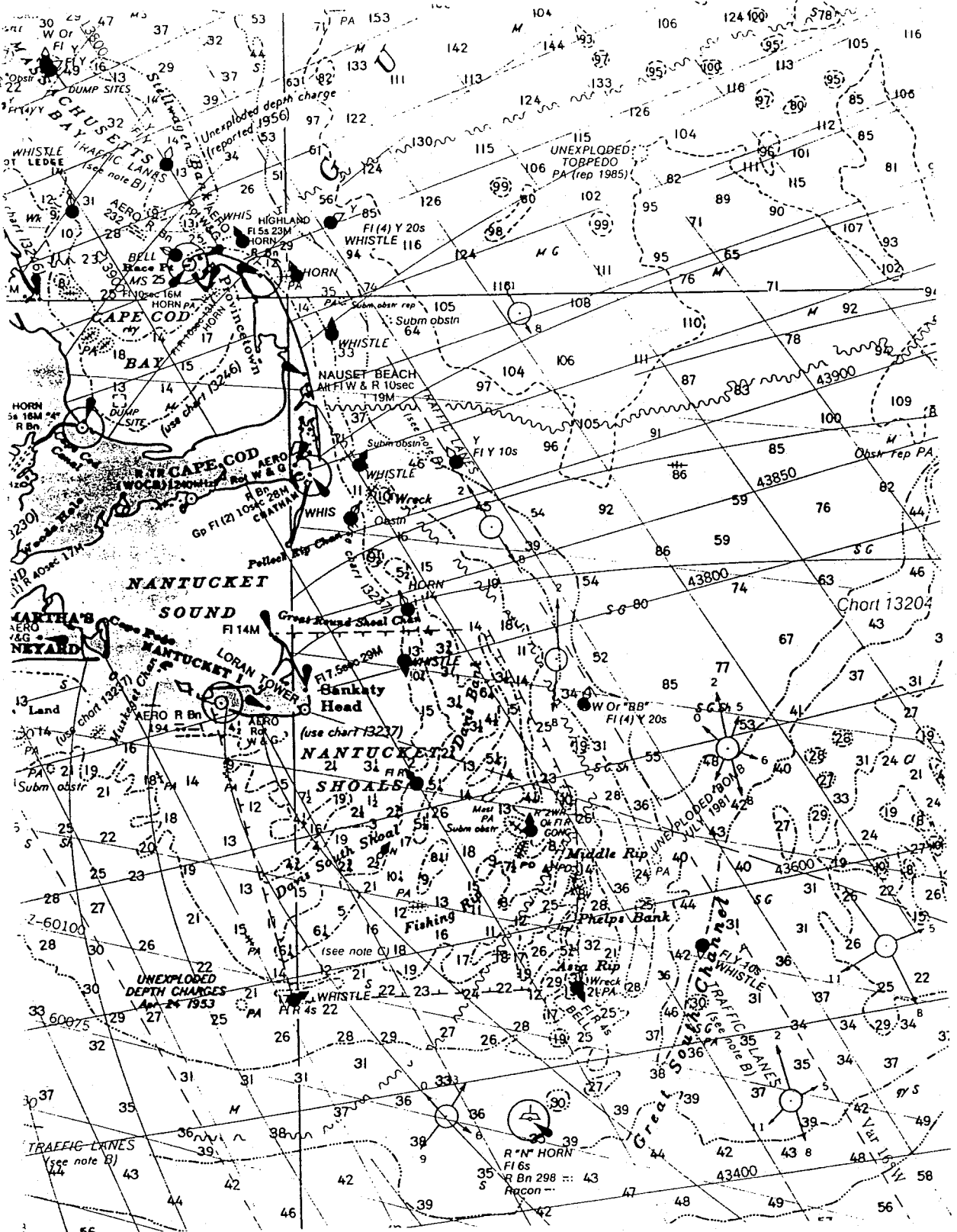

**Table 1.** Temperature record (degrees F) of scallops from chill-tote, bagging and stowage for six 6-hour watches (W<sub>1</sub>-W<sub>6</sub>). Bag-up and stowage temperatures represent internal bag temperatures for one bag of five from each watch. Temperatures were tracked at 6-hour intervals until internal temperatures stabilized and intermittently until after offloading prior to processing. Total stowage time, 7-8 days; seawater temperature 62-65° F.

	W <sub>1</sub>	W <sub>2</sub>	W <sub>3</sub>	W <sub>4</sub>	W <sub>5</sub>	W <sub>6</sub>
Chill-tote	41.6	44.0	44.8	47.6	43.4	44.4
Bag-up	44.2	46.6	49.8	44.8	48.4	46.8
Stowage (hrs)						
6	39.2	36.4	41.2	39.6	37.4	38.8
12	34.8	35.8	36.6	37.0	35.2	37.2
18	34.8	34.6	35.4	35.0	34.6	36.4
24	34.6	34.0	34.6	34.6	35.4	-
30	34.4	34.0	34.6	35.2	-	35.6
36	34.0	34.6	35.4	-	35.4	-
42	34.0	35.2	-	34.6	-	-
48	34.8	-	35.0	-	-	35.6
54	-	35.6	-	-	35.4	-
60	35.2	-	-	34.6	-	35.6
66	-	-	35.2	-	35.4	-
72	-	35.0	-	34.6	-	-
78	35.2	-	35.2	-	-	-
84	-	35.0	-	-	-	-
90	34.6	-	-	-	-	-
Ex-vessel	36.6	36.2	35.6	35.4	36.8	36.0



**Table 2.** Percent moisture and protein (wet weight) of sea scallop meats used for the study to evaluate processed sea scallops. Sea scallops were harvested on September 2-3 during six 6-hour watches ( $w_1$  -  $w_6$ ) off Cape Cod, Massachusetts; seawater temperature 62-65° F, depth 19-24 fathoms. Scallops held in insulated tote with 1:4 ice:seawater mix for three hours prior to bag-up; bag-up temperature 44.2-49.8° F; average meat count 58 meats per pound, 30 bags, approximately 1200 lbs.; stowage time, 7-8 days.

	AT-HARVEST		TOTE		EX-VESSEL	
	Moisture	Protein	Moisture	Protein	Moisture	Protein
$w_1$	76.75	18.79	77.85	17.18	78.43	17.15
$w_2$	76.97	18.82	77.61	17.35	77.93	16.42
$w_3$	77.30	18.52	78.07	17.54	79.56	16.59
$w_4$	77.20	18.81	78.15	17.75		
$w_5$	77.11	18.77	78.89	16.90		
$w_6$	77.37	17.91	78.40	17.28		
Mean	77.11	18.60	78.16	17.33	78.64	16.72
Range	76.75- 77.37	17.91- 18.82	77.61- 78.89	17.18- 17.75	77.93- 79.56	16.42- 17.15
Change			1.06	<1.27>	1.53	<1.88>

**Table 3.** Percent moisture and protein (wet weight) of raw sea scallop meats harvested on August 30-31 over a 36-hour period in the Great South Channel. Seawater temperature 60-62° F, depth 30-49 fathoms. Shellstock harvested off Cape Cod, Massachusetts, on August 27-28 and held on ice until shucking. Scallop meat held in insulated tote with 1:4 ice:seawater mix for three hours prior to bagging. Bag-up temperature 43.5-44.2° F; average meat count 44.2 meats per pound, 30 bags, approximately 1200 lbs.; stowage time, 10-11 days.

	AT-HARVEST		SHELLSTOCK		TOTE		EX-VESSEL	
	Moist.	Prot.	Moist.	Prot.	Moist.	Prot.	Moist.	Prot.
	75.86	17.29	76.49	17.61	77.62	17.50	81.39	14.76
	74.89	18.21	76.48	17.55	78.20	18.43	79.74	15.55
	75.00	18.63	76.17	17.82	75.92	16.99	78.08	16.88
			[ 75.84	[ 17.92	75.16	19.67	79.73	16.22
			75.28*	17.95*	81.90	14.29	79.17	16.55
Mean	75.25	18.04	75.95	17.74	77.76	17.49	79.62	16.09
Range	74.89-	17.29-	75.28-	17.55-	75.16-	14.29-	79.17-	14.76-
	75.86	18.63	76.49	17.95	81.90	19.67	81.39	16.88
Change				2.16	<0.40>	4.02	<1.20>	

\*Duplicate Sample

**Table 4.** Percent moisture and protein (wet weight) of raw sea scallop meats harvested on September 5-6 over seven 6-hour watches in (w<sub>1</sub> - w<sub>7</sub>) the Great South Channel. Seawater temperature 60-63° F, depth 28-40 fathoms. Shellstock harvested off Cape Cod, Massachusetts, on September 3-4 and held on ice until shucking. Scallops held in insulated tote with 1:4 ice:seawater mix for three hours prior to bag-up; bag-up temperature 46.4-53.8° F; average meat count of mixed scallops 42.4 meats per pound, 35 bags, approximately 1400 lbs.; stowage time, 5-7 days.

	AT-HARVEST		SHELLSTOCK		TOTE (MIX)		EX-VESSEL	
	Moist.	Prot.	Moist.	Prot.	Moist.	Prot.	Moist.	Prot.
w <sub>1</sub>	75.92	19.41	75.81	19.26	77.40	18.27	--	--
w <sub>2</sub>	75.85	19.56	76.01	18.56	76.50	17.97	79.78	16.34
w <sub>3</sub>	74.91	19.17	75.57	18.53	77.66	17.80	79.18	16.49
w <sub>4</sub>	75.12	19.88	75.74	18.45	77.60	17.87	79.11	16.13
w <sub>5</sub>	76.32	19.28	76.10	19.20	76.39	17.42	78.30	17.94
w <sub>6</sub>	74.66	19.65	76.12	18.53	77.59	17.04	78.88	16.84
w <sub>7</sub>	[ 76.14 75.66*	17.11	75.41	17.84	76.52	[ 17.64 18.09*	79.32	16.08
Mean	75.58	19.15	75.84	18.62	77.09	17.76	79.09	16.64
Range	74.66- 76.32	17.11- 19.88	75.41- 76.12	17.84- 19.26	76.39- 77.66	17.04- 18.27	78.30- 79.78	16.08- 17.94
Change					1.25	<1.12>	3.38	<2.24>

\*Duplicate Sample

**Table 5.** Percent moisture and protein (wet weight) of sea raw scallop meats harvested on September 9 in the Great South Channel over three 6-hour watches ( $w_1$  -  $w_3$ ). Seawater temperature 65-66° F, depth 38-40 fathoms. Scallops held in insulated tote with 1:4 ice:seawater mix for three hours prior to bag-up. Bag-up temperature 47.8°F, average meat count 43.0 meat per pound, 11 bags, approximately 440 lbs.; stowage time, 1-2 days.

	AT-HARVEST		TOTE		EX-VESSEL	
	Moisture	Protein	Moisture	Protein	Moisture	Protein
$w_1$	77.35	17.85	78.06	17.26	79.27	17.24
$w_2$	76.29	17.39	77.60	17.41	79.01	16.71
$w_3$	75.88	18.06	78.19	16.84	78.98	17.60
Mean	76.50	18.10	77.95	17.17	79.06	17.29
Range	75.88- 77.35	17.39- 18.06	77.60- 78.06	16.84- 17.41	78.98- 79.27	16.71- 17.24
Change			1.45	<0.93>	2.56	<0.81>

## SECTION 2. SAMPLING AND PROCESSING

### Methods

Upon offloading, the 30 bags of scallops used for this study were placed in insulated totes and removed to the processing plant adjacent to the offloading area. Ex-vessel samples of scallop meats were obtained for proximate analyses, nutritional profiles, microbiological evaluation and meat counts (meats per pound, MPP). Twelve of the 30 bags were opened along the side of the bag and approximately one pound of scallops was removed from each. Care was taken to include scallops from both the core and periphery of the bag. A four-ounce portion from each of these samples was retained for nutritional profile analyses. A composite of the remaining scallops from each sample was used to obtain three one-pound subsamples for the proximate analyses.

Scallops for ex-vessel microbiological evaluation were obtained from three of the remaining unopened bags. Scallops were aseptically removed from the bags, placed in sterile Whirl-Pak™ bags and stored in ice for two to four hours. Scallop surface pH was recorded on samples from the same bags. Meat counts, or meat per pound (mpp), were determined from ten of the opened bags.

Six processing methods were evaluated in this study. Five bags or approximately 200 pounds of scallops were used for each processing method. Scallops for this study were processed at a commercial scallop processing facility using standard equipment. The six processing methods evaluated for this study were as follows:

FW Wash - a twenty minute wash in fresh water (pH 7.5) supplied by the local municipality.

STP Wash - a twenty minute wash in a 4.0% STP and 1.0% sodium chloride solution (w/w, pH 8.3).

STP Dip - a twenty minute wash in fresh water followed by a one minute dip in a 10% STP and 1.0% sodium chloride solution (w/w, pH 8.3).

STP Processed - time variable static process in a 2.5% STP and 1.0% sodium chloride solution (w/w, pH 8.3).

All processing solutions were pre-chilled to  $48 \pm 2^{\circ}$  F and a 2:1 solution weight to scallop weight ratio was used in 200-gallon capacity processing totes. A 1.0% sodium chloride (NaCl) solution was used in conjunction with STP to enhance the water binding capacity of the scallop tissue proteins (Fisher et al 1990). Scallops were processed in three 70-pound batches for each processing method listed above thus providing triplication. Processing washes and dips were conducted one at a time. Variable time processing methods (STP Processed) were conducted simultaneously. Scallop moisture content was monitored hourly with four OHAUS MB 200 moisture balances for the first five hours of processing, thereafter every four hours. Scallops within the processing solution were mixed at each of the previously mentioned sampling intervals. Scallop meat surface pH and microbiological evaluations were determined prior to and following each processing method, with duplicate samples of scallops taken for proximate and nutritional analyses. The remaining scallops were weighed into five-pound units, packed in plastic bags, placed in waxed boxes and commercially plate frozen. Scallops were held in a commercial cold storage facility at  $-30^{\circ}$  F. The frozen scallops were used for consumer preference studies and for frozen storage evaluations at 3-, 6-, 9- and 12-month intervals.

#### Analytical Methodology

Microbiological evaluation of scallops was performed by the enumeration of total aerobic bacteria using Petrifilm™ aerobic plates<sup>1</sup>. Sampling was done in triplicate for ex-vessel and for pre- and post-processing end

---

<sup>1</sup>3M Microbiology Products  
St. Paul, Minnesota

points. Five to six scallop meats per sample were aseptically cut in half with one-half of each meat placed in a sterile blender jar. Homogenates were prepared with 25 grams of scallop meat according to AOAC (1990) method 966.23B using Butterfields phosphate-buffered diluent. Each homogenate was serially diluted ( $10^{-3}$  through  $10^{-7}$ ) and plated, in duplicate, on dry-film plates according to Petrifilm™ procedures (1987). Plates were incubated at  $35 \pm 1^\circ$  C for  $48 \pm 3$  hours. Enumerations were made on plates with 30 to 300 colonies per plate and recorded as colony forming units per gram of scallop tissue (cfu/g) and log cfu/g. Statistical analysis of mean differences were conducted by the Bartlett test of homogeneity and the Scheffe test for significance.

Proximate analysis included moisture, protein, ash and total carbon. Triplicate one-pound samples were obtained from pre- and post-processed scallops for all processing methods. Samples were frozen and transported to the VIMS Nutrient Analysis Laboratory. Methodology for moisture and protein determinations are listed in Appendix 4. Mean differences of thawed scallop moisture content was analyzed by the Scheffe test for significance.

Nutrients analyzed for this study are listed in 21 CFR (Code of Federal Regulations, 1990) 101.9(C)(7)(IV) which were determined to be 2 percent or more of the U.S. Recommended Daily Allowance (RDA) as listed in 21 CFR 101.3(E)(4) (1990) and are as follows: protein, vitamin C, riboflavin, niacin, calcium, vitamin B<sub>12</sub>, magnesium, zinc and copper<sup>2</sup>. Phosphorus and sodium were added to the list of nutrients. Nutritional equivalency for each nutrient was determined for both raw and cooked scallops. Nutritional equivalency values for cooked scallops were used as a basis of comparison to values listed in U.S. Department of Agriculture (USDA) Handbook 8-15, Finfish and Shellfish Products (1987). Nutritional profiles were determined on cooked natural, ex-vessel and freshwater and STP-washed scallops. Product sampling for nutrient profile analyses followed procedures listed in 21 CFR 101.9(E), (1) and (2) (1990). Twelve 3- to 4-ounce subsamples (consumer units) were obtained from each processing end point and placed in Whirl-Pac™ plastic bags. A composite of the 12 subsamples constituted a single sample. Consequently, triplicate samples were obtained for each processing end point. Samples for the analysis of cooked scallops were iced and transported

---

<sup>2</sup>This list of nutrients was determined by the FDA prior to the initiation of this study.

to VIMS. Samples for the analysis of raw scallops were packed in five-pound cardboard waxed containers, plate frozen and held in commercial cold storage at -20° F.

The method used to cook the scallops was broiling (Tappan Electric Oven Model #11-4173). Scallops were arranged on a self-draining broiler pan with 3 subsamples of a particular sample (processing method end point) and placed in the oven five inches from the pre-heated electric broiling coil. Scallops were held in the oven, with oven door open one inch, until cooked. Cooked is defined as heating product until an internal temperature of 70° C is reached (AOAC 976.16; 1990). Internal temperatures were monitored using type "K" teflon insulated thermocouples and Omega HH-51 thermal recorder. Cooking time was recorded for each group of scallops. Six subsamples per group (processing method end point) of scallops were weighed prior to and after cooking. After cooking, scallops were allowed to drain and cool for two minutes, placed in Whirl-Pak™ bags, blast frozen and held in commercial cold storage at -20° C. The frozen raw and cooked scallops were transported by air to ABC Research, Gainesville, Florida, for nutrient profile analyses. ABC Research is a FDA, USDA and Environmental Protection Agency (EPA) recognized laboratory (USDA Certification #1276, EPA Certification #E82031). Compositing of subsamples were performed by ABC Research and methods of analyses are listed in Appendix 5.

## **Results and Discussion**

### **Processing**

By design, the processing methods used in this study provided marketable processed sea scallop meats with varying moisture and residual phosphorus levels. Targeted moisture contents for STP Processed scallops of 82, 84, and 86% were not realized due to processing constraints. Scallops with different processing times and resultant moisture content are referenced as STP Processed 81.6% (5 hours), 82.4% (13 hours) and 83.9% (24 hours). Scallop moisture content changes associated with processing are presented in Table 6. Changes in



scallop moisture content and weight of cooked, not previously frozen scallops, are presented in Table 7. Changes in scallop moisture content and weight of frozen/thawed cooked scallops are reported in Table 8. Residual added phosphorus and corresponding phosphate levels resulting from STP processing are given in Table 9. Weight changes associated with freeze/thawing and cooking (Table 8) were obtained by recording weight before and after thawing.

#### Moisture and Weight Change

Moisture content increased with processing time in STP Processed scallops (Table 6). STP Processed (24 hours) resulted in scallops with the highest moisture content (83.9%). STP Wash process resulted in scallops with the lowest moisture content (79.7%). Given the same processing wash times, FW Wash process resulted in scallops with a moisture content of 82.5%, while the moisture content of STP Wash processed scallops was limited to 79.7%. STP Dip process resulted in scallops with a moisture content of 81.3%. The increase in moisture content of STP Dip scallops can be attributed to hydration<sup>3</sup> occurring during the FW Wash period prior to the actual dip process. Previous findings by one of the investigators demonstrate only a minimal increase (0.3-0.7%) in moisture content of unhydrated, shellstocked scallop meats when dipped into a 10% STP solution (Fisher, 1992 unpublished). The difference in moisture content resulting from the STP Dip and FW Wash processing may be the result of water diffusion from the hydrated scallop surface tissue into the hypertonic STP solution (a reverse of tissue hydration observed in FW Wash scallops where scallop tissue was hypertonic to fresh water).

Increasing moisture levels in scallop tissue during processing is largely related to solution contact time. The longer the scallops are held in a fresh water, or a low concentration phosphate solution, the deeper the tissue penetration of the solution, and the more moisture is incorporated. This type of tissue hydration is most likely due to osmotic equilibration and/or phosphate induced protein dissociation and subsequent moisture

---

<sup>3</sup>For this study, hydration is defined as the incorporation of bound and unbound water into scallop adductor muscle.

binding. Important factors controlling moisture uptake include solute concentration, the type of phosphate used and processing time (Fisher, 1992 unpublished). Differences observed in scallop moisture content between STP Wash and FW Wash processes typifies the moisture limiting effect of adding salts (ie. STP and/or NaCl) to processing water. As solute concentrations approach that of scallop tissue, the rate of moisture incorporation into scallop tissue is reduced (Fisher et al. 1990). This is also demonstrated by lower moisture levels observed in STP Processed 5 and 13 hour processes, when compared to the 20 minute FW Wash process (Table 6).

Scallop meat weight increases associated with processing may also be viewed in terms of decreasing meat counts. Meat count decreases are proportional to moisture content increases. Meat counts were observed to decrease from time of harvest through vessel stowage periods and shore-side processing (Table 6).

Moisture loss of cooked, unfrozen processed scallops is shown in Table 7 and is expressed as percent weight loss. STP Dip processed scallops experienced the least amount of drip loss (12.4%), with FW Wash processed scallops having the most (19.0%). Weight loss in STP Processed scallops increased with increasing scallop moisture content and processing time. Weight loss from STP Wash and FW Wash processed scallops demonstrate a primary functional property phosphates provide to meat systems (i.e. increased water binding capacity). The use of 4% STP in a wash resulted in less tissue hydration combined with effective moisture retention (Table 6, 7). FW Wash processed scallops resulted in a greater degree of tissue hydration, with a minimal moisture retention capacity. All processing methods using STP enhanced moisture binding in cooked scallops over unprocessed cooked scallops (Table 7). Cooking times decreased with increasing scallop moisture contents (Table 7). Average cook time was longest for initial unhydrated scallop meats (77.1% moisture) and shortest for STP Processed 24 hour scallops (83.9% moisture). It is reasonable to assume that given equal broiling times, moisture loss will vary depending on scallop moisture content and whether or not phosphates are used.

The moisture loss of processed frozen/thawed scallops is illustrated in Table 8, expressed as percent weight loss. In a direct comparison illustrating the effectiveness of STP in binding moisture, FW Wash processed scallops averaged a 15.03% weight loss upon thawing, while STP Wash processed scallops averaged only a 3.45% loss. Maximum moisture retention of frozen-then-thawed scallops was observed in STP Dip processed scallops

(.94% drip loss), with minimal retention observed for FW Wash processed scallops (15.0% drip loss). The use of freshwater in processing provided little or no moisture binding capacity. Dipping FW Wash processed scallops in a 10% STP solution provided scallops with significant moisture retention properties. However, the resulting moisture content upon thawing was highly variable (Table 8). Thawed moisture content is not directly comparable to dip loss by weight, in part, because soluble proteins, minerals and vitamins are present in drip liquid. Thawed scallop moisture contents showed no significant differences (.05 level) between STP Dip processed and STP Processed 5 hour scallops. However, STP Processed 13 and 24 hour scallops had a significantly (.01 level) higher thawed moisture content than STP Dip scallops. The least effective of the phosphate treatments in binding moisture was observed in STP Processed (81.6%, 5 hrs.) scallops.

Total changes in moisture content, from processing through freeze/thaw and cooking, was calculated (Table 8). STP Dip process and STP Processed 5 and 13 hour processes resulted in scallops with net moisture contents similar to ex-vessel scallops. These three processing methods resulted in similar moisture content increases, but differed in the method of STP application. The 10% STP Dip was as effective in binding moisture as the 2.5% STP solution with a 5 and 13 hour processing times. FW Wash process resulted in the greatest net loss in scallop moisture (3.8%) followed by STP wash (2.1%). STP Processed 13 and 24 hour processes showed a net increase in moisture content of 1.1% and 2.5% respectively. Phosphate effectiveness in binding moisture is again evident in moisture content change between FW Wash processed scallops (-3.8%) and STP Dip processed scallops (-0.7%), where the only difference in processing was a one minute exposure to a 10% STP solution following the FW Wash treatment.

### Phosphate Incorporation

The incorporation of phosphate in scallop meat occurred in all processing methods using STP. Since STP was the phosphorus source used in this study, added percent phosphorus in processed scallops was converted to percent added phosphate as STP (Table 9). The percentage of phosphate in ex-vessel scallops was used as the baseline value to calculate added phosphate values for processed scallops. Phosphate content below the ex-

vessel value was observed in FW Wash processed scallops and is not uncommon in scallop processing using freshwater alone (Fisher, 1992 unpublished). None of the processing methods used in this study resulted in residual phosphate levels of 0.5% (Federal Register, Vol. 44, No. 244, December 1979, Proposed Rules). The highest level of added phosphate was recorded for STP Dip (0.344%), which used the highest concentration of STP. These results indicated that high concentrations of STP interacts with scallop tissue very rapidly.

Because of the short contact time in a dip process, incorporation of phosphate is expected to be limited to tissue surfaces. At lower concentrations of STP in solution, phosphate incorporation into scallop tissue was observed to be relatively slow, with phosphate concentration increasing with contact time (Table 9). Results indicate that STP incorporation at these low solution concentrations rely on moisture transport for tissue incorporation. In review of these results, and in reference to freeze/thaw percent weight loss (Table 8), moisture retention in scallops is shown to increase with increasing levels of added phosphate. These results indicate that regardless of STP application method, functional properties of phosphate are achieved in scallop processing. However, the degree of scallop hydration during phosphate incorporation can differentiate between phosphate application methods.

#### Aerobic Plate Counts

Microbiological evaluation of scallop processing methods, using STP indicated a limited reduction of microbial loads (Table 10). FW Wash process had no effect on scallop bacterial populations. Reductions in the number of bacteria on scallop meat surfaces were observed for all processing methods containing STP and NaCl. However, the degree of bacteria reduction varied between processing methods. The largest reduction of bacteria was observed after the STP Dip process (2.0 log reduction). STP Processed treatments resulted in bacteria reductions with increasing processing time. Log reductions of 1.2, 1.3 and 1.7, were observed for processing times of 5, 13, and 24 hours respectively. Negligible bacteria reduction (0.1 log) occurred as the result of STP Wash processing. The reasons for the variation in microbial reductions between processing methods using STP can only be speculated. Results indicated that pH shifts to a more alkaline environment during processing may

reduce the bacteria load on scallop meat surfaces. However, bacteria reduction was not proportional to observed shifts in pH. A high phosphate concentration was observed to significantly reduce scallop bacteria during processing. A one minute dip in a 10% STP solution resulted in a 2.0 log reduction while a 20 minute wash in a 4% STP solution only resulted in a 0.1 log reduction.

These microbial reductions on the scallops could be explained by phosphate interactions with scallop proteins. Alkaline phosphates increase solubility of salt-soluble muscle protein (Molins, 1991), and Sofos (1986) reported on the ability of phosphates to sequester cations, which can inhibit bacterial cell growth. Short processing periods (STP Wash) may not allow for bacterial inhibition through sequestration to occur. The presence of NaCl in the STP solutions may also contribute to anti-microbial activity. Interactions of polyphosphates with NaCl have been reported to demonstrate anti-microbial properties in processed meat products (Sofos, 1986).

Pair-wise comparison probabilities of the mean log changes in bacterial counts resulting from processing further demonstrate possible STP anti-microbial capacity. Significant differences at the .05 level were observed between FW Wash and STP Processed (24 hour) scallop processing, and between STP Wash and STP Processed (24 hour) processing methods. Differences at the .01 significance level were observed between FW Wash and STP Dip processing, and between STP Wash and STP Dip processing.

#### Nutritional Equivalency

Nutritional equivalency data results are presented in Table 11 for raw scallops and in Table 13 for cooked scallops. Nutrient values listed are per 100 gram portions (3.5 oz). Nutritional profiles for labeling purposes are based on 3 oz. portions of cooked product (Federal Register, 1992). Therefore, nutrient analysis of raw product will only be discussed here to illustrate changes in nutrient equivalency as a result of moisture loss and nutrient degradation from heat associated with cooking (Table 13). Nutrient equivalency results were converted to percent U.S. RDA values as shown in Table 14.

Nutrient levels in scallops are largely affected by changes in moisture content. Moisture increases and moisture retention are important concerns when evaluating nutritional equivalency of processed scallops. Moisture hydration during vessel stowage and shore-side processing increased scallop weight. As moisture is added, nutrient components are generally reduced on a per weight basis. It is assumed added water is free of soluble nutrients which can be incorporated into scallop muscle (Table 11). This inverse relationship is most noticeable in protein, but is observed to a lesser degree for other nutrients. Increases in phosphorus and sodium are the result of processing with STP.

Moisture addition to scallop meat creates a nutrient dilution effect. Moisture loss has a concentrating affect on certain nutrients while water soluble nutrients are lost with moisture loss. Moisture loss from scallops due to freeze/thawing and/or cooking provided variable results for individual groups of nutrients within the profiles. With the loss of moisture, weight decreases, thereby concentrating macronutrients and many minerals. Nutrient values for protein, calcium, magnesium, zinc and copper were observed to increase upon cooking of ex-vessel scallops which had experienced some hydration from vessel stowage but were not further processed (Table 13). However, as moisture is removed from these scallops, water-soluble vitamins are also removed. Riboflavin, niacin, and B<sub>12</sub> were observed to decrease upon cooking ex-vessel unprocessed scallops (Table 13). As previously mentioned, the use of STP in a wash process provided a lesser degree of hydration while increasing scallop moisture binding capacity when compared to the FW Wash process. Moisture loss during cooking of STP Wash processed scallops was reduced, thereby reducing loss of water soluble vitamins.

Comparative differences between cooked scallop nutrients varied with phosphate use and moisture content resulting from the various processing methods used for this study. Increased scallop moisture resulted in decreased scallop protein (Table 12). Water-soluble vitamins B<sub>12</sub>, riboflavin, and niacin were also observed to be greatly affected by moisture content. Scallops with higher cooked moisture contents generally contained less water-soluble nutrients. Although some nutrients (mainly water-soluble nutrients) are removed in cook drip liquid, other nutrients (protein and minerals) may increase proportional to moisture loss. Phosphate use in scallop processing reduced nutrient loss in cooked product by reducing drip loss. STP Wash processed cooked scallops retained more nutrients than FW Wash processed cooked scallops (Table 12). Differences in the protein

between both wash processing methods were negligible in cooked scallops even though hydration was more extensive for FW Wash processed scallops. Of the processing methods evaluated for this study, STP Dip process was generally most successful in retaining soluble vitamins and macrominerals.

Phosphorus and sodium contents were elevated for all processed scallops using STP (Table 12) and were associated with STP concentration and processing time. High concentrations of STP in solution resulted in rapid phosphorus and sodium incorporation (STP Dip, Table 12). At lower concentrations, these macrominerals are incorporated more slowly over time (STP Processing, 5, 13, 24 hours, Table 12).

Nutrient profiles expressed as percent U.S. RDA are presented in Table 14. Changes in nutrient percentages reflect changes observed in raw and cooked nutrient profiles (Tables 11, 12, 13). Nutrient percentages varied in relation to increases in moisture content and incorporated phosphate are previously discussed. Vitamin C, calcium, and copper were determined to be less than 2% U.S. RDA for all processed and unprocessed scallops. Vitamin C and calcium values observed in this study were lower than the 3% and 2% U.S. RDA values, respectfully, used by FDA as guidelines for voluntary labeling of scallops (Federal Register, 1992). The scallop protein level of 29 grams per three ounce serving used for the FDA guideline is also quite different from the scallop protein levels observed in this study. Scallop protein levels determined in this study per three ounce serving size (protein levels calculated by converting grams of protein per 100 g, as listed in Table 12, to grams per 85 grams (3 oz.)) ranged from 10.7 grams (STP Processed 24 hrs.) to 16.9 grams (Initial). Percent U.S. RDA values reported in this study (Table 14) would be rounded-off for nutritional labeling declaration purposes. For labeling, percentages must be expressed in 2% increments up to and including the 10% level, and in 5% increments above 10% levels and up to and including the 50% level (21 CFR 101.9 (c)(7)(i) 4-1-90).

## Conclusions

### Processing

Processing sea scallops in freshwater resulted in rapid moisture addition, minimal moisture retention capacity and had no effect on scallop bacteria counts. The use of STP in processing sea scallops reduced the rate of moisture incorporation, enhanced scallop moisture binding capacity and maintained a degree of antimicrobial capacity. Scallop moisture content increased with processing time. Short processing times using a higher concentrated STP solution performed as well, or better, in binding moisture than longer processing times using a lower concentrated STP solution. The more phosphate incorporated into the scallop meat, the greater the moisture binding capacity. Drip loss associated with frozen/thawed and cooked scallops was minimized in STP Dip processed scallops, which also had the largest amount of incorporated phosphate. The largest reduction of bacteria during processing occurred using a high concentrated STP solution as a dip. Bacteria reductions were also observed to increase with processing time using a lower concentrated STP solution (STP Processed).

### Nutritional Equivalency

Sea scallop nutritional components are largely affected by changes in moisture content. Increasing moisture content decreases nutrient levels. Nutrients, most effected by increasing moisture content are protein, niacin, calcium, and vitamin B<sub>12</sub>. Moisture loss due to freeze/thaw or cooking concentrated some nutrients (protein and minerals), while contributing to the loss of water-soluble nutrients. The use of STP reduced scallop drip loss, which in turn, reduced nutrient loss.



**Table 6.** Moisture content (MC), and meat count (MPP) changes associated with unprocessed and processed fresh sea scallops.

	Initial MC (n=3)		Processed MC (n=3)		Meat Count (MPP)* n=6
	$\bar{x}$	Range	$\bar{x}$	Range	
Initial	77.1	76.7-77.4	--	--	61.7
Ex-vessel	78.6	77.9-79.5	--	--	57.3
Wash (20 min.)					
Freshwater	--	--	82.5	82.1-83.2	51.0
STP (4%)	--	--	79.7	79.6-79.8	53.0
STP Dip (1 min., 10%)	--	--	81.3	80.6-81.9	51.6
STP Processed (2.5%)					
81.6 (5 hrs.)	--	--	81.6	80.8-82.7	50.0
82.4 (13 hrs.)	--	--	82.4	81.3-83.5	49.2
83.9 (24 hrs.)	--	--	83.9	83.5-84.3	43.2

\*Average number of scallop meats per one pound.

**Table 7. Percent weight (WT) and moisture content (MC) changes of cooked unprocessed and processed fresh sea scallops.**

	Cooked MC (n=3)		Cooked WT loss (n=9)		Avg. Cook Time (min:sec) n=6	Total Avg. MC Change
	$\bar{x}$	Range	$\bar{x}$	Range		
Initial	75.7	74.9-76.5	10.5	9.8-11.5	4:25	<2.1>
Ex-vessel	77.0	76.9-77.1	16.7	15.5-18.2	4:13	<1.6>
Wash (20 min.)						
Freshwater	79.0	78.0-80.6	19.0	16.8-21.3	3:55	0.4
STP (4%)	77.6	77.1-78.3	13.1	11.8-15.8	4:03	<1.0>
STP Dip (1 min., 10%)	79.3	78.8-79.6	12.4	10.7-13.3	3:48	0.7
STP Processed (2.5%)						
81.6 (5 hrs.)	80.2	79.9-80.6	14.1	13.3-17.3	3:40	1.6
82.4 (13 hrs.)	81.2	81.1-81.6	14.6	13.1-16.6	3:45	2.6
83.9 (24 hrs.)	81.3	80.6-82.3	15.1	14.0-16.1	3:25	2.7

**Table 8.** Average percent changes in weight (WT) and resulting moisture content (MC) of frozen/thawed then cooked processed\* sea scallops.

	Freeze/thaw	Thaw		Cooked WT	Cooked		Total Change**
	WT loss n=3	MC n=6		loss n=9	MC n=3		MC n=3
	$\bar{x}$	$\bar{x}$	Range	$\bar{x}$	$\bar{x}$	Range	$\bar{x}$
Wash (20 min.)							
Freshwater	15.03	79.5	79.0-79.9	18.40	75.6	74.8-76.1	<3.8>
STP (4%)	3.45	80.1	79.5-80.6	16.57	76.9	76.1-77.2	<2.1>
STP Dip							
(1 min.,10% STP)	0.94	81.0	80.6-86.3	12.02	78.0	77.7-78.4	<0.7>
STP Processed							
(2.5% STP)							
81.6 (5 hrs.)	7.48	80.9	80.6-81.2	18.49	77.7	77.2-78.3	<1.1>
82.4 (13 hrs.)	6.75	83.4	82.6-83.8	18.88	79.5	79.4-79.7	1.1
83.9 (24 hrs.)	5.91	84.3	83.6-84.6	17.98	80.6	80.0-81.2	2.5

\*1% NaCl was added to all STP containing processing solutions.

\*\*Change in moisture content is relative to ex-vessel average moisture content of 78.6 percent.

**Table 9.** Average added percent phosphate levels (n=3) in sea scallops resulting from various processes using sodium tripolyphosphate (STP).

	<u>Initial</u>	<u>Ex- vessel</u>	<u>Wash</u>		<u>STP Dip**</u>	<u>STP Process***</u>		
			<u>FW</u>	<u>STP*</u>		<u>81.6</u>	<u>82.4</u>	<u>83.9</u>
Phosphorus (P)	.286	.280	.223	.306	.368	.302	.312	.318
Phosphate (P <sub>2</sub> O <sub>5</sub> )	.646	.633	.504	.691	.832	.682	.705	.719
Added P <sub>2</sub> O <sub>5</sub> from ex-vessel	NA	----	<.129>	.058	.199	.049	.072	.086
Added phosphate as STP	NA	----	<.223>	.100	.344	.085	.124	.149

\* 4% Sodium tripolyphosphate + 1% NaCl solution.

\*\* 20 minute wash with freshwater followed by a 1 minute dip into a 10% sodium tripolyphosphate + 1% NaCl solution.

\*\*\* 2.5% sodium tripolyphosphate + 1% NaCl solution. Processing times: 81.6 = 5 hours, 82.4 = 13 hours, and 83.9 = 24 hours.

**Table 10.** Aerobic plate counts for various processing procedures with and without the use of sodium tripolyphosphate (STP)\*.

Sample ID	Average TPC (n=3)						
	Before processing			After processing			
	Meat pH	cfu/g	log	Meat pH	cfu/g	log	$\Delta$ log
Ex-vessel	5.8	$1.7 \times 10^7$	7.23	----	----	----	----
Wash:							
Freshwater	5.8	$3.2 \times 10^7$	7.5	6.4	$2.9 \times 10^7$	7.5	0.0
STP (4%)	5.8	$3.9 \times 10^5$	5.6	7.6	$3.6 \times 10^5$	5.5	0.1
STP Dip (10%)	5.8	$3.2 \times 10^7$	7.5	8.4	$3.5 \times 10^5$	5.5	2.0
STP Processed (2.5%)							
*81.6 (n=3, 5 hr.)	5.8	$2.3 \times 10^6$	6.4	7.3	$1.7 \times 10^5$	5.2	1.2
82.4 (n=3, 13 hr.)	5.8	$2.3 \times 10^6$	6.4	7.9	$1.4 \times 10^5$	5.1	1.3
*83.9 (n=3, 24 hr.)	5.8	$2.3 \times 10^6$	6.4	7.4	$5.5 \times 10^4$	4.7	1.7

\*All STP solutions tested contained a 1% NaCl concentration by weight.

**Table 11.** Average nutritional components (n=3)<sup>+</sup> of unprocessed and processed raw sea scallops.

	<u>Initial</u>	<u>Ex-vessel</u>	<u>Wash (20 Min.)</u>	
			<u>FW</u>	<u>STP*</u>
Moisture (%)	77.8	78.6	82.5	79.7
Protein (%)	17.6	16.7	13.2	16.0
Phosphorus (mg/100g)	277	230	209	277
Riboflavin (B <sub>2</sub> ) (mg/100g)	.067	.062	.065	.055
Niacin (mg/100g)	1.54	1.63	1.38	1.17
B <sub>12</sub> (mcs/100g)	.267	.345	.299	.245
Vitamin C (mg/100g)	<1.0	<1.0	<1.0	<1.0
Sodium (mg/100g)	207	173	143	287
Calcium (mg/100g)	11.00	9.50	9.66	8.03
Magnesium (mg/100g)	47.0	40.6	34.0	35.3
Zinc (mg/100g)	1.2	1.2	1.1	1.1
Copper (mg/100g)	.03	<.023	.026	<.026

\* 4% Sodium tripolyphosphate plus 1% NaCl solution.

<sup>+</sup> Each observation (n) consisted of a composite from 12 subsamples.

**Table 12.** Average (n=3)<sup>†</sup> nutritional components of processed and unprocessed cooked sea scallops.

Nutrient	Initial	Ex-Vessel	Wash (20 min.)		STP DIP**	STP Processing***		
			FW	STP*		81.6	82.4	83.9
Moisture (%)	75.7	77.0	79.0	77.6	79.3	80.2	81.2	81.3
Protein (%)	19.9	18.9	17.7	17.4	16.2	16.0	14.3	12.6
Phosphorus (mg/100 g)	286	280	223	306	368	302	312	318
Riboflavin (mg/100 g)	.062	.044	.048	.058	.058	.064	.060	.059
Niacin (mg/100g)	1.49	1.43	1.49	1.39	1.25	1.07	.99	.91
B <sub>12</sub> (mcg/100 g)	.311	.321	.225	.253	.292	.273	.250	.249
Vitamin C (mg/100 g)	<1.0	<1.0	<1.0	<1.0	<1.0	<1.0	<1.0	<1.0
Sodium (mg/100 g)	223	197	140	310	380	360	446	480
Calcium (mg/100 g)	10.66	10.66	8.43	9.47	9.66	8.16	6.83	6.70
Magnesium (mg/100 g)	50.0	43.3	36.0	40.6	37.0	34.3	30.3	26.3
Zinc (mg/100 g)	1.36	1.43	1.26	1.36	1.20	1.16	1.06	.993
Copper (mg/100 g)	<.023	<.03	.033	.033	<.02	<.023	<.026	<.03

\* 4% Sodium tripolyphosphate plus 1% NaCl solution.

\*\* 20 minute wash with freshwater followed by a 1 minute dip into a 10% sodium tripolyphosphate +1% NaCl solution.

\*\*\* 2.5% sodium tripolyphosphate plus 1% NaCl solution. Processing times: 81.6 = 5 hours, 82.4 = 13 hours, and 83.9 = 24 hours.

<sup>†</sup> Each observation (n) consisted of a composite from 12 subsamples.

**Table 13.** Average (n=3)<sup>+</sup> percent change in nutritional components of unprocessed and processed sea scallops as a result of cooking.

	<u>Initial</u>	<u>Ex-vessel</u>	<u>Wash (20 min.)</u>	
			<u>Freshwater</u>	<u>STP*</u>
Moisture	<2.6>	<2.0>	<4.2>	<2.6>
Protein	13.05	13.2	34.1	8.8
Phosphorus	3.2	22.2	<18.9>	11.8
Riboflavin	<7.4>	<29.0>	<26.1>	5.4
Niacin	<3.2>	<13.2>	8.0	18.0
B <sub>12</sub>	16.4	<6.9>	<24.7>	3.3
Vitamin C	<1.0	<1.0	<1.0	<1.0
Sodium	7.7	13.8	<2.1>	8.0
Calcium	<28.9>	12.2	<12.7>	17.9
Magnesium	6.3	6.6	5.9	15.0
Zinc	13.3	16.7	14.5	23.6
Copper	<<23.3>	<30.4	26.9	<26.9

\* 4% Sodium Tripolyphosphate (STP) + 1% NaCl by weight.

<sup>+</sup> Each observation (n) consisted of a composite from 12 subsamples.



**Table 14.** Average (n=3)<sup>†</sup> Percent U.S. Recommended Daily Allowances per 3 oz. portion of unprocessed and processed cooked sea scallops.

<u>Nutrient</u>	<u>Initial</u>	<u>Ex-vessel</u>	<u>Wash (20 min.)</u>		<u>STP Dip**</u>	<u>STP Processed***</u>		
			<u>FW</u>	<u>STP*</u>		<u>81.6</u>	<u>82.4</u>	<u>83.9</u>
Protein	37.6	35.7	33.4	32.9	30.6	30.2	27.0	23.8
Phosphorus	24.3	23.8	18.9	26.0	31.3	25.7	26.5	27.0
Riboflavin	3.1	2.2	2.4	2.9	2.9	3.2	3.0	2.9
Niacin	6.3	6.1	6.3	5.9	5.3	4.5	4.2	3.9
B <sub>12</sub>	4.4	4.5	3.2	3.6	4.1	3.9	3.5	3.5
Vitamin C	<1.0	<1.0	<1.0	<1.0	<1.0	<1.0	<1.0	<1.0
Calcium	0.9	0.9	0.7	0.8	0.8	0.7	0.6	0.5
Magnesium	10.6	9.2	7.6	8.6	7.8	7.3	6.4	5.6
Zinc	7.7	8.1	7.1	7.7	6.8	6.6	6.0	5.6
Copper	<1.0	<1.3	1.4	1.4	<0.8	<1.0	<1.1	<1.3

\* 4% Sodium tripolyphosphate plus 1% NaCl solution.

\*\* 20 minute wash with freshwater followed by a 1 minute dip into a 10% sodium tripolyphosphate + 1% NaCl solution.

\*\*\* 2.5% sodium tripolyphosphate plus 1% NaCl solution. Processing times: 81.6 = 5 hours, 82.4 = 13 hours, and 83.9 = 24 hours.

<sup>†</sup> Each observation (n) consisted of a composite from 12 subsamples.

### SECTION 3. ICED STORAGE STUDY

#### Objectives

The purpose of this portion of the study was to evaluate the effect of the previously described wash and phosphate application treatments on scallop quality parameters and moisture retention during iced storage. Alkaline polyphosphates are most frequently used in seafood and meat systems to improve water binding, texture and other functional properties. However, shelflife extension is a benefit occasionally attributed to their use (Vyncke, 1978, Spencer and Smith, 1962). This effect may be primarily related to metal ion chelation. Molins (1991) reported that tripolyphosphates form complexes with alkali and earth metals which are more stable than those formed by pyrophosphates which, in turn, are more stable than those formed by orthophosphates.

In a previous study at VPI & SU, scallops held in 3% and 5% solutions of sodium tripolyphosphate for 20 hours maintained higher sensory quality during subsequent iced storage than did either scallops similarly held in water prior to storage or an unprocessed control (Rippen et al, 1990; Appendix 6). The long-term frozen storage stability of sea scallops processed as described in this current study is in progress and will be reported as an addendum when completed.

#### Methods

Scallops treated as previously described (each treatment variable and washed control) were packed into one pound plastic containers immediately following processing using sanitary procedures. They were labeled, packed in ice and transported the same day to the Virginia Tech Seafood Extension and Research Station in Hampton, Virginia. They were held in ice until evaluated.

The treatments referenced in this section are identified by the following designations:

**FW Wash** = scallops washed 20 minutes in fresh water

**STP Wash** = scallops washed 20 minutes in a solution of 4% sodium tripolyphosphate + 1% NaCl

**STP Dip** = scallops washed 20 minutes in fresh water and dipped for 1 minute in a 10% solution of sodium tripolyphosphate + 1% NaCl

**STP Processed (S82, S84 and S86)** = scallops exposed to a solution of 2.5% sodium tripolyphosphate + 1% NaCl for sufficient time to approximately achieve moisture content targets of 82%, 84% and 86%, respectively, and previously referenced as S82 = 81.6%, S84 = 82.4% and S86 = 83.9%.

## Procedures

On days 1, 4, 6, 8, 11, 15, 18 and 20, containers of each treatment (including the wash control) were removed from ice for triplicate analysis (three containers sampled per analysis) for aerobic plate count (APC), moisture and pH. Percents of drip loss and cook loss were determined on days 1, 4, 6, 8, 11 and 15, also in triplicate. An exception was the STP Processed 24 hour (S86) treatment which was not available for evaluation on day 1.

Aerobic (psychrotrophic) plate counts were determined by standard AOAC methods. Twenty-five gram scallop composites were removed aseptically from each container immediately after they were opened. They were diluted 1:10 with 0.1 percent peptone and macerated by stomaching. Subsequent dilutions were made in Butterfield phosphate buffer. One ml portions of appropriate dilutes were plated on Petrifilm APC plates (3M) in duplicate. Plates were incubated at 20°C for 72 hours. Colonies from appropriate plates were enumerated, and results reported as colony forming units per gram (cfu/g).

Moisture was determined by the AOAC oven dry method. Duplicate subsamples (of each replicate) were accurately weighed, dried at 100°C to constant weight (approximately 16 hours) and results reported as percent moisture by weight. Additionally, pH was measured directly from the opened containers with a standardized Orion pH meter and probe.

Containers of scallops were opened, weighed, spread on a sieve, drained for one minute and reweighed. Results were reported as percent drip loss, by weight. Cook losses were determined by accurately weighing (approximately 300g) scallops, broiling them under an electric coil to an internal temperature of 70±2°C (approximately 6½ minutes), allowing them to cool for one to two minutes, then draining and reweighing. Internal scallop temperatures were monitored with a multichannel datalogger (Science Electronics, calibration traceable to a NIST standard) equipped with nude-end copper-constantan thermocouples.

#### Sensory Panel Procedures

On days 4, 6, 8, 11, 15, 18 and 20, each treatment and control were presented to sensory panelists trained in scallop evaluation. From the 15 prospective panelists, ten were selected based on their commitment and procedural comprehension or acuity. Scallops were evaluated raw for appearance and odor, and cooked for appearance, odor, flavor and texture. Unstructured linear scales, anchored by the terms "fresh" and "not fresh" were used for evaluating each of these parameters (Appendix 7). The purpose here was to simultaneously assess all of the various attributes for each parameter which affect the perceived degree of freshness. This differs from descriptive analysis procedures employing specific category scales, (for example, degree of rubberiness as a texture measure). Since no single descriptive term may fully correlate with freshness or shelf-life, training centered on familiarizing panelists with characteristics indicative of fresh (eg. recently harvested) scallops, those that are not at all fresh (ie. spoiled) and those in between.

Panelists were informed of freshness descriptors commonly used for scallops, such as degree of staleness, bitterness, and off-odors and off-flavors (CFR, 1986). They evaluated scallops of various stages of freshness, compared results and were encouraged to discuss other terms and phrases which describe relative freshness.

This process established a common basis for evaluation, however, the descriptors were used only for training. Panelists were instructed that samples should be evaluated independently and that preference or degree of liking (hedonics) was not a test criterion: only degree of freshness.

Recognized sensory panel procedures were followed, including random number generation of sample codes, mixed order of sample presentation, proper lighting and other environmental factors, panel station set-up and care to avoid controllable biases (Meilgaard et al., 1991, Larmond, 1977). The order of sample parameter evaluation was: raw appearance, raw odor, cooked appearance, cooked odor, cooked flavor and cooked texture. That is, all samples were evaluated first for raw appearance, secondly for raw odor, and so on. Cooked scallops were held in covered glass containers in a moist heat environment prior to serving to panelists (usually within ten minutes). They were evaluated warm.

#### Statistical Analysis

Raw data were analyzed by Analysis of Variance (ANOVA) and, where indicated, means compared by Duncan's multiple range procedure ( $\alpha = .05$ ).

### Results and Discussion

#### Moisture

Moisture contents on day 4, the first day that all treatments were available, ranged from 80.4 percent for the STP Wash process to 85 percent for the STP Processed 24 hour (S86) process. The intended targets of 82, 84 and 86 percent moisture contents for the STP Processed treatments were not achieved initially. However, moisture determinations varied during storage and values close to these targets were realized on day 11, Figure

3. Use of sodium tripolyphosphate in STP Wash and STP Dip treatments did not increase moisture levels compared to the FW Wash.

## pH

Phosphate treatments generally raised scallop pH as expected (Wagner, 1986) compared to the FW Wash, with overall reductions in pH during storage (Figure 4). Production of acidic microbial metabolites is likely to be the primary cause of acidification. The release of bases is also expected due to deamination processes. Consequently, the pH values indicate the net release and decomposition of acids and bases in a buffered system; not the specific mechanisms involved. Scallop pH may have some value in quality assessment when processing methods are known.

## Aerobic Plate Counts

Aerobic plate counts (APC) were quite low and generally did not change during storage (Figure 5). Shifts in predominant microflora are possible during this time, however, microbiological populations were not characterized in the study. On days 4, 15 and 18 the STP Dip treatment APCs were significantly lower than FW Wash APCs.

Maxwell-Miller et al. (1982) reported an APC of 7.35 log cfu/g after scallops were held on ice for 14 days. Lower values were reported by Power et al. (1964): 5.7 log cfu/g after 18 days on ice beginning with high quality scallops. The microflora was predominately *Pseudomonas* spp. in that study. This compares to APCs of 4.5 (STP Dip) to 5.5 (FW Wash) log cfu/g for treatments in this study after 18 days of storage. The psychrotrophic incubation procedure used in this study usually produces plate counts higher than those expected from standard APC (35°C) procedures. Mukerji (1992) obtained psychrotrophic plate counts of 2.7 to 5.2 log cfu/g for sea scallops cryogenically frozen at sea, and 5 to 6.2 log cfu/g for fresh sea scallops at off-loading.

Anti-microbial properties of polyphosphates have been previously reported, primarily in poultry (Elliot et al., 1964; Firstenberg-Eden et al., 1981; Foster and Mead, 1976; Steinhauer and Banwart, 1964). Vyncke (1978) attributed observed shelflife extension of ray meat treated with sodium tripolyphosphate to urease inhibition but not to control of microbial growth.

#### Drip Loss

The release of free liquid increased during iced storage, with amount of drip and time of release dependant on treatment (Figure 6). The FW Wash scallops exhibited significantly greater drip losses than the phosphate treated scallops, with most of this loss occurring during the first four days of storage. The STP Processed 24 hour (S86) treatment was significantly less effective at retaining liquid than were the other phosphate treatments. This was probably due to a moisture content in these scallops greater than the water binding capacity of the tripolyphosphate. The least drip loss was achieved by the STP Dip treatment, with visible weepage occurring only on days 11 and 15. Partial protein denaturation and concomitant loss of water holding capacity during storage was expected, and probably accounts for the overall trends. In a previous study, scallops exposed for two hours to a two percent sodium tripolyphosphate solution experienced no net weight change after subsequent freezing and thawing compared to pretreatment weight (Rippen et al, 1990).

#### Cook Loss

As with drip loss, cooking losses increased over time (Figure 7). The STP Dip treatment lost significantly less weight than that of the FW Wash treatment when cooked during the first six days of iced storage. Most of the apparent differences in cook losses between FW Wash and the other phosphate treatments were not significant, except for STP Processed 3 hour (S84) on day 4 and STP Processed 24 hour (S86) on day 11 when less cook loss was recorded for these treatments.

Water may be bound or unbound to various degrees within muscle tissue, and the conditions for its release dependant on changes in protein conformation brought about by chemical, enzymatic and physical effects, including heat induced coagulation. The combined percent weight losses associated with iced storage and cooking are shown in Figure 8. Phosphate treatments generally resulted in less total shrinkage than the FW Wash, with STP Dip producing the least loss of all treatments on days 4 and 6,  $p < .05$ . Treatments producing significantly less loss than the FW Wash were: STP Wash on days 4, 6 and 8; STP Dip on days 1, 4, 6, 8 and 11; STP Processed 5 hour (S82) on days 1, 4 and 6; STP Processed 13 hour (S84) on days 4 and 8; and STP Processed 24 hour (S86) on days 6, 8 and 11.

The increased water binding properties of meat systems containing phosphates has been well documented (Young et al., 1992, 1986; Regenstein and Stamm, 1979; Shults et al., 1972).

#### Sensory Analysis

Appearance and odor scores of raw scallops during iced storage are summarized in Figures 9 and 10, respectively. On day 4, FW Wash was judged to have an appearance that was significantly more fresh than STP Processed 24 hour (S86) and STP Processed 13 hour (S84) appearance. Odors of FW Wash, STP Processed 5 hour (S82) and STP Processed 13 hour (S84) were judged to be significantly more fresh than STP Wash odor on day 4. No significant differences were identified during the remainder of the storage period.

Cooked sensory scores are summarized in Figures 11, 12, 13 and 14. Cooked appearance of the FW Wash was judged to be significantly less fresh than STP Processed 13 hour (S84), STP Processed 5 hour (S82), STP Dip, and STP Wash on day 6, and less fresh than STP Dip, STP Processed 24 hour (S86), STP Processed 5 hour (S82) and STP Wash on day 15 (Figure 11). These results are a partial reversal from raw appearance scores. When raw, the appearance of FW Wash scallops is relatively indicative of fresh scallops but, when cooked, they may appear less fresh than phosphate-treated scallops.

Cooked odor, flavor and texture scores were similar over time, with no significant differences until day 20 when FW Wash and STP Dip scallops rated odor, flavor and texture scores that were significantly more fresh



than STP Processed 24 hour (S86) scallops. The STP Processed 5 hour (S82) cooked texture was also significantly more fresh than STP Processed 24 hour (S86) scallop texture on day 20.

In a previous study, scallop sensory quality was maintained longer during iced storage by use of sodium tripolyphosphate (Rippen et al, 1990, Appendix 6). In that study, higher APCs were encountered and phosphate extended shelflife up to four days. Poultry meat held in three percent polyphosphate overnight produced products that were judged to be lighter in color, more tender and less off-flavored than products presoaked in water or two percent sodium chloride only (Lyon and Magee, 1984).

Long shelflife is a known characteristic of properly handled sea scallops. As previously noted, APCs did not increase appreciably during iced storage. However, during preparation of sensory panel sessions, researchers observed that scallop odor intensity and, to a lesser extent, flavor intensity diminished rapidly after containers were opened and the scallops prepared. This also is a recognized characteristic of scallops which should be considered when interpreting sensory data. The effect may account, in part, for the very long apparent shelflife of scallops used in this study.

### Conclusions

The 80 percent moisture content interim target may not be routinely achievable in properly handled scallops since water contact occurs during chilling, iced storage and washing procedures. The lowest initial mean moisture value determined in this portion of the study was 81.0 percent for the STP Wash treatment. The 10 percent STP Dip treatment generally produced the least drip and cook losses and lowest aerobic plate counts during iced storage compared to FW Wash scallops.

Sensory shelflife was long for all treatments. Few significant sensory differences were identified among treatments during most of the storage period. The appearance of raw FW Wash scallops was initially perceived to be more like fresh scallops than were the high moisture phosphate-treated scallops (STP Processed 13 hour and STP Processed 24 hour), although these differences disappeared during storage. The appearance of cooked

FW Wash scallops was perceived to be less like fresh scallops than were phosphate-treated scallops, except for the highest moisture phosphate treatment (STP Processed 24 hour S86), which was not significantly different.

From this study, the use of sodium tripolyphosphate on fresh scallops appears to have most value in controlling drip losses, cook losses and aerobic plate counts. These benefits were achieved with STP treatments using modest exposure times (less than or equal to 13 hours), generally without exceeding 84% moisture in scallops.

# Figure 3. Scallop Moisture Content During Iced Storage

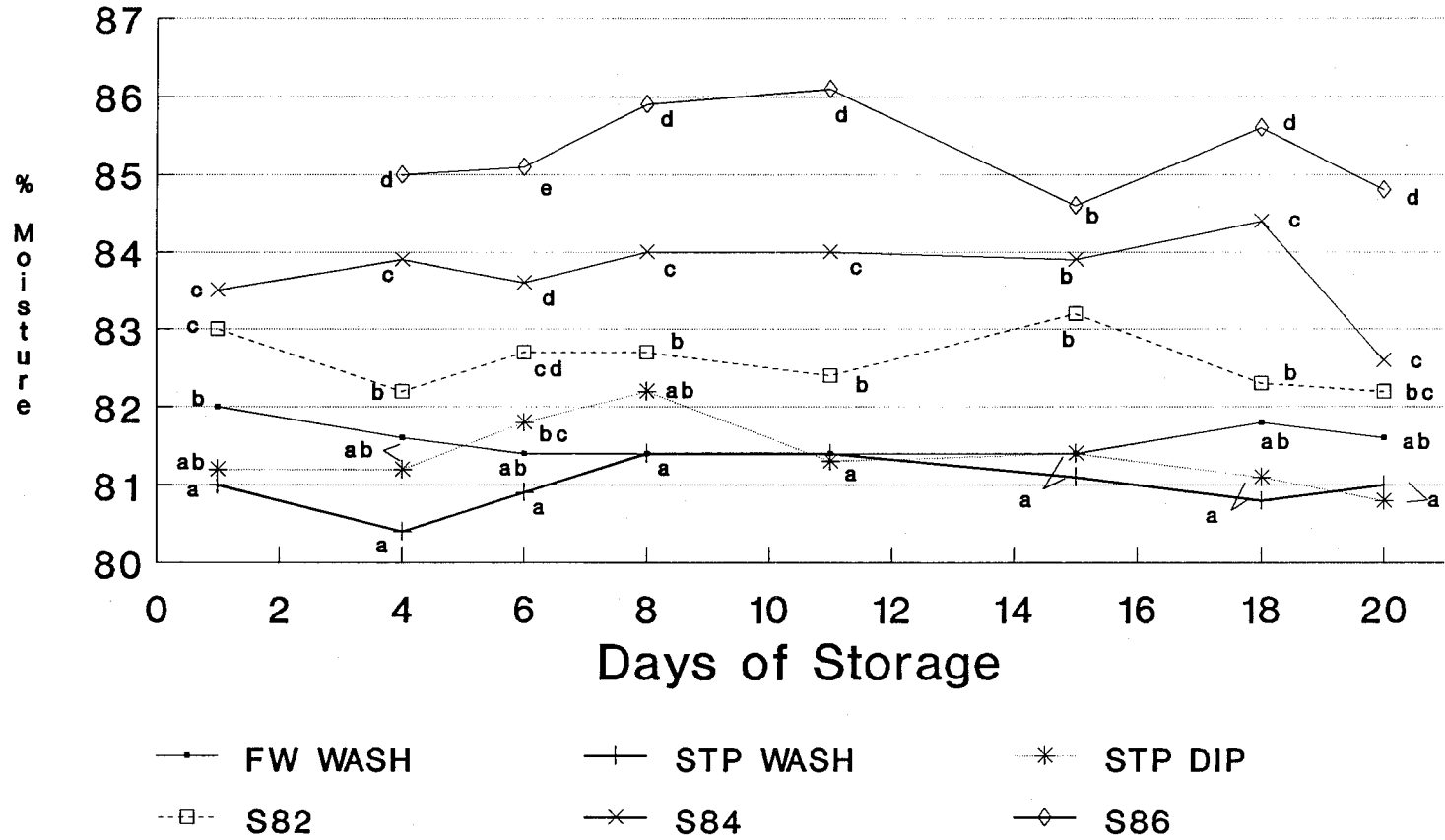

Means each day designated by diff. letters are signif. different,  $p < 0.05$

# Figure 4. Scallop pH During Iced Storage

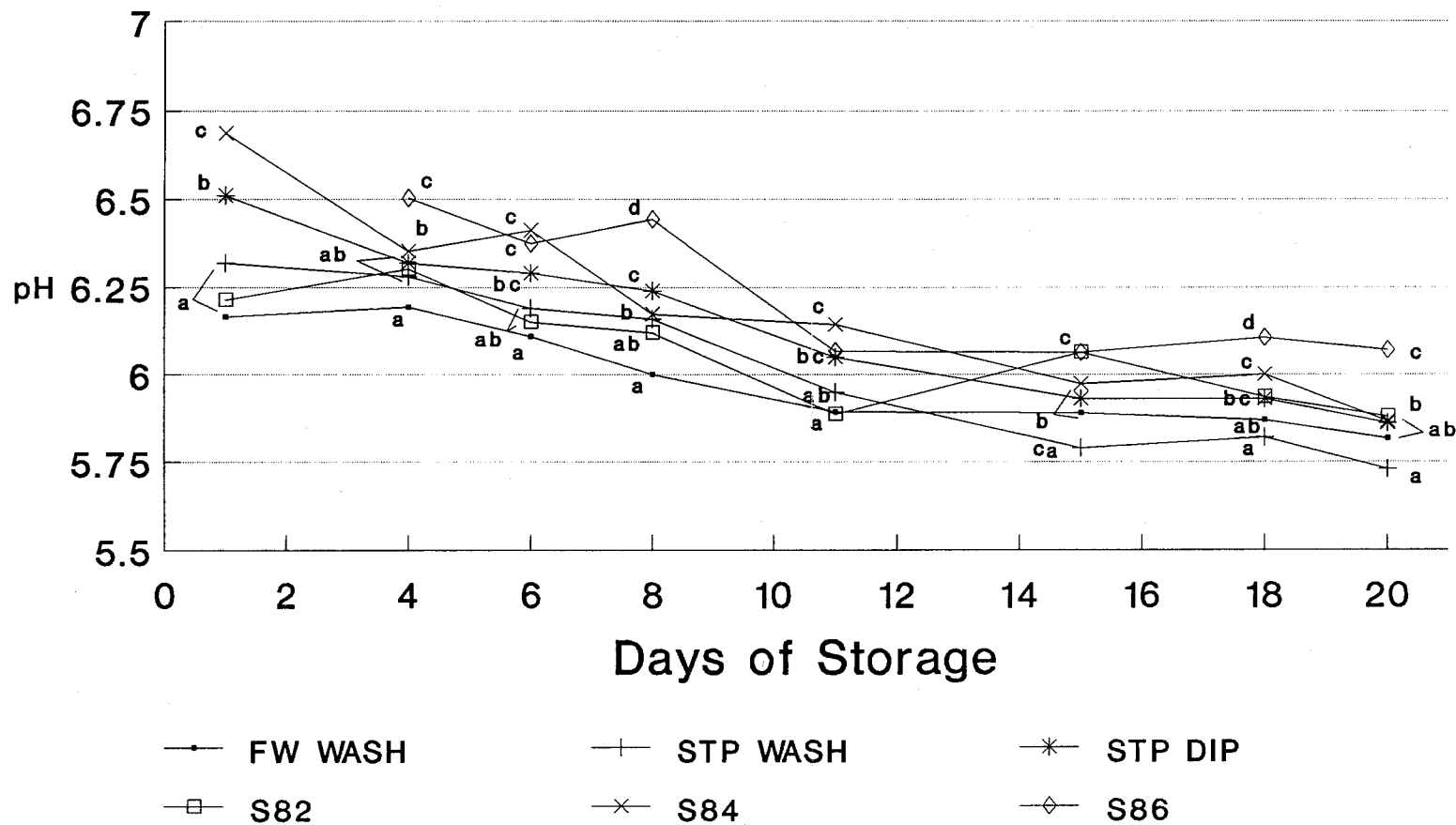

Means each day designated by diff. letters are signif. different,  $p < .05$

# Figure 5. Scallop Aerobic Plate Counts (20C) During Iced Storage

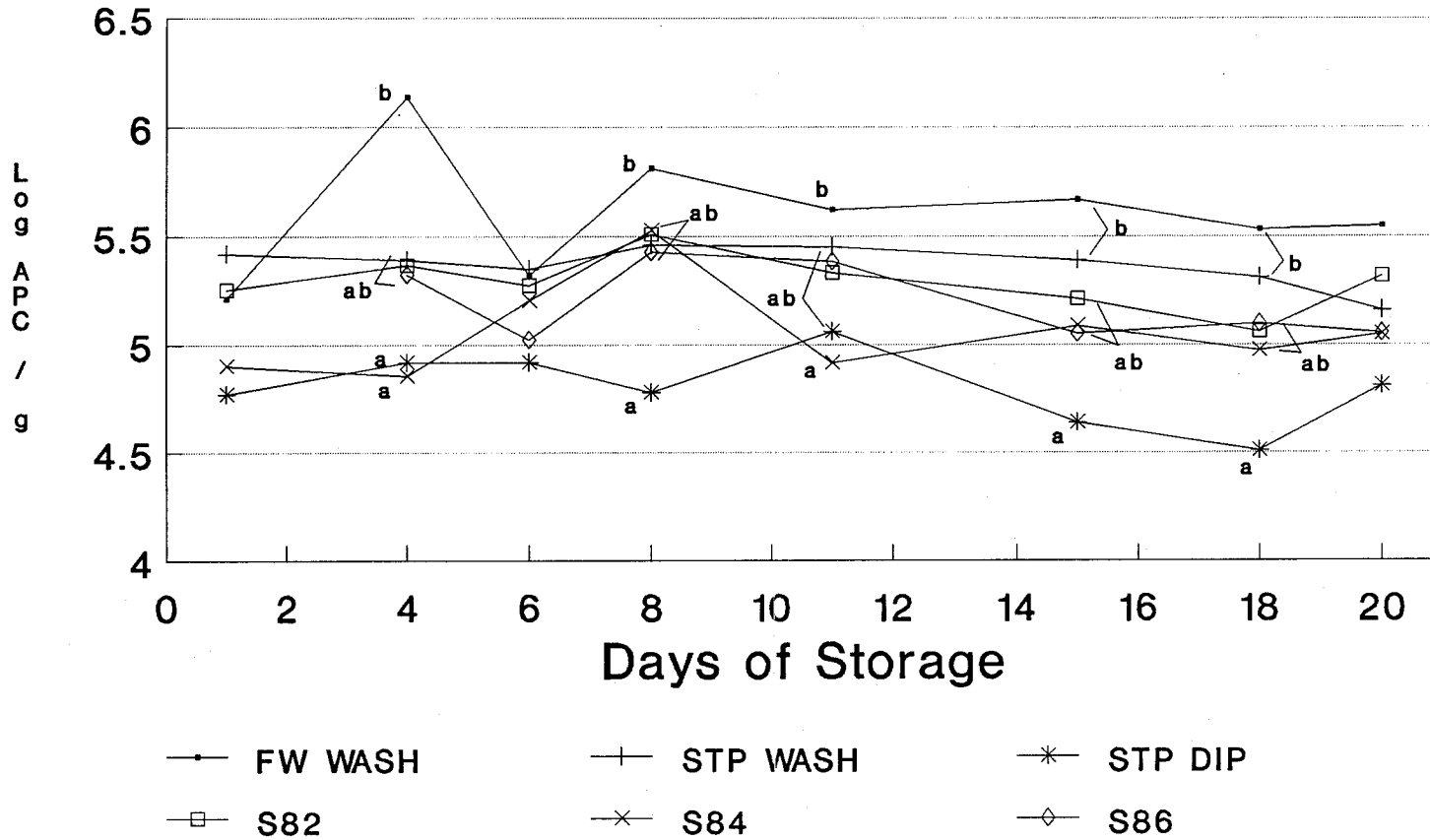

Means each day designated by diff. letters are signif. different, p < .05

# Figure 6. Scallop Drip Loss During Iced Storage

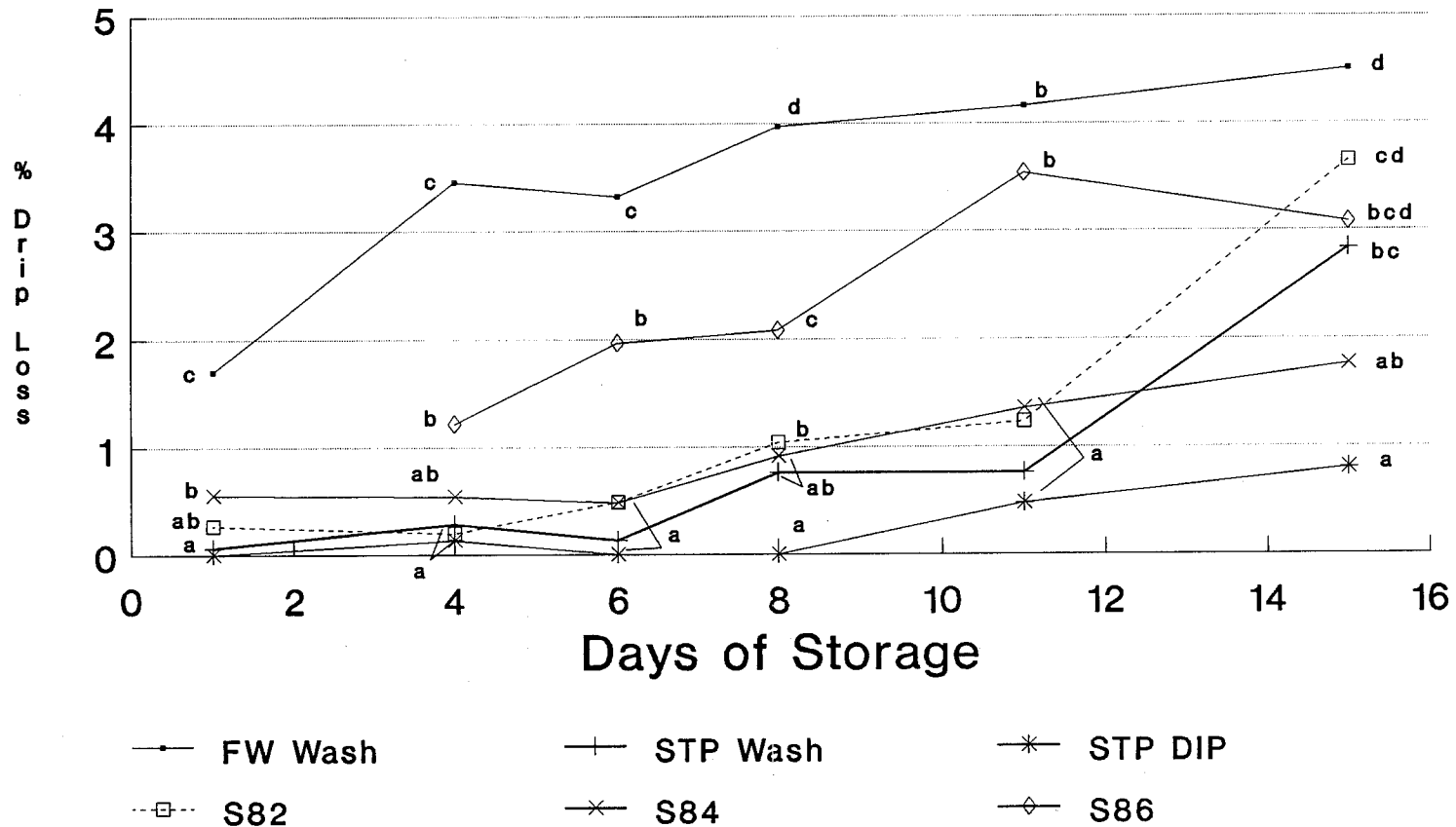

Means each day designated by diff. letters are signif. different,  $p < .05$

# Figure 7. Scallop Cook Losses During Iced Storage

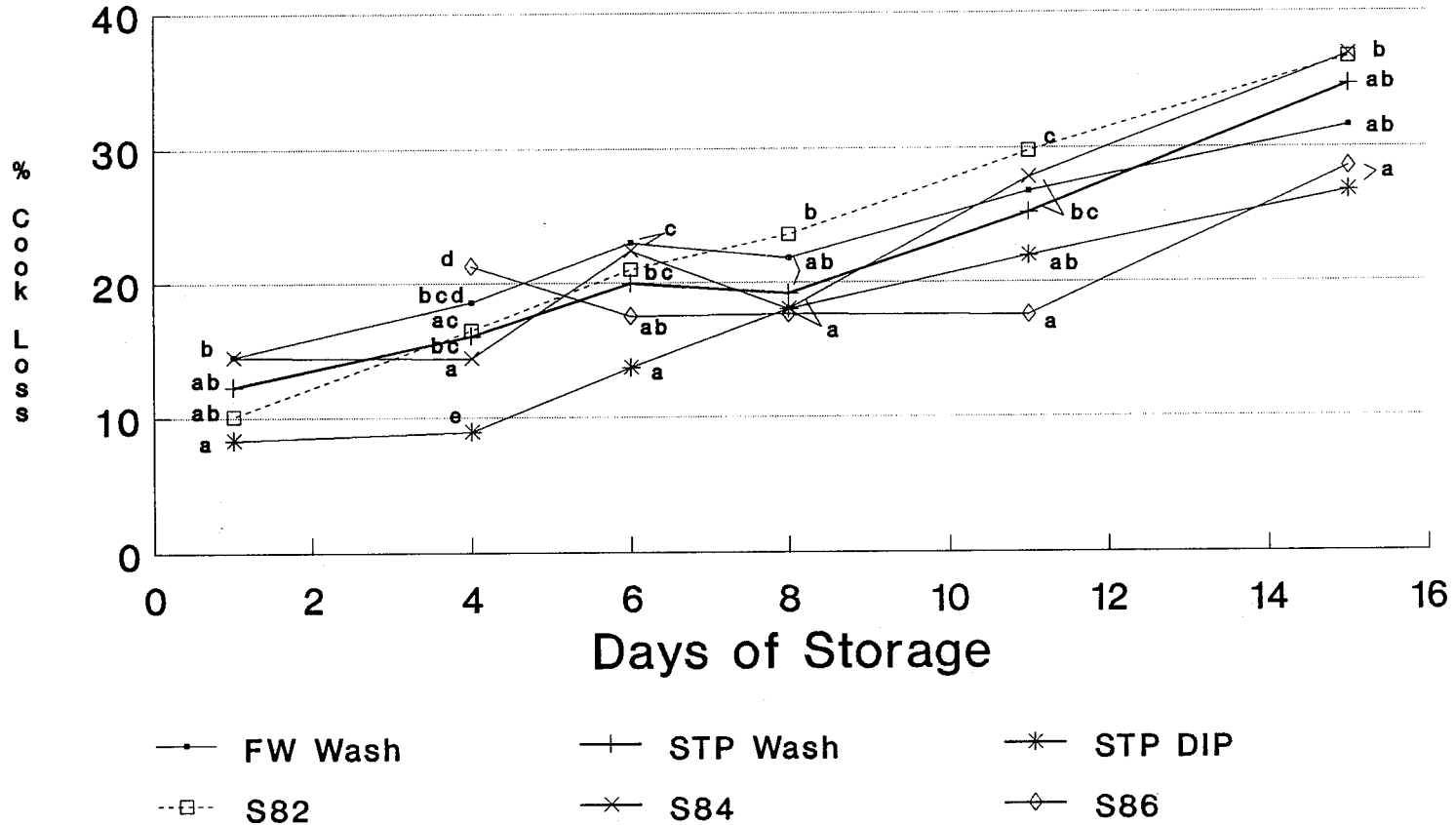

Means on each day designated by diff. letters are signif. different,  $p < 0.05$

# Figure 8. Combined Scallop Drip and Cook Losses

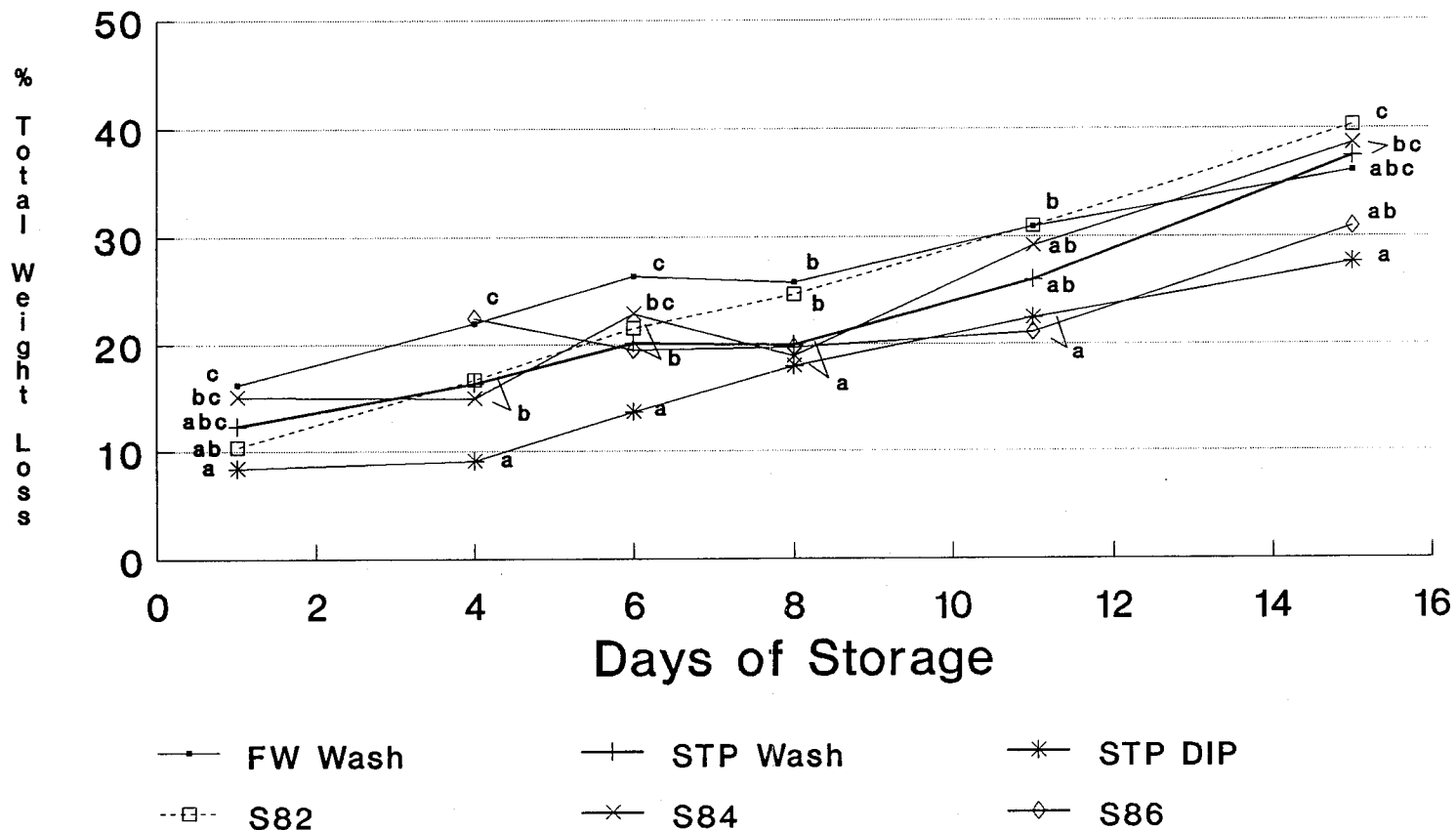

Means each day designated by diff. letters are signif. different, p < .05.



# Figure 9. Raw Scallop Appearance Score During Iced Storage.

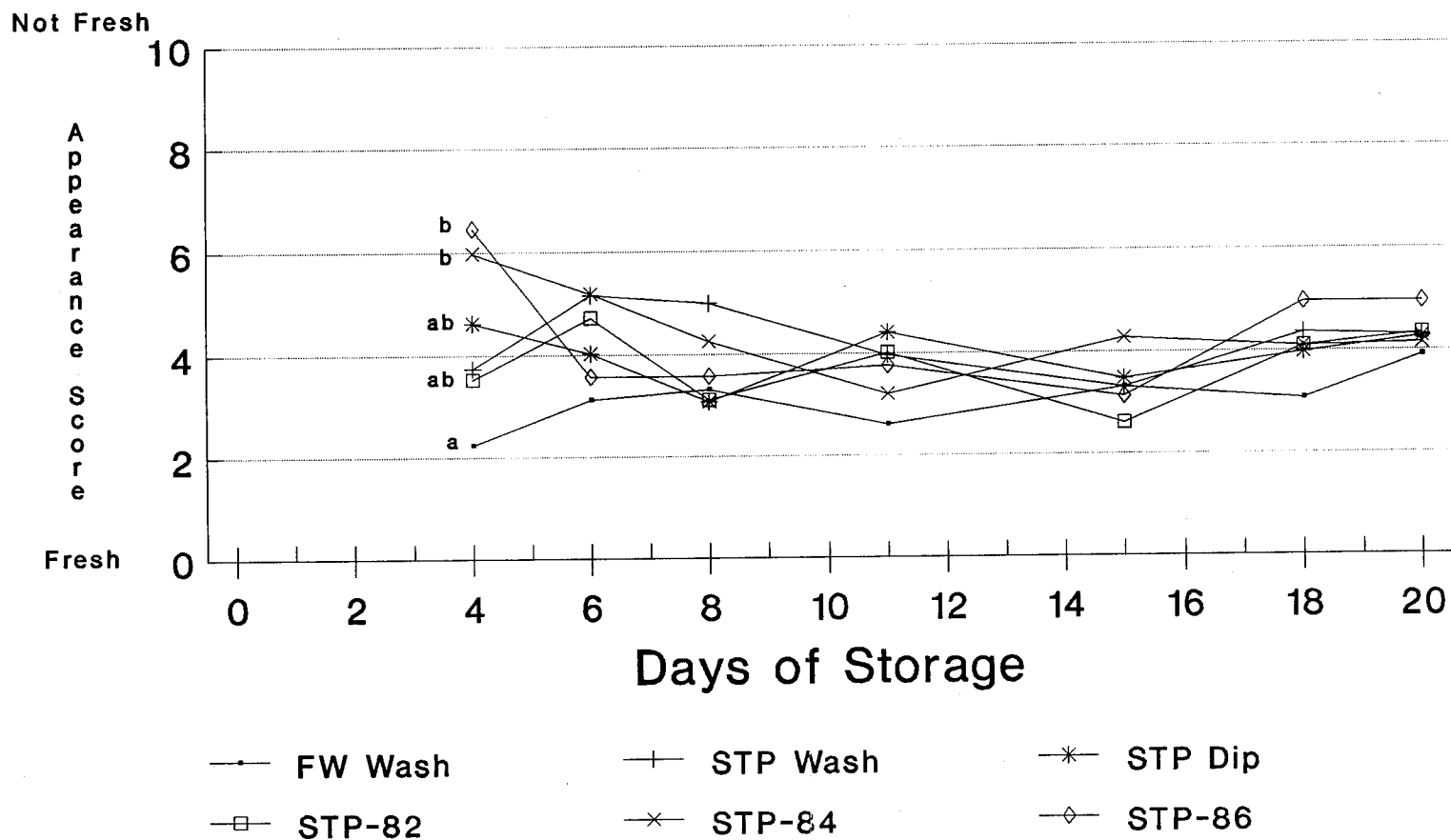

Means on each day designated by diff. letters are signif. different,  $p < .05$ .

# Figure 10. Raw Scallop Odor Scores During Iced Storage

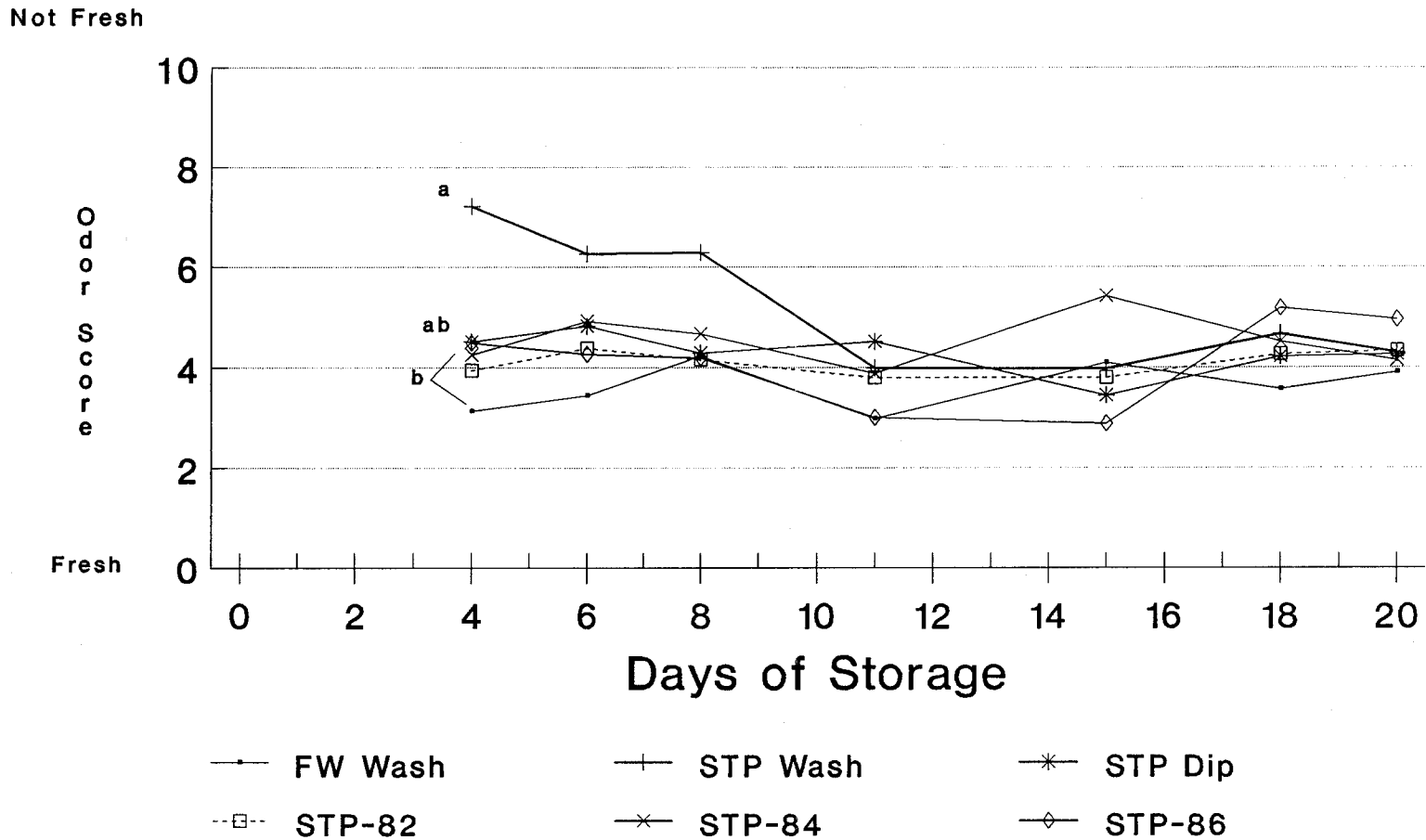

Means each day designated by diff. letters are signif. different,  $p < .05$

# Figure 11. Cooked Scallop Appearance Scores During Iced Storage

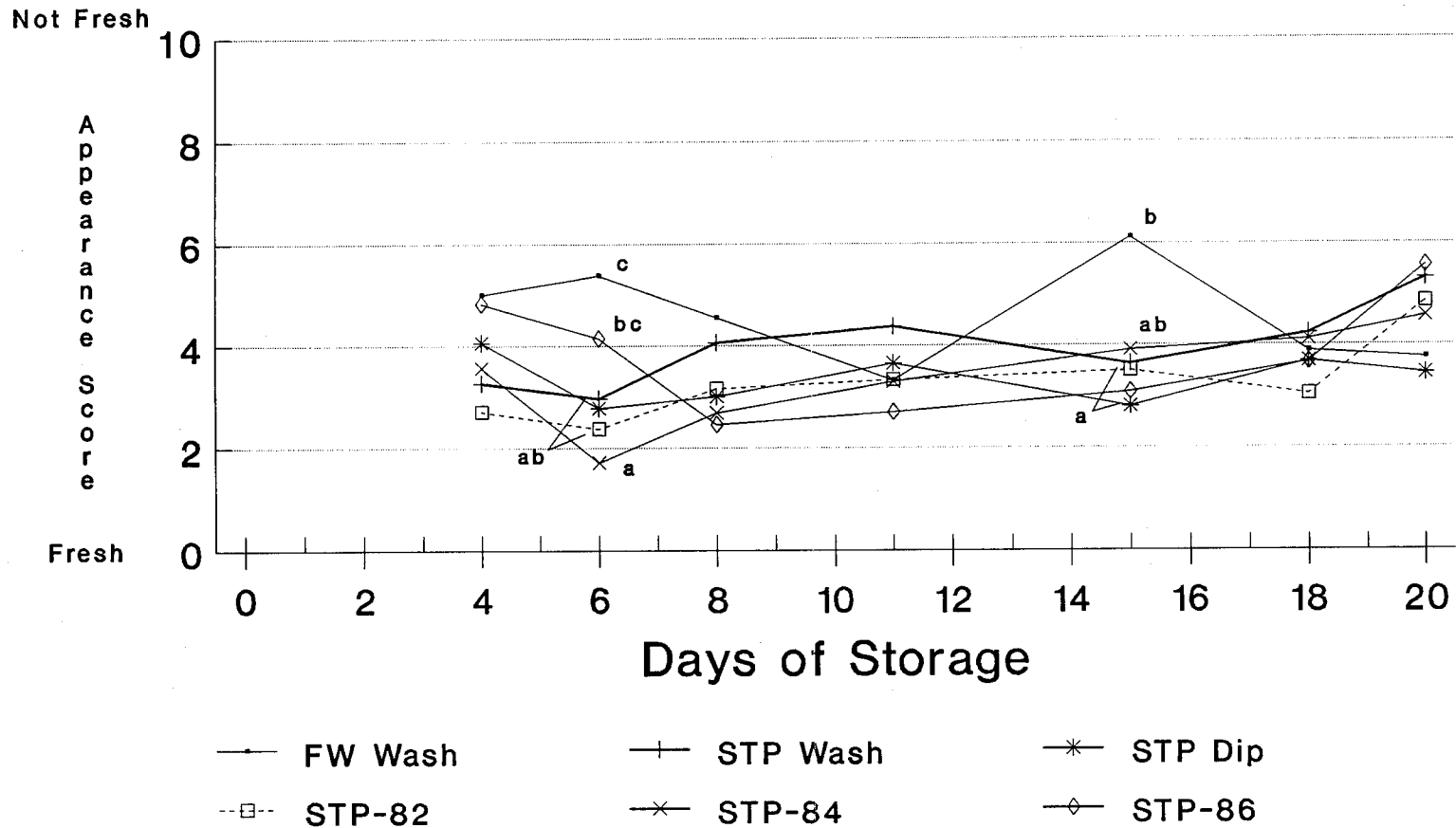

Means each day designated by diff. letters are signif. different,  $p < .05$

# Figure 12. Cooked Scallop Odor Scores During Iced Storage

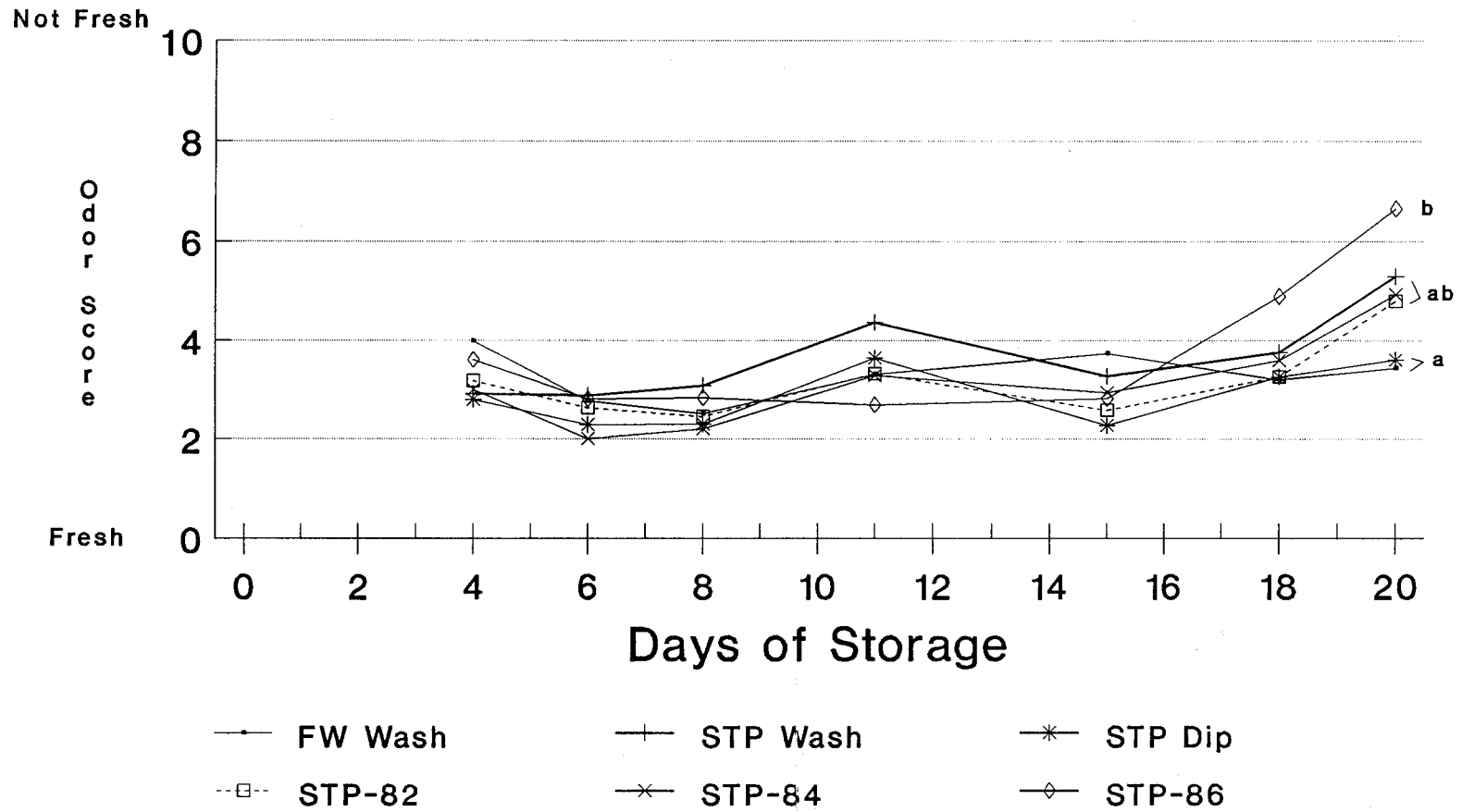

Means each day designated by diff. letters are signif. different,  $p < .05$

# Figure 13. Cooked Scallop Flavor Scores During Iced Storage

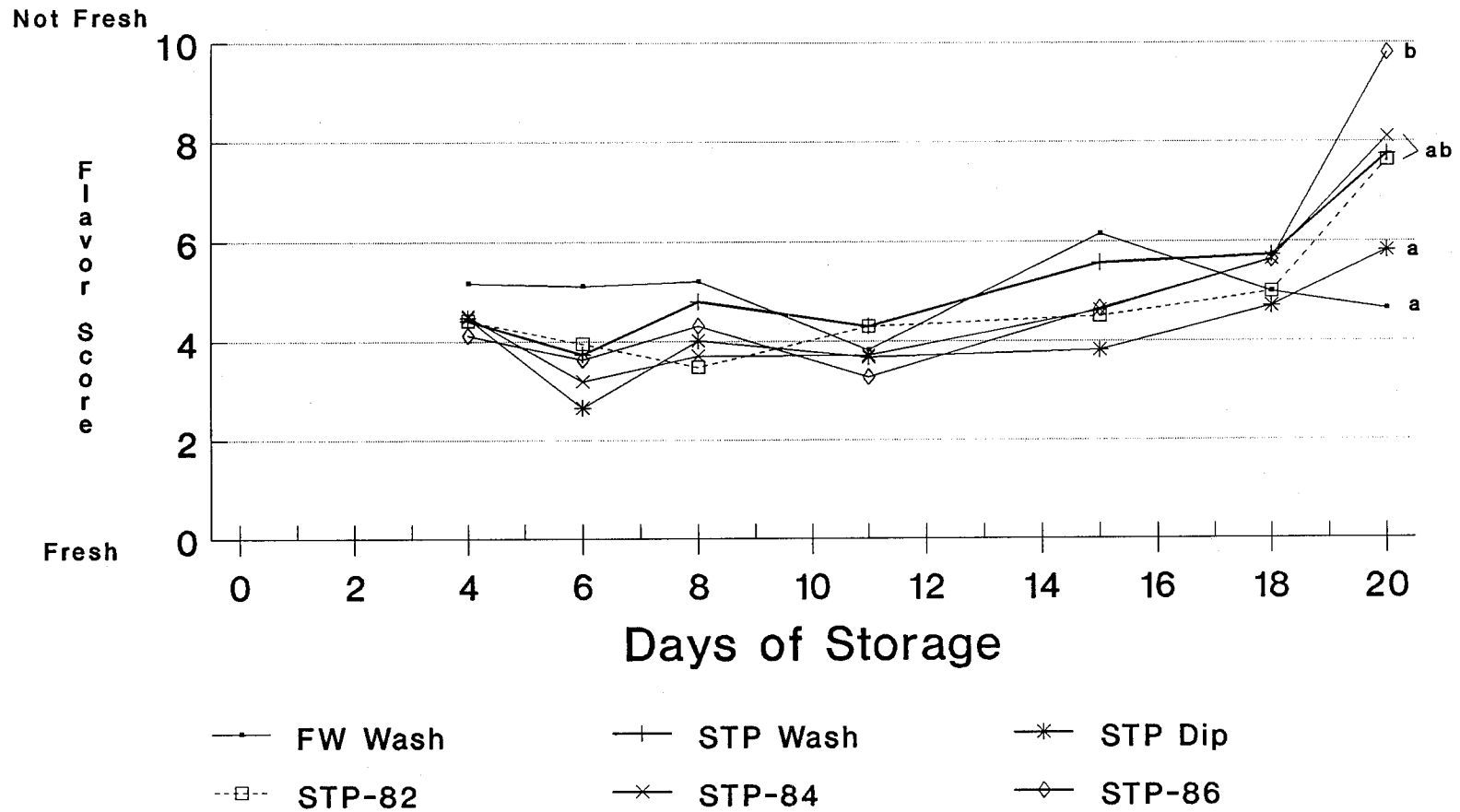

Means each day designated by diff. letters are signif. different,  $p < .05$

# Figure 14. Cooked Scallop Texture Scores During Iced Storage

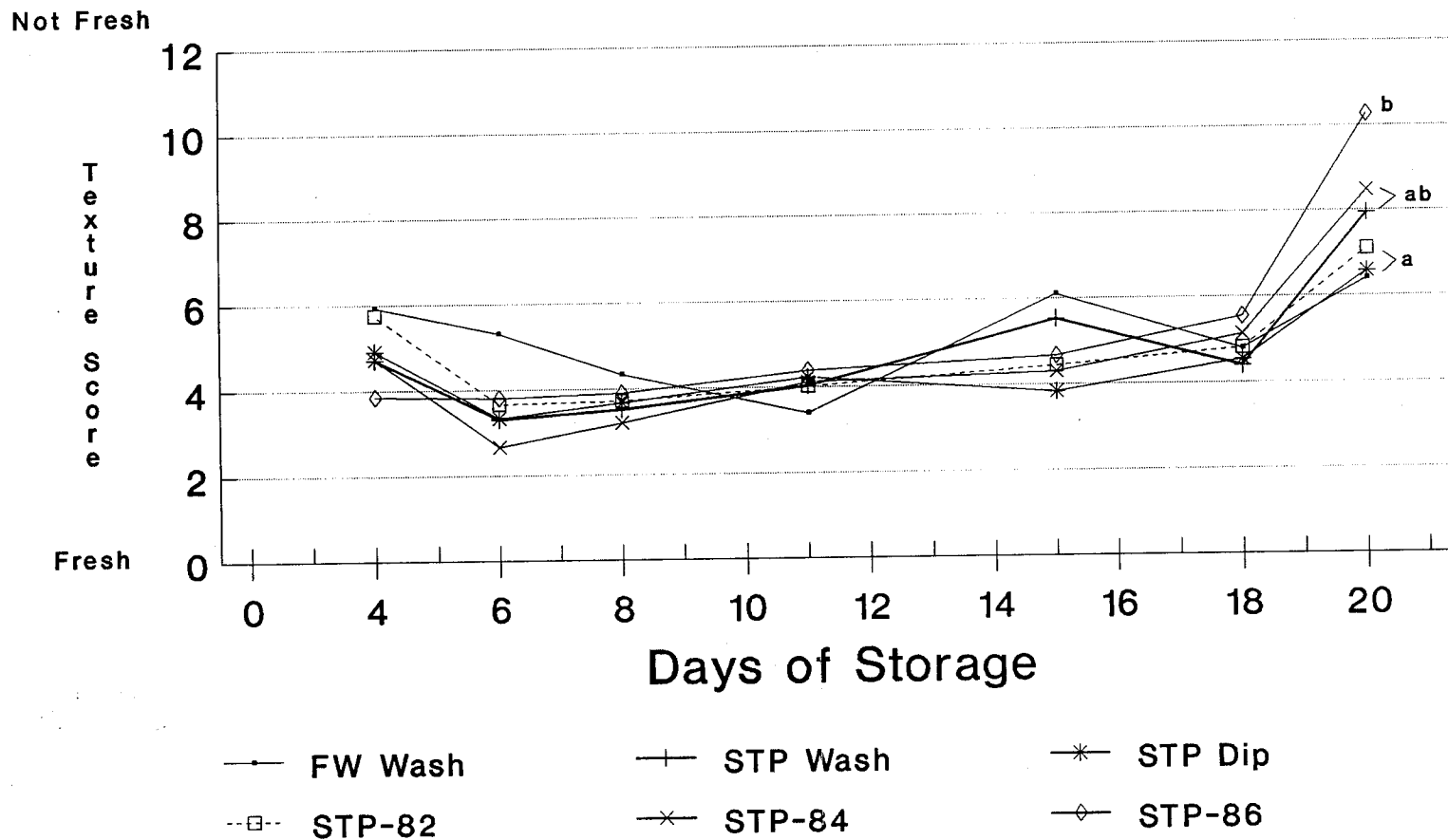

Means each day designated by diff. letters are signif. different,  $p < .05$

## SECTION 4. CONSUMER DISCRIMINATION AND PREFERENCE OF PHOSPHATED SCALLOPS

### Methods

This sampling scheme provided five phosphate product treatments and one non-treated control. All samples were frozen (-20°C) for less than 40 days prior to thawing (slow rate, 10°C with no water contact) for the organoleptic evaluations. All thawed samples were broiled by predetermined procedures that involved continuous monitoring with an Omega 2176A digital temperature recorder connected to Omega T type insulated thermocouples inserted in the scallop meats to monitor for an internal product temperature of 160°F (71°C). The scallops were cooked single layered on a boiler pan for drainage in a conventional oven-boiler. The cooked product was held warm and covered without dehydration before serving.

The product evaluations occurred in two progressive stages. The first stage was a discriminative test involving experienced panelists in a more analytical setting (Department of Food Science and Human Nutrition labs, University of Florida). The panelists were food scientists and students familiar with discriminative product testing and scallops. This test focused on consumer ability to detect actual differences between the treatment variables. Judgements were based on appearance and taste of cooked samples. The procedure used was a triangle test in which the panelist was asked to distinguish the odd or different sample amongst three cooked samples. The two similar samples were either a phosphated sample or a control (freshwater wash). The plate presentation of the odd to similar samples was duplicated in reverse arrangement for all phosphated versus control sample combinations per trial. All different variable combinations were presented in random order through two complete trials to provide four replica encounters with each combination during six days of sequential servings. The data was recorded as percent correct judgements or product distinction for the odd sample.

The second stage in organoleptic testing involved 113 consumers randomly recruited by phone and prescreened for age, sex, level of income and familiarity with eating broiled scallops (Table 15). The consumers were assembled in a high school cafeteria in Greenville, South Carolina which had adjacent facilities for cooking and holding the scallops prior to serving. The consumers were divided into six subgroups with directors assigned to help each group as they progressed through a series of questions and ratings. The consumers were briefed before, during and after the product evaluations to assure their understanding of the questions and rating system. Ratings were based on actual product observations and consumption. Broiled sea scallops from the five treatments and the control were presented as one variable per setting delivered in random order. Each coded sample was presented and evaluated before proceeding to the next sample. No two groups rated the same product at the same time. The consumers were unaware of the test variables. Ratings were based on a 1 to 7 point scale for a series of 17 questions addressing relevant appearance, aroma, flavor, and texture characteristics, plus product quality and value perceptions (Appendix 8). The average total evaluation time per consumer for six samples was one hour. Each panelist that properly completed their evaluation forms was paid \$25 to assure their concentrated participation. An exit interview assured each questionnaire was understood and properly completed before payment. The ratings were analyzed for mean differences and variance with significance ( $\alpha=0.05$ ) based on the Walker-Duncan k-ratio test (SAS, 1992).

## Results and Discussion

The moisture content of the raw and broiled scallops demonstrates the variable influence of the phosphate treatments (Refer to Tables 6 and 7 in Section 2). In general, increased processing times increased the moisture content in raw and cooked scallop meats. The most significant influence was a 6.0 percent change in raw moisture content from the FW Wash treatment (control) to the STP Processed 24 hours. The percent change in moisture content due to broiling ranged from 3.7 to 4.9 percent. The control samples lost the most water while the STP Dip for one minute lost the least. All phosphate treated samples contained more total moisture than the untreated controls after cooking.



Based on percent correct judgements in the series of triangle comparison tests, the majority of panelists were able to distinguish each phosphated treatment from the controls (Table 16). The ability to distinguish the phosphated product from the non-phosphated controls could not be explained by the differences in moisture content in the cooked samples. Although the 10% STP Dip yielded a cooked moisture content of 78%, approximately half of the panelists could not distinguish this treated product. Product distinction was more obvious for products phosphated in treatments with less than 4% STP Wash. Product distinctions for longer processing times (STP Processed 13 and 24 hours) become more evident with panel experience (trial 1 versus trial 2). In general, the influence of the phosphating treatments on cooked scallop appearance and taste involved attributes that could not be explained by total moisture content alone.

Before tasting the scallops in the second stage of consumer evaluations, the recruited participants were asked to rate product appearance and aroma (Table 17). There was no significant difference in ratings for appearance or aroma amongst all phosphate treatments or the control. At least 64% of the consumers 'liked' (rating  $\geq 5$ ) all the products. The phosphate treatments were not distinguished or preferred by appearance or aroma.

After rating appearance and aroma the consumers were asked to take a bite of a cracker and take two sips of water before eating at least two scallops from the treatment they were currently rating. The consumers scored a flavor preference for the phosphated products (Table 18). The majority of consumers liked all scallop treatments, but the average rating for flavor was significantly lowest for the untreated controls. The accompanying question (not in Table 18) to rate flavor strength (1-very weak to 7-very strong) resulted in a significant preference for the highest rated (mean, 4.9) STP Dip. Over 66% of the consumers 'liked' (ratings  $\geq 5$ ) this phosphated product as compared to 47% 'liking' the least rated controls (mean, 4.3).

When asked to rate salty taste the consumers generally rated the products as being either some variation of "not salty enough" or "just right" (Table 18). Salty taste was not a detrimental attribute in phosphated scallops. The accompanying question (not in Table 18) to rate the degree of salty taste, resulted in average scores less than 3.6 for all treatments. This rating was based on a scale of 1 denoting 'very weak salty taste', 4-'just right'

and 7-'very strong'. In general the consumers would have preferred a higher salt flavor. The highest sodium content in the cooked meats was 480 mg/100 ml from the STP Processed 24 hour scallops (Table 12).

There was no discernible pattern in ratings for aftertaste relative to the phosphate or control treatments (Table 18). Aftertaste was noted in all products, but it was not considered to be a negative attribute.

When asked to rate cooked scallop texture and firmness the consumers gave a confused response (Table 19). There was no significant difference in mean ratings for firmness, yet there were scattered differences in ratings for texture. More consumers (71% to 82%) 'liked' the texture of the phosphated scallops, but the instructors felt the consumers were confused by the term 'texture'.

The consumers were able to distinguish the phosphated products with higher moisture contents (Table 19). Moist mouthfeel was not considered as a negative attribute. In the accompanying question (not in Table 19) for how the consumers felt about the moist mouthfeel (ratings: 1-too dry, 4-just right, 7-too moist), the largest majority of consumers (69%) rated the moist mouthfeel of the STP Processed 24 hour scallops as 'just right'. Only 43% of the consumers gave the same rating for the controls. Similar high ratings for the other phosphated products were scored by 60% to 61% of the consumers. The phosphate treatments imparted a preferred moist mouthfeel in the cooked products.

When asked to compare the test scallops to ones the consumers normally ate and scallops they expect in a restaurant, most consumers basically felt all the test products were the "same as" or "better than" their usual scallops (Table 20). The controls were rated lowest in both categories. The highest mean ratings for product expectations was for STP Processed scallops.

Overall, product perceptions rated in response to questions on 'likableness, quality, and product value' reflect a consistent pattern of preference for the phosphated products (Table 21). Over 64% of all consumers 'liked' all scallop products, and 83% of the 'likable' ratings preferred the previously phosphated scallops with a raw meat moisture content of 83.9% (STP Processed 24 hour). Similarly, the higher mean ratings for product 'quality' were scored for all scallops STP Processed; yet, these higher ratings could not be statistically distinguished ( $\alpha=0.05$ ) from the other phosphate treatments.

When told the average retail price for the raw scallops was \$6.99 per pound and asked how they would feel about the 'value' if the previously evaluated products had been purchased at that price, the consumers demonstrated price resistance, but a value preference for the phosphated products (Table 21).

## Conclusions

In terms of the parameters of this study, consumer evaluations have demonstrated a distinct preference for phosphated scallops in comparison to untreated products. The addition of moisture and ability to hold water in cooked scallops can provide a consumer benefit in terms of flavor and moist mouthfeel. There was no distinct objection to phosphated product appearance, aroma or aftertaste, and additional salt taste was desired. Ratings for product texture and firmness were confused by terminology and consumer interpretation, but there was no discernible objection to phosphated product texture or firmness. Overall, the consumers generally felt the phosphated scallops meet their expectations and they liked and judged the products to be of high quality and valued more than the non-phosphated scallops. Although, initial discriminative tests demonstrated the consumers ability to distinguish the phosphated products from the non-phosphated controls, there was limited distinction in product ratings and preference amongst the various phosphate treatments. Further consumer testing is warranted to optimize the most cost-effective phosphate treatments to impart the most favorable consumer attributes in cooked scallops.

**Table 15.** Demographics and scallop consumption pattern for the 113 consumers prescreening for product evaluations.

a. Demographics					
<u>Age</u>	<u>Income</u>		<u>Education</u>		<u>Family Size</u>
years (%)	\$ (%)		years (%)		No. (%)
18-34 (35)	< 20K	(17)	< 12	(3)	1 (12)
35-44 (29)	to 35K	(35)	to 12	18)	2 (29)
45-54 (26)	to 50K	(22)	12+	(34)	3 (27)
55-60 (10)	to 75K	(19)	12+4	(35)	4 (21)
	> 75K	(7)	> 12+4	(10)	5+ (12)

b. Scallop Consumption or Product Familiarity			
<u>Frequency Consumption</u>	<u>At Home</u>	<u>Restaurant</u>	<u>Favorite Recipe</u>
Never	30%	1%	Steam 5%
Once/6 mo.	29%	24%	Broil 25%
Once/3 mo.	29%	58%	Saute 24%
> 1/3 mo.	12%	17%	Fried 26%
			Other 1%

**Table 16.** Discrimination test results for 24 panelists attempting to identify or judge any noticeable difference between cooked samples of control versus phosphate treated scallops.

Product Compared to Controls	<sup>1</sup> % Total Correct Judgements		<sup>2</sup> % Moisture Content Cooked
	Trial 1	Trial 2	
Control	—	—	75.6
10% STP/1 min.	58	52	78.0
4% STP/20 min.	69	66	76.9
2.5% STP/5 hr.	73	71	77.7
2.5% STP/13 hr.	66	83	79.5
2.5% STP/24 hr.	77	85	80.6

STP - Sodium tripolyphosphate, plus 1% sodium chloride.

<sup>1</sup> A recorded "correct judgement" required proper product identification in both replicates of the control versus phosphate samples in triangle paired comparisons per each trial.

<sup>2</sup> Moisture content data from Table 8.

**Table 17.** Mean ratings for the appearance and aroma and the respective total % 'like' ratings ( $\geq 5$ ) for broiled scallops from all treatments.

Product Treatments	Appearance		Aroma	
	Mean	% like	Mean	% like
Control	5.4a	70	5.3a	73
<u>% STP</u>				
10/1 min.	5.3a	67	5.3a	74
4/20 min.	5.4a	73	5.5a	78
2.5/5 hr.	5.3a	71	5.3a	74
2.5/13 hr.	5.2a	64	5.4a	74
2.5/24 hr.	5.5a	77	5.5a	75

STP - sodium tripolyphosphate, plus 1% sodium chloride.

Appearance and aroma ratings: 1-dislike very much to 7-like very much.

Statistical significance differences ( $\alpha = 0.05$ ) are denoted by any two means labeled with different lower case letters.

**Table 18.** Consumer perception ratings for flavor, saltiness and aftertaste in broiled scallops from all product treatments. The total % 'like' and 'salty' ratings include all consumers scoring  $\geq 5$ .

Product Treatments	Flavor		Saltiness		Aftertaste
	Mean	% like	Mean	% salty	Mean
Control	4.9a	66	2.3a	10	3.9ab
<u>% STP</u>					
10/1 min.	5.3 b	77	2.6ab	14	4.0ab
4/20 min.	5.6 c	82	2.7ab	14	4.2 b
2.5/5 hr.	5.6 bc	82	2.7ab	9	3.6a
2.5/13 hr.	5.5 bc	77	2.9 b	17	4.0ab
2.5/24 hr.	5.7 c	82	2.8 b	17	3.5a

STP - sodium tripolyphosphate, plus 1% sodium chloride.

Flavor ratings: 1-dislike very much to 7-like very much; 'like' is ratings  $\geq 5$ .

Saltiness ratings: 1-not salty at all to 7-very salty; 'salty' is ratings  $\geq 5$ .

Aftertaste ratings: 1-very weak to 7-very strong.

Statistical significant differences ( $\alpha = 0.05$ ) are denoted by any two means labeled with different lower case letters.

**Table 19.** Consumer perception ratings for texture, firmness and mouthfeel in broiled scallops from all product treatments. The total % 'like', 'firm' and 'moist' ratings include all consumers scoring  $\geq 5$ .

Product Treatments	Texture		Firmness		Moistness	
	Mean	% like	Mean	% firm	Mean	% moist
Control	5.0a	65	4.8a	63	4.3a	42
<u>% STP</u>						
10/1 min.	5.2ab	71	5.0a	65	4.8 bc	52
4/20 min.	5.6 b	82	5.2a	76	4.7ab	51
2.5/5 hr.	5.3ab	74	4.9a	62	4.9 bc	60
2.5/13 hr.	5.3ab	74	4.8a	62	4.8 bc	57
2.5/25 hr.	5.6 b	78	4.8a	60	5.1 c	67

STP - sodium tripolyphosphate, plus 1% sodium chloride.

Texture ratings: 1-dislike very much to 7-like very much; % 'like' is ratings  $\geq 5$ .

Firmness ratings: 1-too firm, 4-just right, 7-too firm; % 'firm' is ratings  $\geq 5$ .

Moistness ratings: 1-very dry to 7-very moist; % 'moist' is ratings  $\geq 5$ .

Statistical significant differences ( $\alpha = 0.05$ ) are denoted by any two means labeled with different lower case letters.



**Table 20.** Consumer perception ratings or comparisons for the test scallops relative to consumers usual and restaurant expectations. The total % 'better' or 'same' ratings include all consumers scoring  $\geq 5$ .

Product Treatments	Usually Expect.			Restaurant Expect.		
	Mean	% better	% same	Mean	% better	% same
Control	3.8a	28	28	3.7a	32	23
<u>% STP</u>						
10/1 min.	4.1ab	33	31	4.0ab	28	34
4/20 min.	4.2ab	38	29	4.1ab	29	39
2.5/5 hr.	4.2ab	38	32	4.2 bc	43	28
2.5/13 hr.	4.4 b	45	22	4.4 bc	45	22
2.5/25 hr.	4.5 b	47	23	4.5 c	48	24

STP - sodium tripolyphosphate, plus 1% sodium chloride.

Usual Expectations: 1-much worse, 4-same, 7-much better; % 'better' or 'same' is ratings  $\geq 5$ .

Restaurant Expectations: 1-worse, 4-same, 7-much better; % 'better' or 'same' is ratings  $\geq 5$ .

Statistical significant differences ( $\alpha = 0.05$ ) are denoted by any two means labeled with different lower case letters.

**Table 21.** Consumer perception ratings for overall scallop product 'likableness, quality and value' based on previous evaluations of broiled samples. Value judgements were based on a provided raw product cost of \$6.99 per pound.

Product Treatments	Likableness		Quality		Value		
	Mean	% like	Mean	% high qual.	Mean	% bargain	% fair price
Control	4.9a	64	4.4a	47	3.5a	22	31
<u>% STP</u>							
10/1 min.	5.1ab	71	4.7ab	59	3.7ab	20	37
4/20 min.	5.3ab	74	4.8ab	60	3.9ab	27	33
2.5/5 hr.	5.4ab	79	5.0 b	65	3.9ab	30	34
2.5/13 hr.	5.3 b	75	5.0 b	66	4.0 b	29	37
2.5/25 hr.	5.5 b	83	2.2 b	66	4.0 b	30	37

STP - sodium tripolyphosphate, plus 1% sodium chloride.

Likableness scale: 1-dislike very much to 7-like very much; % like is ratings  $\geq 5$ .

Quality scale: 1-very low quality to 7-very high quality; % high quality is ratings  $\geq 5$ .

Value scale: 1-paid too much, 4-'fair price' to 7-got a bargain; % bargain is ratings  $\geq 5$ .

Statistical significant differences ( $\alpha = 0.05$ ) are denoted by any two means labeled with different lower case letters.

## REFERENCES

- AOAC. 1980. Official Methods of Analysis, 14th ed., Association of Official Analytical Chemists, Arlington, VA.
- AOAC. 1990. Official Methods of Analysis, 15th ed., Association of Official Analytical Chemists, Arlington, VA.
- CFR. 1990. Code of Federal Regulations, 21. Parts 100 to 169, 4-1-90. U.S. Government Printing Office, Washington, DC.
- CFR. 1986. United States Standards for Grades of Frozen Raw Scallops. Code of Federal Regulations, Title 50: 266.111.
- DuPaul, William D., Robert A. Fisher and James E. Kirkley. 1991. Effects of deck treatments and thermal abuse on weight changes in shucked sea scallops (Placopecten magellanicus) during stowage. Proc. 15th Annual Tropical and Subtropical Fisheries Technological Conference of the Americas. Univ. of Florida, Florida Sea Grant College Program, SGR-105.
- DuPaul, William D., Robert A. Fisher and James E. Kirkley. 1990. An evaluation of at-sea handling practices: effects of sea scallop meat quality, volume and integrity. Contract Report to the Gulf and South Atlantic Fisheries Development Foundation. 76 pp.
- Elliot, R., R. Straka, and J. Garibaldi. 1964. Polyphosphate inhibition of growth of pseudomonads from poultry meat. Appl. Microbiol. 12: 517.
- FDA. 1992. [Interim guidelines for product labeling and moisture content allowance for phosphated scallops]. Office of Seafood, U.S. Food and Drug Administration, August. 2 pp.
- Federal Register. Vol. 57, No. 45, March 6, 1992. Nutrition labeling provided by FDA for the 20 most frequently consumed fish, VIII. Appendix B, p. 8175.
- Federal Register. 1979. Phosphates; proposed affirmation of and deletion from GRAS status as direct and human food ingredients. Action: Proposed Rule. 44(244)74845.
- Firstenberg-Eden, R., D. Rowley, and E. Shattuck. 1981. Inhibition of *Moraxella-Acinetobacter* cells by sodium phosphate and sodium chloride. J. Food Sci. 46: 579.
- Fisher, R. A., J. E. Kirkley and W. D. DuPaul. 1990. Phosphate use in processing sea scallops, Placopecten magellanicus in the mid-Atlantic region. Proc. 15th Annual Tropical and Subtropical Fisheries Technological Conference of the Americas. Univ. of Florida, Florida Sea Grant College Program, SGR-105.
- Foster, R., and G. Mead. 1976. Effect of temperature and added polyphosphate on the survival of salmonellae in poultry meat during cold storage. J. Appl. Bacteriol. 41: 505.
- Larmond, E. 1977. Laboratory Methods for Sensory Evaluation of Food. Pub. 1637, Agriculture Canada, Ottawa.
- Lyon, B., and J. Magee. 1984. Effects of sodium chloride and polyphosphate pretreatments on fowl meat processed in flexible pouches. Poult. Sci. 63: 1958.

- Maxwell-Miller, G., R. Josephson, A. Spindler, D. Holloway-Thomas, M. Avery, and C. Phleger. 1982. Chilled (5°C) and frozen (-18°C) storage stability of the purple-hinge rock scallop, *Hinnites multirugosus* Gale. *J. Food Sci.* 47(6): 1654.
- Meilgaard, M., G. Civille and B. Carr. 1991. *Sensory Evaluation Techniques*. CRC Press, Boca Raton, Florida.
- Molins, R.A. 1991. *Phosphates in Food*. CRC Press, Boca Raton, Florida.
- Mukerji, J. 1992. Quality of on-board cryogenically frozen sea scallops (*Placopecten magellanicus*). M.S. Thesis, Dept. of Food Sci. and Techn., Va. Poly. Inst. and St. Univ., Blacksburg.
- Petriefilm™ Recommended Sampling Procedures. 1987. 3M Medical-Surgical Division, St. Paul, Minnesota.
- Power, H., K. Fraser, W. Neal, W. Dyer, C. Castell, H. Freeman, and D. Idler. 1964. Use of gamma radiation for the preservation of scallop meat. *J. Fish Res. Bd. Can.* 21(4): 813.
- Regenstein, J., and J. Stamm. 1979. A comparison of the water holding capacity of pre- and post-rigor chicken, trout and lobster muscle in the presence of polyphosphates and divalent cations. *J. of Food Biochem.* 3: 223.
- Rippen, T., H. Sutton, L. Lampila, C. Hackney and R. Lane. 1990. Shelflife extension and weight retention of sea scallops treated with sodium tripolyphosphate, with and without dissolved carbon dioxide. 50th annual meeting of the Institute of Food Technologists, Anaheim (see Appendix 6).
- SAS. 1992. *Statistical Analysis Systems, User's Guide*. SAS Institute, Inc., Corey, NC.
- Shults, G., D. Russell, and E. Wierbicki. 1972. Effect of condensed phosphates on pH, Swelling and water-holding capacity of beef. *J. of Food Sci.* 37: 860.
- Sidwell, V. D. 1981. *Chemical and Nutritional Composition of Finfish, Whales, Crustaceans, Mollusks and Their Products*. NOAA/National Marine Fisheries Service Technical Memorandum NMFS F/SEC-11, 423 pp.
- Sofos, J. N. 1986. Use of Phosphates in Low-Sodium Meat Products. *Food Technol.* 40(a): 52-69.
- Spencer, J., and S. Smith. 1962. The effect of chilling chicken fryers in a solution of polyphosphates upon moisture uptake, microbial spoilage, tenderness, juiciness and flavor. *Poult. Sci.* 41: 1685.
- Steinhauer, J. and G. Banwart. 1964. The effect of food grade polyphosphates on the microbiol population of chicken meat. *Poult. Sci.* 43: 618.
- USDA Handbook 8-15, *Finfish and Shellfish Products*, 1987.
- Vyncke, W. 1978. Influence of sodium tripolyphosphate and citric acid on the shelf life of Thornback Ray (*Raja clavata* L.). *Z. Lebensm, Unters.-Forsch.* 166: 284.
- Wagner, M. 1986. Phosphates as antibotulinal agents in cured meats: a review. *J. of Food Prot.* 49(6): 482.
- Young, L., C. Papa, C. Lyon, and R. Wilson. 1992. Moisture retention and textural properties of ground chicken meat as affected by sodium tripolyphosphate, ionic strength and pH. *J. of Food Sci.* 57(6): 1291.

Young, L., and B. Lyon. 1986. Effect of sodium tripolyphosphate in the presence and absence of calcium chloride and sodium chloride on water retention properties and shear resistance of chicken breast meat. *Poult. Sci.* 65: 898.



Virginia Institute of Marine Science  
School of Marine Science

P. O. Box 1346  
Gloucester Point, Virginia 23062  
804/642-7000, Fax 804/642-7097, Scats 842-7000

M E M O

TO: NFI/FDA Sea Scallop Technical Committee  
FROM: W. D. DuPaul *W.D. DuPaul*  
SUBJECT: "Straw Man" Concept  
DATE: January 8, 1992

Attached is a draft of a possible concept we could use use to address water uptake and phosphate abuse in the handling and processing of sea scallops. On the product flow diagrams for vessels and processing plants, Bob Fisher and I have identified particular places where added water and/or processing aids may be used. The attached sheets have a bit of narrative with the observed range of weight increases in % corresponding to each of these steps.

Also, I've included a graph which, from a mathematical point, plots % weight increase to a calculated % moisture level. The 0% weight increase and % moisture level corresponds to some ranges we and others have observed for freshly shucked scallops.

A value of 77.4% appears to be a conditional mean based on data from Canada and the U.S. The data points on the graph are from experimental data involving the soaking of scallops in STP solutions. Some of these values are higher than the expected or calculated % moisture levels. This is probably due to the fact that soaked scallop lose proteins and cellular compounds to the soaking medium and thus are lost for the calculation of % moisture of the scallops after soaking.

I would appreciate your review of this "sketch" and I would envision that from a conceptual approach industry would have to come to grips with some values that would be acceptable at each of the identified points of the flow charts. From that point we could then try to develop a set of proposed practices that would fall in line with what industry feels is reasonable. Then the next step would be to get some reaction from FDA to see if we're on the right track.

Let me know what you think of this approach and we can go from there.

WDD:cht  
Attachments

cc: Committee Members: Roy Martin, Bob Collette, Steve Otwell,  
Bob Fisher, Tom Rippen and Brian Veasy



Figure 1. Sea Scallop Vessel Operational Diagram

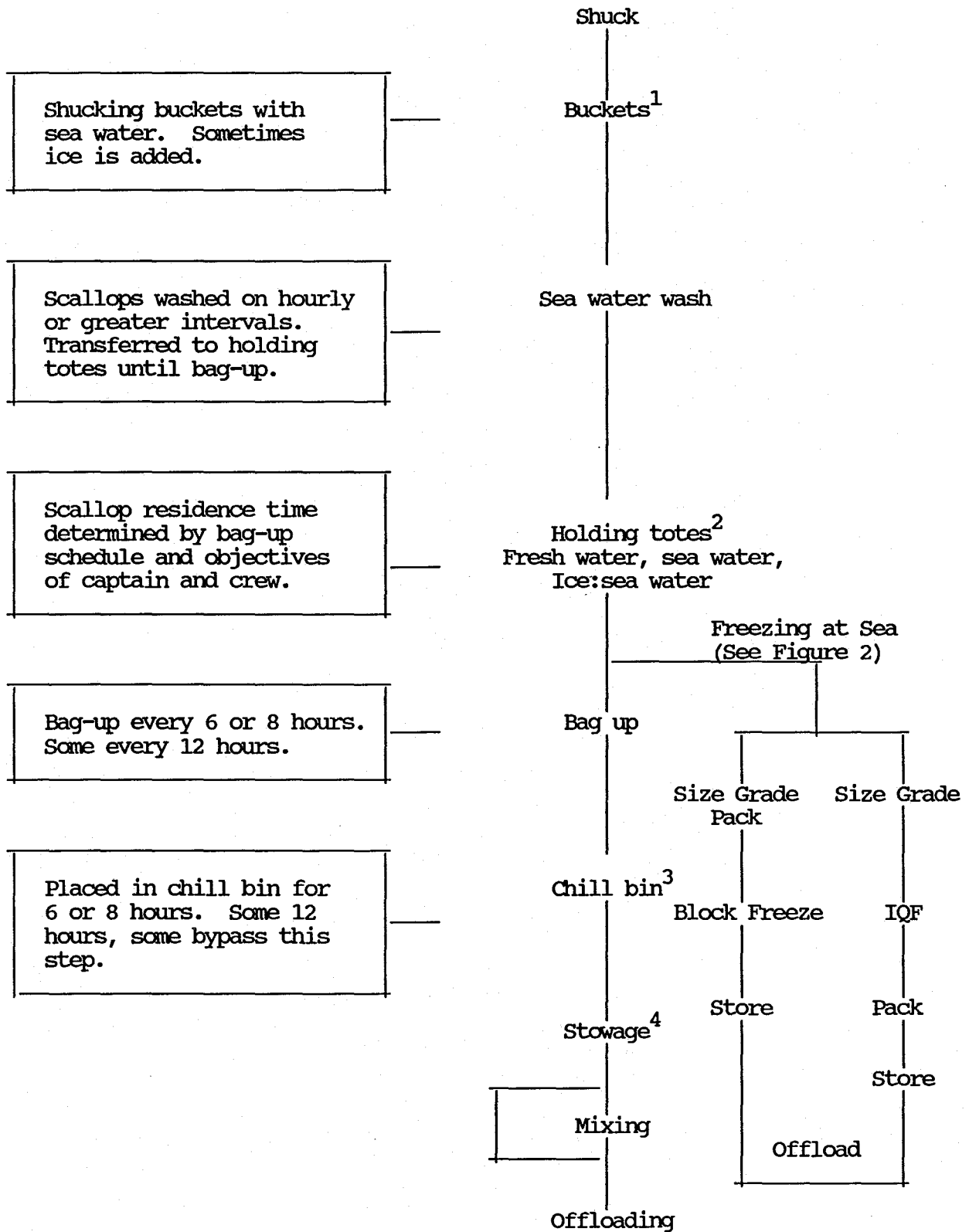

## Vessel Operations

1. During summer months, crew members often put ice or ice:seawater into their shucking buckets to keep scallops cool. Weight gains depend upon the amount of ice and residence time.

Weight gain: 2-3%.

2. Holding totes or wash bins are used to hold scallop meats until bag-up. Ice and seawater of various ratios or ice and fresh water are used to keep scallops cold. Weight gains depend upon amount of ice used in conjunction with seawater, whether or not fresh water is used and residence time.

Weight gain: Freshwater 6-22%; Weight gain: Ice and Seawater 3-13%

3. Bags of scallops are often placed in "chill bins" to cool for 6-12 hours before permanent stowage.

Weight gain: 0-1%

4. Scallop bags are stowed for the duration of the trip. Weight gains are the result of ice melt water being absorbed by scallop meats. Weight gains depend upon deck treatment, season, fishing areas, length of stowage, size of scallops, etc.

Weight gain: 2-12%



Figure 2. Sea Scallops Process Flowchart  
Shoreside Processing

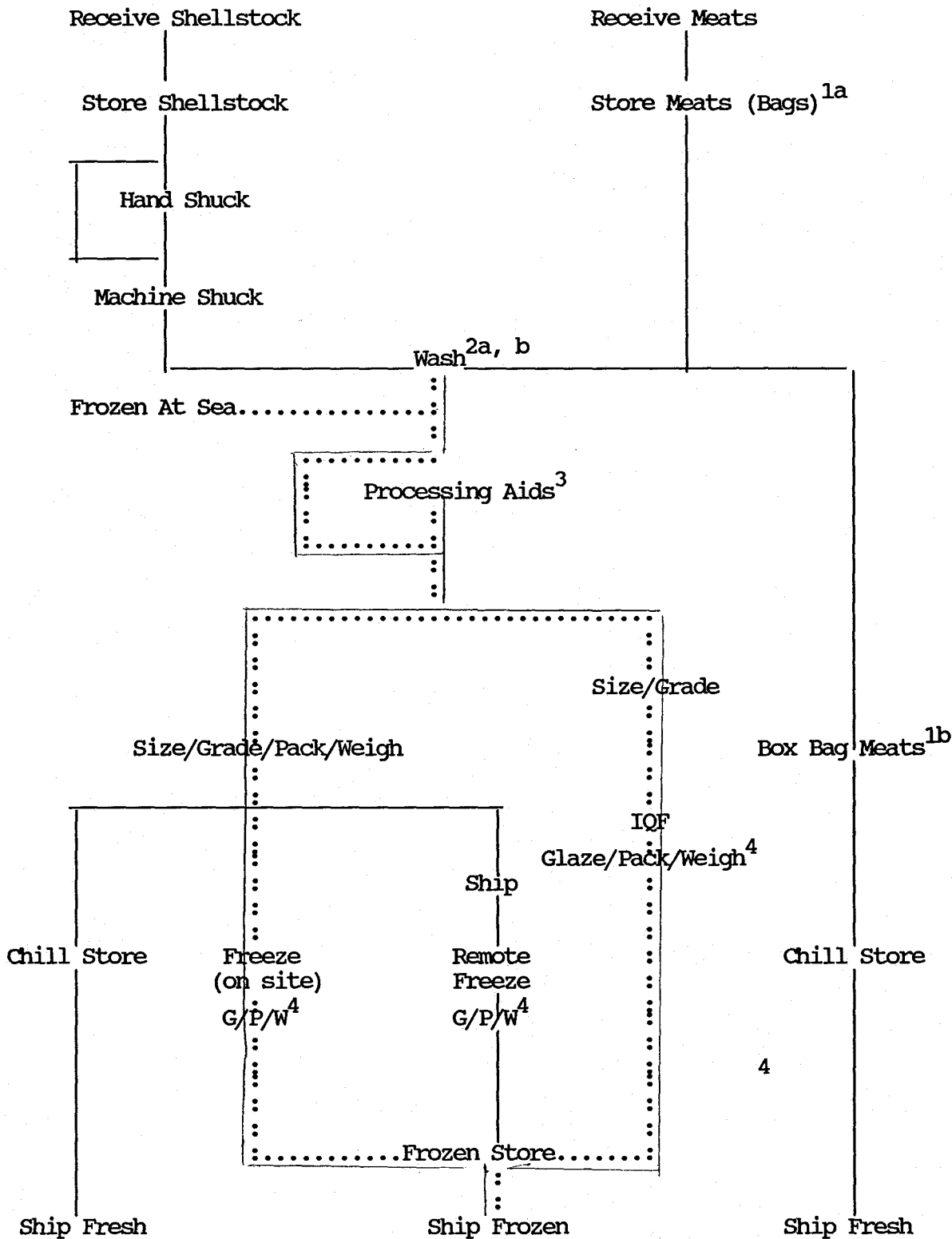

## Processing

1a-b. Bags of scallops are often transported in "fish" boxes packed with ice. Weight gain is the result of ice melt water absorbed by scallops and is dependent upon time of storage and degree of ice melt.

Weight gain: 0-2%.

2a. After shellstock scallops are shucked, scallop meats are washed, preferably in an agitator or bubble washer. Weight is dependent on quality of the shellstock, season, size of scallop meats and the duration of the wash.

Weight gain:	5 minute wash	2-6%
	10 minute wash	2-10%
	15 minute wash	4-12%
	30 minute wash	6-14%

2b. Bagged scallops are often washed prior to sorting, packing, shipping or freezing. If no further processing is intended, weight gains are dependent upon age and quality of scallops, season, size and residence time.

Weight gain: 0-4%

3. The use of processing aids either in a dip or static soak application can result in weight gains depending on the ionic strength of the medium, duration and type of application, quality and age of scallops, season and previous handling procedures (i.e. vessel deck treatments).

Weight gain:	Anti-Micro Agent (dip)	0-2%
	Phosphate (dip)	1-4%
	Phosphate (soak)	4-30%

4. The application of glazing for freezing can also add weight but the effect appears to be minimal.

Weight gain: Glazing 0-2%

# Calculated percent moisture conditional on weight increase

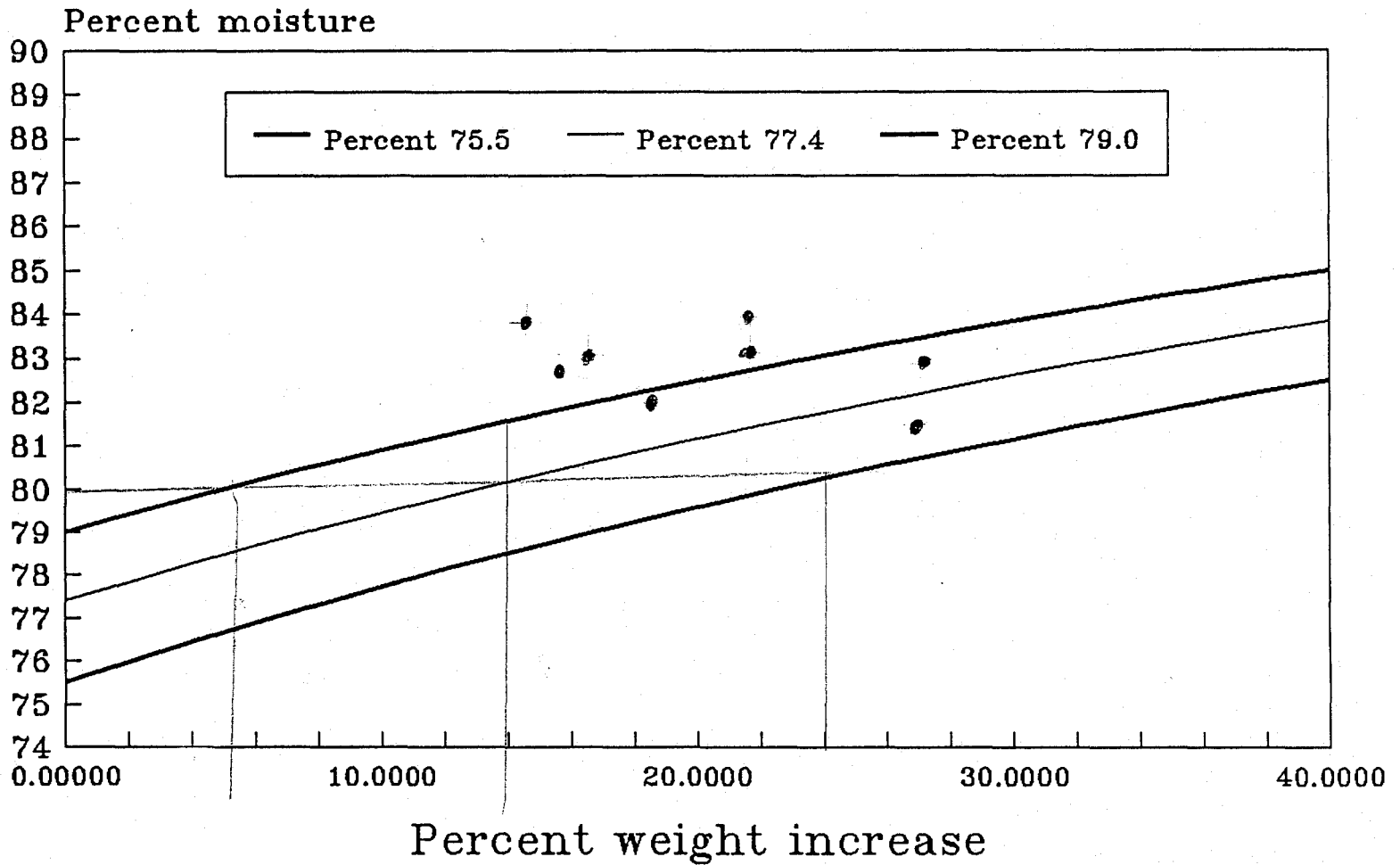

Appendix 2

DRAFT -- NOT TO BE CITED NOR REPRINTED  
WITHOUT PERMISSION OF THE AUTHORS

GOOD MANUFACTURING PRACTICES FOR THE  
HARVESTING AND PROCESSING OF  
SEA SCALLOPS (Placopecten magellanicus)

William DuPaul  
Robert Fisher  
Virginia Sea Grant Marine Advisory Program  
Virginia Institute of Marine Science  
College of William and Mary

and

Thomas Rippen  
Virginia Sea Grant Extension Program  
Virginia Polytechnic Institute and State University

Submitted to

Sea Scallop Task Force  
National Fisheries Institute

April 15, 1992

Virginia Marine Resource Report No. 92-2

## INTRODUCTION

The following are a draft set of good manufacturing practices (GMP) for the handling and processing of the Atlantic sea scallop, Placopecten magellanicus. The GMPs described here relate to the general objective for the production of good quality and wholesome seafood. More specifically, they relate to the uptake of water with subsequent gains in weight as a result of handling and processing on vessels and shoreside facilities. In part GMPs are derived from existing industry procedures and practices, and in recognition of the limitations to change existing practices without adversely impacting the economic and social structure of the industry.

It is important to recognize that there is a significant amount of variability in the research data due to the natural variability of the scallop. A host of biological and physical parameters effect how scallops "perform" relative to handling and processing practices. At this point we can only point to upper limits in changes in moisture that our limited data has revealed.

Of ultimate importance is the question relative to the natural moisture content of sea scallops. Needless to say that this too has a good deal of variability ranging from the extremes of about 75 to 79% but most of the data indicates that a "good average" is about 77.5% moisture. For the purpose of this draft document, the above mentioned average of 77.5% moisture is considered as the starting point at the time of harvesting.

The data presented in this document relative to the use of processing aids relate to the condensed phosphate, sodium tripolyphosphate (STP). However other phosphate types and commercial blends may result in different values for moisture content and retention.

SCALLOP DREDGE VESSELS  
SCALLOP NET VESSELS

PRACTICE:

Shucking buckets with seawater, sometimes ice is added.

RATIONAL:

Scallops must be kept chilled to prevent thermal abuse (wafering, rigor, unctinal properties) when water temperatures exceed 65 degrees F. Water in shucking buckets prevents entrapment of grit and sand into meat.

PRACTICE:

Scallops from shucking buckets are washed in seawater between haul-backs.

RATIONAL:

Washing is the only way to remove grit and sand. Frequent emptying of shucking buckets prevents thermal abuse during warm weather.

---

FINDINGS:

Practices can cause an increase in weight due to the incorporation of water not to exceed 2%.

PRACTICE:

After washing in seawater, scallops meats are transferred to insulated totes with removable covers. Totes should contain seawater and ice to a ratio not to exceed 2:1 when seawater temperatures are greater than 65 degrees F. Less ice could be used when seawater temperatures are below 65 degrees F.

RATIONAL:

Use of insulated totes minimizes ice melt. Ice is used to prevent thermal abuse. Seawater:ice slurry is used to insure maximize efficient chilling and prevent physical damage to scallop meats.

PRACTICE:

Totes emptied every six hours to bag scallops.

RATIONAL:

Longer time intervals may allow temperatures in totes to increase to unacceptable levels and cause unnecessary weight gains.

-----  
FINDINGS:

Use of insulated totes with seawater:ice (2:1) will cause weight gains associated with the degree or extent of ice melting in tote. Weight gains are variable depending upon biological parameters such as season and reproductive cycle, location of harvest, residence time in the tote and degree of ice melt. Ice melt is variable due to initial seawater temperature, deck temperatures, quality and integrity of the insulated totes, and the amount of scallops harvested. Up to 13% gain has been experienced under extreme conditions with seawater temperatures at or above 80 degrees F and deck temperatures exceeding 90 degrees F. Under average conditions and the use of a 2:1 seawater:ice slurry, weight gains would not be expected to exceed 10%.



**PRACTICE:**

After bagging, bags are rinsed with seawater and placed in chill bin covered with ice for six hours. This should coincide with bag-up schedule.

**RATIONAL:**

Efficient of pre-chilling of bags before permanent stowage is necessary to prevent excessive melting of ice during permanent stowage which creates air spaces around bags.

---

**FINDINGS:**

Permanent stowage of unchilled or unadequately chilled bags causes air pockets to develop around bags and which provide conditions which may lead to bacterial growth and discoloration of bags. Weight gain not to exceed 1%.

PRACTICE:

After pre-chilling, bags of scallops are cleaned with clean seawater and a nylon bristle brush.

RATIONAL:

Cleaning the surface of the bags removes debris and scallop exudate.

---

FINDINGS:

Weight gains not to exceed 0%.

PRACTICE:

Bags permanently stowed on a sufficient bed of ice, with placement of bags allowing adequate space for ice in between and around bags.

RATIONAL:

Bags must be adequately iced and sufficiently cooled to prevent spoilage and retard bacterial growth and maintain product quality. A degree of ice melt is important to insure adequate and continued cooling of scallop bags during stowage. Normal ice melt can be beneficial in the rinsing of bags and removal of bacteria.

---

FINDINGS:

Weight gain of scallop in bags during stowage is variable. Biological factors include season, state of reproduction and size of scallop meat. Other factors include area of harvest, time of stowage, temperature of ice hold, and the degree of weight gain associated with deck treatment. Weight gain not to exceed 6% when scallops are chilled on deck with a 2:1 seawater:ice slurry. When scallops are not chilled on deck, weight gains during stowage can range from 6-10% and should not exceed 12%.

PRACTICE:

Bags should be broken-out of ice stowage just prior to offloading.  
Bags should not be rinsed and exposed to warm temperatures.

RATIONAL:

Additional handling is unnecessary. It may cause product damage and additional weight gains.

---

FINDINGS:

Weight gains not to exceed 0%.

COMMENTS:

Weight gains reported here for vessel handling practices are not additive and should not be considered as a target value at offloading. Weight gains at one particular practice will effect weight gains for subsequent practices. Consequently, based on experimental data % weight gain for vessels should not exceed 13%. This, in general, corresponds to a landed product on average for the total catch, not exceeding 80% moisture. However, more work is needed to expand the database fully to justify a landed % moisture level in scallops that could serve as a level for compliance and/or establishing baseline data.

## OFFLOADING AND TRANSPORTATION

### PRACTICE:

After offloading, bags of scallops if held or transported prior to processing, should be packed in ice in a container that provides proper drainage of ice melt.

### RATIONAL:

Scallops should be kept cooled to maintain proper temperature and minimize unnecessary weight gains from melting ice.

---

### FINDINGS:

Estimates of weight gain for this practice has not been determined. Weight gains are dependent upon length of stowage and degree of ice melt. Weight gain should not exceed 2%.

## SHORESIDE PROCESSING

### PRACTICE:

Practice for washing scallop meats.

#### A. Chilled freshwater

Scallops meats should be placed in chilled (less than or equal to 45 degrees F) potable freshwater. Scallops should be mechanically (air) or manually (paddle) agitated not to exceed 20 minutes. Scallop meats should be immediately drained, graded and packed.

### RATIONAL:

It is necessary to thoroughly wash scallop meats to remove any remaining shell fragments, grit and sand. Additionally scallops have to be washed to separate meats for grading and packing. Washing appears to be the most effective method for separating meats to prevent physical damage.

-----

### FINDINGS:

Weight gains for washing are variable and depend upon weight gains from previous handling practices. Preliminary data indicated that weight gains should not exceed 4%. However, more data is needed for washing practices to fully document final weight changes.

### COMMENTS:

In the contents of this exercise, this practice (washing) is considered to produce a final product<sup>2</sup> ready for market. No further washing or processing is anticipated. However, experience has demonstrated that this practice does not always result in a superior or desired product according to organoleptic evaluations. In general, this corresponds to a scallop with a moisture content not to exceed 81% on average based on a landed product of 80% moisture. However, if product has been held or transported packed in ice moisture content should not exceed 81.5% on average.

---

1. This statement does not apply to the application of STP or other processing aids by the use of dips with a duration not to exceed two minutes.

2. When scallops are to be IQF processed, it is reasonable to expect additional increases in moisture not to exceed 1%.

PRACTICE:

Practice for washing scallop meats.

B. Chilled Brine (3%)

Scallops meats should be placed in chilled (less than or equal to 45 degrees F) brine. Brine should be made from potable freshwater and food grade salt. Scallops should be mechanically (air) or manually (paddle) agitated not to exceed 20 minutes. Scallop meats should be immediately drained, graded and packed.

RATIONAL:

It is necessary to thoroughly wash scallop meats to remove any remaining shell fragments, grit and sand. Additionally scallops have to be washed to separate meats for grading and packing. Washing appears to be the most effective method for separating meats to prevent physical damage.

-----  
FINDINGS:

Weight gains for washing are variable and depend upon weight gains from previous handling practices. Preliminary data indicated that weight gains should not exceed 0% (+1%). It is also possible that scallops could have a net weight loss after washing with 3% brine. However, more data is needed for washing practices to fully document final weight changes.

COMMENTS:

In the contents of this exercise, this practice (washing) is considered to produce a final product<sup>2</sup> ready for market.<sup>1</sup> No further washing or processing is anticipated. However, experience has demonstrated that this practice may change the flavor profile slightly and/or organoleptic evaluations. In general, this corresponds to a scallop with a moisture content not to exceed 80% on average based on a landed product of 80% moisture. However, if product has been held or transported packed in ice moisture content should not exceed 80.5% on average.

---

1. This statement does not apply to the application of STP or other processing aids by the use of dips with a duration not to exceed two minutes.

2. When scallops are to be IQF processed, it is reasonable to expect additional increases in moisture not to exceed 1%.

PRACTICE:

Practice for washing scallop meats.

C. Sodium tripolyphosphates (STP)

Scallops meats should be placed in chilled (less than or equal to 45 degrees F) STP solution. Solution should be made from portable freshwater and food grade STP at a concentration of 4-6% by weight. Scallops should be mechanically (air) or manually (paddle) agitated not to exceed 20 minutes. Scallop meats should be immediately drained, graded and packed.

RATIONAL:

It is necessary to thoroughly wash scallop meats to remove any remaining shell fragments, grit and sand. Additionally scallops have to be washed to separate meats for grading and packing. Washing appears to be the most effective method for separating meats to prevent physical damage. Phosphates, as a processing aid, have been demonstrated to improve product quality when properly applied. Quality attributes can be extended fresh shelflife, moisture retention (fresh and frozen), lower bacterial counts, color, odor and improved texture of raw and cooked product.

-----  
FINDINGS:

Weight gains for washing are variable and depend upon weight gains from previous handling practices and concentrations of STP. Preliminary data indicated that weight gains achieved in phosphate solutions are typically smaller than those achieved in freshwater washes. Research data has indicated that weight gains should not exceed 3% when using 6% by weight solution of STP. Quality attributes of phosphate use can be the extension of fresh shelflife, moisture retention (fresh and frozen), lower bacterial counts, color, odor and improved texture of raw and cooked product.



COMMENTS:

In the contents of this exercise, this practice (processing) is considered to produce a final product<sup>1</sup> ready for market. No further washing or processing is anticipated.<sup>2</sup> The optimum STP concentration is not precisely known but the data indicates that it may be between 4-6% and weight gains may vary accordingly. Lower concentrations may result in greater weight gains but concomitant decreases in moisture retention. Concerns of higher concentrations relates to unacceptable residual phosphate levels. Other forms of phosphates as processing aids may give different results. More data is needed to determine optimum concentrations of phosphates as processing aids in a washing operation. In general, this corresponds to a scallop with a moisture content not to exceed 81% on average based on a landed product of 80% moisture. However, if product has been held or transported packed in ice moisture content should not exceed 81.5% on average.

---

1. This statement does not apply to the application of STP or other processing aids by the use of dips with a duration not to exceed two minutes.

2. When scallops are to be IQF processed, it is reasonable to expect additional increases in moisture not to exceed 1%.

PRACTICE:

Application of STP as a dip.

The application of STP as a dip should follow the prescribed practice for washing in either freshwater or brine solution. Dipping solutions containing STP at a concentration of 8-10% by weight is recommended in combination with a dwell time not to exceed two minutes. After dipping scallops are drained, graded and packed.

RATIONALE:

It is necessary to proceed above practice with the described washing practice to remove shell fragments, grit and sand. Washing appears to be the most effective method for separating meats to prevent physical damage and to allow proper contact with phosphate medium. Phosphates as a processing aid have been demonstrated to improve product quality when properly applied. Quality attributes can be extended fresh shelflife moisture retention (fresh and frozen), lower bacterial counts, color, odor and improved texture raw and cooked product.

-----  
FINDINGS:

Weight gain for the practice of dipping are variable and depend upon weight gains from previous handling and washing practices. Preliminary data indicated that weight gains achieved in phosphate solutions are in the range of 2-3%. Weight gains are affected by concentrations of STP used in the dipping solution and dwell time. STP concentrations above 10% may result in residual added levels of phosphate to exceed 0.5%.

COMMENTS:

The contents of this practice (the use of STP as a dip) is considered to produce a final product ready for market no further washing or processing is anticipated. In general, this corresponds to a scallop with a moisture content not to exceed 81.5% on average (freshwater wash) or 80.5% on average (brine wash) based on a landed product of 80% moisture. However, if product has been held or transported in ice, moisture content should not exceed 82% and 81% on average respectively.

PRACTICE:

Practice for processing scallop meats with sodium tripolyphosphate (STP)

A. Processing

Bags of scallops are emptied into a chilled (less than 45 degrees F) solution of 2-4% by weight food grade STP or other phosphate compounds and commercial blends. Salt (NaCl 1% by weight) may be added to processing solution. Scallops and processing solution should be agitated periodically and held at or below 45 degrees F and for periods of three to six hours. After processing scallops should be drained, graded and packed.

RATIONALE:

Processing scallops in solutions of STP or other phosphate compounds has been demonstrated to improve product quality when properly applied. Longer exposure times (greater than 20 minutes) and at recommended concentrations have improved sensory and functional attributes during fresh and frozen storage. Salt and conjunction with STP has shown to have beneficial synergistic effects. Cold processing temperatures minimize bacterial growth. Longer processing times with low concentrations of STP may permit more uniform distribution of STP and therefore provide for a more consistent processing result.

## FINDINGS:

Data has shown that properly controlled processing with STP\* (when compared against unprocessed or processed with water) scallop quality attributes are improved. For fresh products these include:

- improved sensory attributes (raw appearance and odor; cooked odor, flavor and texture);
- decreased drip and cooked water loss;
- extension of fresh shelf life; and
- lower aerobic plate counts.

For frozen products improved quality attributes include:

- improved sensory attributes (thaw appearance and odor; cooked odor, flavor and texture);
- decreased thaw drip and cooked water loss; and
- extension of frozen storage (STP as a cryoprotectant).

Use of 1% NaCl in processing (2-4% STP) solution has been shown to decrease the amount of thaw and cooked drip loss obviating the need for higher concentrations of STP\*.

The use of 2-4% STP solution for the prescribed processing times (2-4 hrs.) have been shown to result in residual levels of added phosphates less than 0.5%. Lower concentrations of STP result in excessive water weight gains and reduces the functional attributes as described above.

Higher concentrations of STP (greater than 4%) have been shown to impart unfavorable characteristics to appearance, flavor and texture. Residual levels of added phosphate may exceed 0.5%.

Data has shown that processing times of two to six hours are sufficient to allow adequate incorporation of STP without excessive hydration and results in improved functional and sensory attributes as described above.

Weight gains for processing and STP are variable and depend upon the weight gains from previously handling practices. Data has shown that as processed above weight gain in scallops range from 4-12%.

COMMENTS:

Weight gains as a result of processing are highly variable and depend upon weight gains from previous handling practices, biological and environmental parameters. In the context of this exercise this practice (processing) is considered to produce a final product<sup>2</sup> ready for market.<sup>1</sup> No further washing or processing is anticipated.

The optimum STP concentration is not precisely known for this application but the data indicates that it may be between 2-4%. Other forms of phosphates as processing aids may give different results. Also, the mode of application (e.g. soak, vacuum/tumbling, dips), needs further comparative evaluations. More work is needed on the organoleptic evaluation and consumer acceptability relative to the use of phosphates or other processing aids inclusive of method of application.

In general, this practice should result in scallops with a moisture content not to exceed 83% on average based on a landed product of 80% moisture.

---

1. This statement does not apply to the application of STP or other processing aids by the use of dips with a duration not to exceed two minutes.

2. When scallops are to be IQF processed, it is reasonable to expect additional increases in moisture not to exceed 1%.

## SCALLOP SHELLSTOCK

### PRACTICE:

Scallops after culling are placed in vessel ice hold. Ice is mixed or layered with scallops for stowage to insure proper chilling.

### RATIONALE:

Ice is used to prevent product deterioration during the length of the fishing trip.

### FINDINGS:

No data is available on weight (moisture) changes associated with shellstock stowage.

PRACTICE:

Offloading and shucking of scallop shellstock

Scallops shellstock is offloaded into refrigerated holding areas prior to shucking. Scallops are shucked, weighed, washed, graded and packed. The practice for washing shucked scallops in chilled freshwater, chilled brine and chilled sodium tripolyphosphate solution is the same in previous sections on washing.

RATIONALE:

It is necessarily to thoroughly wash scallop meats to remove any shell fragments, grit and sand prior to grading and packing. Additionally, the use of STP as a processing aid has been demonstrated to improve product quality when properly applied. Quality attributes can be extended shelve life, moisture retention (fresh and frozen), lower bacterial counts, color, odor and improved texture of raw and cooked product.

-----  
FINDINGS:

A. Chilled freshwater

Weight gains for washing are variable and depend upon biological and environmental parameters, size of scallop meat, quality of the landed shellstock and the natural moisture content of the scallop. Preliminary data indicates that weight gain should not exceed 6%.

COMMENTS:

In the context of this practice,<sup>1</sup> (washing) is considered to produce a final product ready for market. No further washing or processing is anticipated.<sup>2</sup> In general, this corresponds to a scallop with a moisture content not to exceed 80% on average. However, the degree of moisture increase during vessel stowage of shellstock is unknown. More research is needed in this area to set levels of compliance.

B. Chilled brine

Weight gains for washing are variable and depend upon biological and environmental parameters, size of scallop meat, quality of the landed shellstock and the natural moisture content of the scallop. Preliminary data indicates that weight gain should not exceed 1%.

COMMENTS:

In the contents of this exercise, this practice (washing) is considered to produce a final product<sup>1</sup> ready for market. No further washing or processing is anticipated.<sup>2</sup> However, experience has demonstrated that this practice may change the flavor profile and/or organoleptic evaluations due to increased salt content. In general, this corresponds to a scallop moisture content not to exceed 79%.

C. Sodium tripolyphosphate

Weight gains for washing are variable and depend upon biological and environmental parameters, size of scallop meat, quality of the landed shellstock and the natural moisture content of the scallop. Preliminary data indicates that weight gains achieved in phosphate solution are typically smaller than those achieved in freshwater washes research data has indicated that weight gains should not exceed 4%.

COMMENTS:

In the contents of this exercise (washing) is considered to produce a final product<sup>1</sup> ready for market. No further washing or processing is anticipated.<sup>2</sup> The optimum STP concentration is precisely known but data indicates that it may be between 4-6% and weight gains may vary accordingly. Lower concentrations may result in greater weight gains but concomitant decreases in moisture retention. Concerns of higher concentrations relates to unacceptable residual phosphate levels. Other forms of phosphates as processing aids may give different results. More data is needed to determine optimum concentrations of phosphates as processing aids in a washing operation. In general, this corresponds to a scallop with a moisture content not to exceed 80% on average. However, the degree of moisture increase during vessel stowage of shellstock is unknown. More research is needed in this area to set level of compliance.

---

1. This statement does not apply to the application of STP or other processing aids by the use of dips with a duration not to exceed two minutes.

2. When scallops are to be IQF processed, it is reasonable to expect additional increases in moisture not to exceed 1%.



PRACTICE:

Practice for processing scallop meats from shellstock operations with sodium tripolyphosphates (STP)

A. Processing

Shuck scallop meats are emptied into a chilled (less than 40 degrees) solution of 2-4% by weight food grade STP or other phosphate compounds and commercial blends. Salt (NaCl% by weight) may be added to processing solution. Scallops and processing solution should be agitated periodically and held at or below 40 degrees F and for periods of two to six hours. After processing scallops should be drained, graded and packed.

RATIONALE:

Processing scallops in solutions of STP or other phosphate compounds has been demonstrated to improve product quality when properly applied. Longer exposure times (greater than 20 minutes) and at recommended concentrations have improved sensory and functional attributes during fresh and frozen storage. Salt and conjunction with STP has shown to have beneficial synergistic effects. Cold processing temperatures minimize bacterial growth. Longer processing times with low concentrations of STP may permit more uniform distribution of STP and therefore provide for a more consistent processing result.

-----  
FINDINGS:

Data has shown that properly controlled processing with STP\* (when compared against unprocessed or processed with water) scallop quality attributes are improved. For fresh products these include:

- improved sensory attributes (raw appearance and odor; cooked odor, flavor and texture);
- decreased drip and cooked water loss;
- extension of fresh shelf life; and
- lower aerobic plate counts.

For frozen products improved quality attributes include:

- improved sensory attributes (thaw appearance and odor; cooked odor, flavor and texture);
- decreased thaw drip and cooked water loss; and
- extension of frozen storage (STP as a cryoprotectant).

Use of 1% NaCl in processing (2-4% STP) solution has been shown to decrease the amount of thaw and cooked drip loss obviating the need for higher concentrations of STP\*.

The use of 2-4% STP solution for the prescribed processing times (two to four hours) have been shown to result in residual levels of added phosphates less than 0.5%. Lower concentrations of STP result in excessive water weight gains and reduces the functional attributes as described above.

Higher concentrations of STP (greater than 4%) have been shown to impart unfavorable characteristics to appearance, flavor and texture. Residual levels of added phosphate may exceed 0.5%.

Data has shown that processing times of two to six hours are sufficient to allow adequate incorporation of STP without excessive hydration and results in improved functional and sensory attributes as described above.

Weight gains for processing and STP are variable and depend upon the weight gains from previously handling practices. Data has shown that as processed above weight gain in scallops range from 7-12%.

#### COMMENTS:

Weight gains as a result of processing are highly variable and depend upon weight gains from shellstock holding practices, biological and environmental parameters and the natural moisture content of the scallop. In the context of this exercise this practice (processing) is considered to produce a final product ready for market. No further washing or processing is anticipated.

The optimum STP concentration is not precisely known for this application but the data indicates that it may be between 2-4%. Other forms of phosphates as processing aids may give different results. Also, the mode of application (e.g. soak, vacuum/tumbling, dips), needs further comparative evaluations. More work is needed on the organoleptic evaluation and consumer acceptability relative to the use of phosphates or other processing aids inclusive of method of application.

In general, this practice should result in scallops with a moisture content not to exceed 81% on average.



Virginia Institute of Marine Science  
School of Marine Science

P. O. Box 1346  
Gloucester Point, Virginia 23062  
804/642-7000, Fax 804/642-7097, Scats 842-7000

August 3, 1992

Mr. E. Brian Veasy  
President, American Scallop Association  
P. O. Box 8933  
New Bedford, Massachusetts 02740

Dear Brian:

Attached is a revised protocol for the proposed evaluation of processed Atlantic sea scallops. We have taken into consideration the suggestions offered by FDA. Significant changes include:

1. The addition of another variable of processed scallops with less than 80% moisture.
2. Rather than evaluate just moisture content (MC on the previous flowchart), we will perform a proximate analysis (PA) in its place. This includes moisture, protein, ash, total carbon.
3. We will make the comparison on nutritional profiles (NP\*) for both raw and cooked products for shellstock, scallops when offloaded, and for both STP and fresh water 20 minute washes since these are considered as control points.

In addition, please note changes in the budget. The 10% contingency is the result of our discussions with IFAC.

Sincerely,

William D. DuPaul, Ph.D.  
Chairman, Department of  
Marine Advisory Services

WDD:cht

Enclosure

On behalf of:

Dr. Steve Otwell  
Dept. of Food Science  
& Human Nutrition  
University of Florida  
Gainesville, FL

Mr. Robert Fisher  
VA Sea Grant Marine  
Advisory Program  
VA Inst. of Marine Sci.  
Gloucester Point, VA

Mr. Thomas Rippen  
VA Sea Grant Marine  
Advisory Program  
VPI & SU Seafood Lab  
Hampton, VA



## AN EVALUATION OF PROCESSED ATLANTIC SEA SCALLOPS

The primary objective of the proposed research will be to evaluate organoleptic parameters, consumer preference, nutritional profiles and moisture retaining characteristics of Atlantic sea scallops processed with a condensed phosphate (sodium tripolyphosphate; STP). In order to properly evaluate STP processing, sea scallops must be obtained from a single source with a known history of harvesting and vessel handling procedures. Consequently, this study must begin at the fishing vessel and end with evaluations of consumer acceptance and shelflife determination. The complete sequence of harvesting, processing and evaluation must be performed within the context of the proposed guidelines for "processed sea scallops" with a final target moisture content clearly pre-determined (see flow chart).

Much of the background research work has already been completed. For example, sufficient information is available on the proper concentration of STP and processing times in order to meet residual phosphate and target tissue moisture content. These aspects of scallop processing were clearly detailed in the draft GMP document. The research proposal will concentrate on the aspects of consumer evaluation shelflife and nutritional profiles so that legitimate comparisons can be made between processed and unprocessed scallops.

### Vessel Operations

Scallops that will be used for the study will be obtained from a trip on a commercial scallop vessel from New Bedford, Massachusetts fishing on Georges Bank. Scallops from the 6th-7th day of the fishing trip will be selected for the study which represents about the mid-point of the trip. Consequently the scallops will be stowed on the vessel for 5-7 days before offloading and processing. Proximate analyses will be performed on scallops as they are harvested (live), at the time of bagging and stowage, and again at offloading. Bags of scallops will be tagged on the vessel to insure proper identification of scallops that will be used for the study.

### Consumer Evaluation (CE)

Consumer sensory panel studies will be performed to determine whether sea scallops that are washed versus processed can be differentiated based on acceptability and, if so, which of the treatment(s) is (are) most acceptable. The evaluation of approximately 125 judgements from a statistically valid pre-screened consumer profile will determine overall acceptability of cooked sea scallops and will summarize the evaluators' comments related to preference. This study will include a detailed, pre-tested questionnaire administered to consumers pre-screened for interest in scallops, age, sex, income, etc. Each consumer product evaluation time will involve over one hour experience with cooked products. An organoleptic evaluation team will administer, evaluate, statistically analyze and report the consumer responses. A full test kitchen and auditorium will be arranged for a professional, non-distracting evaluation setting. Five variables as identified in Figure 1 will be selected for consumer evaluation studies. Scallops from selected variables will be frozen and shipped to Gainesville, Florida.

### Organoleptic Evaluation (OE) and Shelf-life Determination (OS)

Fresh shelf-life studies will be conducted with a 10-15 member sensory panel utilizing 7-point hedonic scales for appearance, odor, flavor and texture. Treatments to be compared include scallops which are cut and bagged on-board, then washed and processed and shellstocked scallops cut shore-side and washed. The packaged meats from various treatments will be stored in ice and periodically evaluated organoleptically and for aerobic plate count. End of shelf-life for each treatment is considered to be any mean sensory score of 4 or below. On frozen samples, organoleptic evaluations (OE) will be conducted at 1, 3, 6 and 12 month intervals. In addition, residual phosphorus will be determined.

### Nutritional Profiles (NP)

Nutritional profiles will be performed on scallops at various stages in the processing protocol (Figure 1) as designated by NP. Seven variables are identified in the protocol for nutritional profiling with the following nutrients to be determined: protein, vitamin C, riboflavin, niacin, phosphorus, calcium, vitamin B (12), magnesium, zinc, copper and sodium. Analysis will be done in triplicate on a composite of 12 subsamples per variable on cooked scallops as in reference to 101.9 (c)(7) IV, CFR 21.

### Microbiological Testing (MO)

At each proposed sampling period, enumeration of total aerobic bacteria will be performed using Petrifilm<sup>TM</sup> aerobic count plates manufactured by 3M microbiology products, St. Paul, Minnesota. Sample homogenates will be prepared according to AOAC method 966.23B, 15th ed., with serial dilutions of  $10^{-3}$  through  $10^{-7}$  duplicate plated on dry-film plates according to Petrifilm<sup>TM</sup> prescribed procedures. Plates will be incubated at  $35 \pm 1^{\circ}\text{C}$  for  $48 \pm 3$  hours. Enumerations will be made on plates with 30-300 colonies per plate, and recorded as colony forming units per gram (CFU/g) and log CFU/g.

### Proximate Analysis (PA)

Proximate analysis includes percent moisture, protein, ash and total carbon.

# SCALLOP PROCESSING PROTOCOL FLOW DIAGRAM

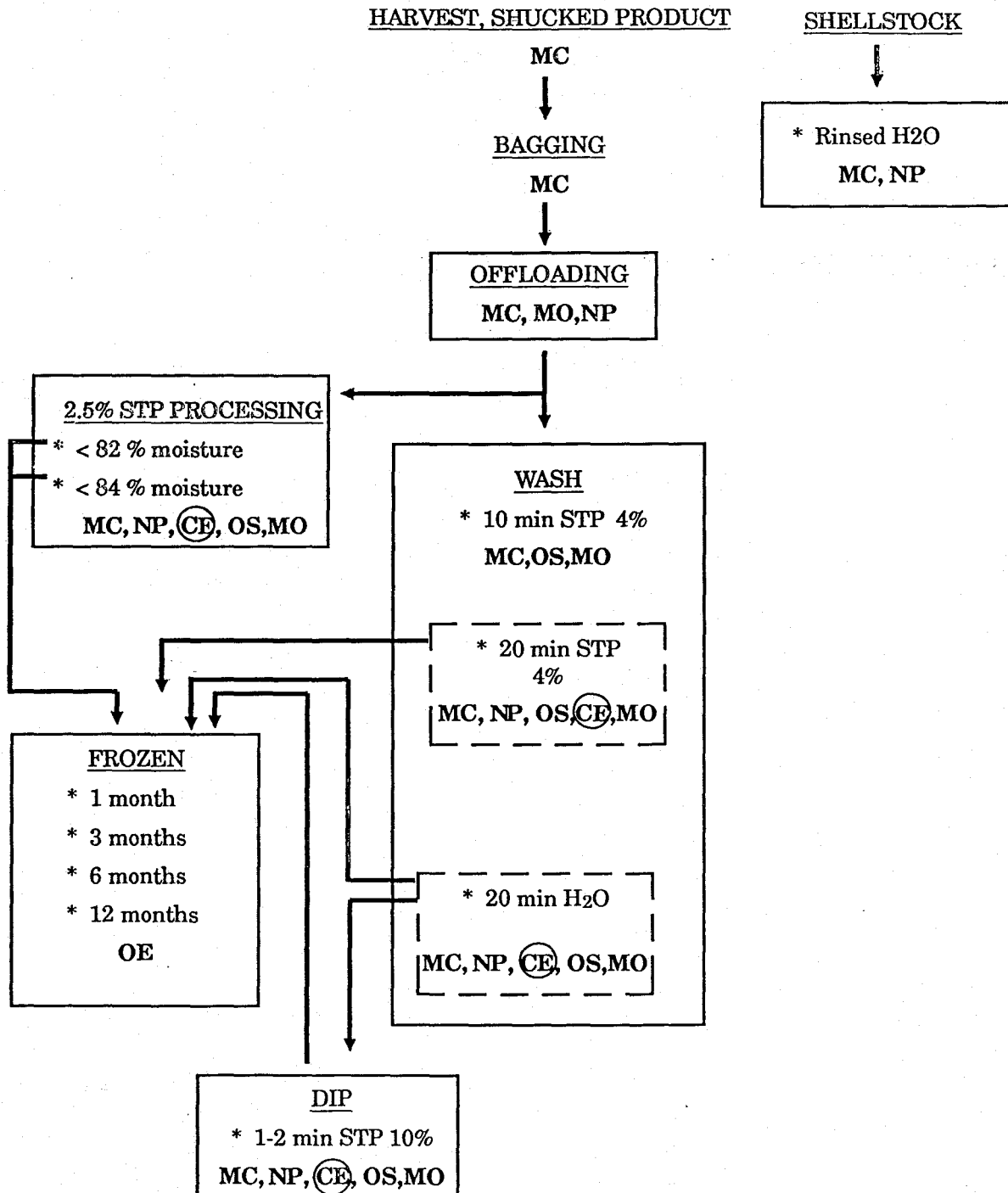

MC = Moisture Content

NP = Nutrition Profile

OS = Organoleptic Evaluation Shelf Life \*

MO = Microbiological Evaluation

CE = Consumer Evaluation (frozen)

OE = Organoleptic Evaluation

## Appendix 4

Analytical methods used by the Virginia Institute of Marine Science Nutrient Analysis Laboratory for proximate analysis.

<u>Component</u>	<u>Procedure</u>
Moisture	AOAC 950.46 Chapter 39:931
Protein	Carlo Erba Strumentazione Nitrogen* Analyzer 1500 instruction manual, 1986. (% Protein = % N x 6.25)
Ash	AOAC 900.02A Chapter 39:947
Total Carbon	Carlo Erba Strumentazione Carbon/Nitrogen Analyzer 1500 instruction manual, 1986.

\* Haake Buchler Instruments and Co./FISON  
15300 Rotundra Drive  
Suite 306  
Deerborn, Michigan 48120

## Appendix 5

Nutritional equivalency methodology references used by ABC Research Corporation.

<u>Component</u>	<u>Procedure</u>
Moisture	AOAC 950.46 Chapter 39:931*
Protein	AOAC 981.10 Chapter 39:937
Ash	AOAC 900.02 A Chapter 39:947
Minerals	Atomic Absorption
Calcium	
Copper	
Zinc	
Magnesium	
Sodium	
Phosphorus	USDA Chem Lab Guidebook 3.009
Vitamins	
Vitamin A	AOAC 974.29 Chapter 45:1045
Vitamin B <sub>12</sub>	Methods of Vitamin Assay, 4th Ed., (1985), p. 497-514.
Vitamin C	AOAC 967.21 Chapter 45:1058
Niacin	Methods of Vitamin Assay, 4th Ed., (1984), p. 385-398.
Riboflavin	AOAC 940.33 Chapter 45:1086

\* AOAC Procedures are all from the 15th Edition of the Official Methods of Analysis of the Association of Official Analytical Chemists, 1990. AOAC, Arlington, VA.



Appendix 6

**Shelflife Extension and Weight Retention of Sea Scallops Treated with Sodium Tripolyphosphate, With and Without Dissolved Carbon Dioxide**

Rippen, T., H. Sutton, L. Lampila, C. Hackney and R. Lane

1990

Virginia Polytechnic Institute and State University

The following set of figures summarize the results of a study using solutions of sodium tripolyphosphate and dissolved CO<sub>2</sub> for pretreating sea scallops. The fresh shelflife study was conducted on scallops held in the solutions for 20 hours prior to iced storage. The others are labeled either 20 hours or 2 hours. The phosphate distribution figures compare phosphate content in the interior of the scallops with that on the outer 3-5 mm of the exterior surface. Each study was duplicated or triplicated. In general, major differences in the data were significant ( $p < 0.05$ ).

Sodium tripolyphosphate did reduce drip losses as expected, with exposure to three percent solutions for two hours producing no net gain or loss upon thawing. Tripolyphosphate also improved the microbial and sensory quality of fresh scallops during iced storage. The dashed horizontal line on each sensory figure was considered the end of shelflife. The phosphate effectiveness was proportional to the concentration of phosphate used. The studies suggest that dissolved CO<sub>2</sub> has no beneficial effect on phosphate uptake, yields or fresh shelflife.

# Raw appearance scores

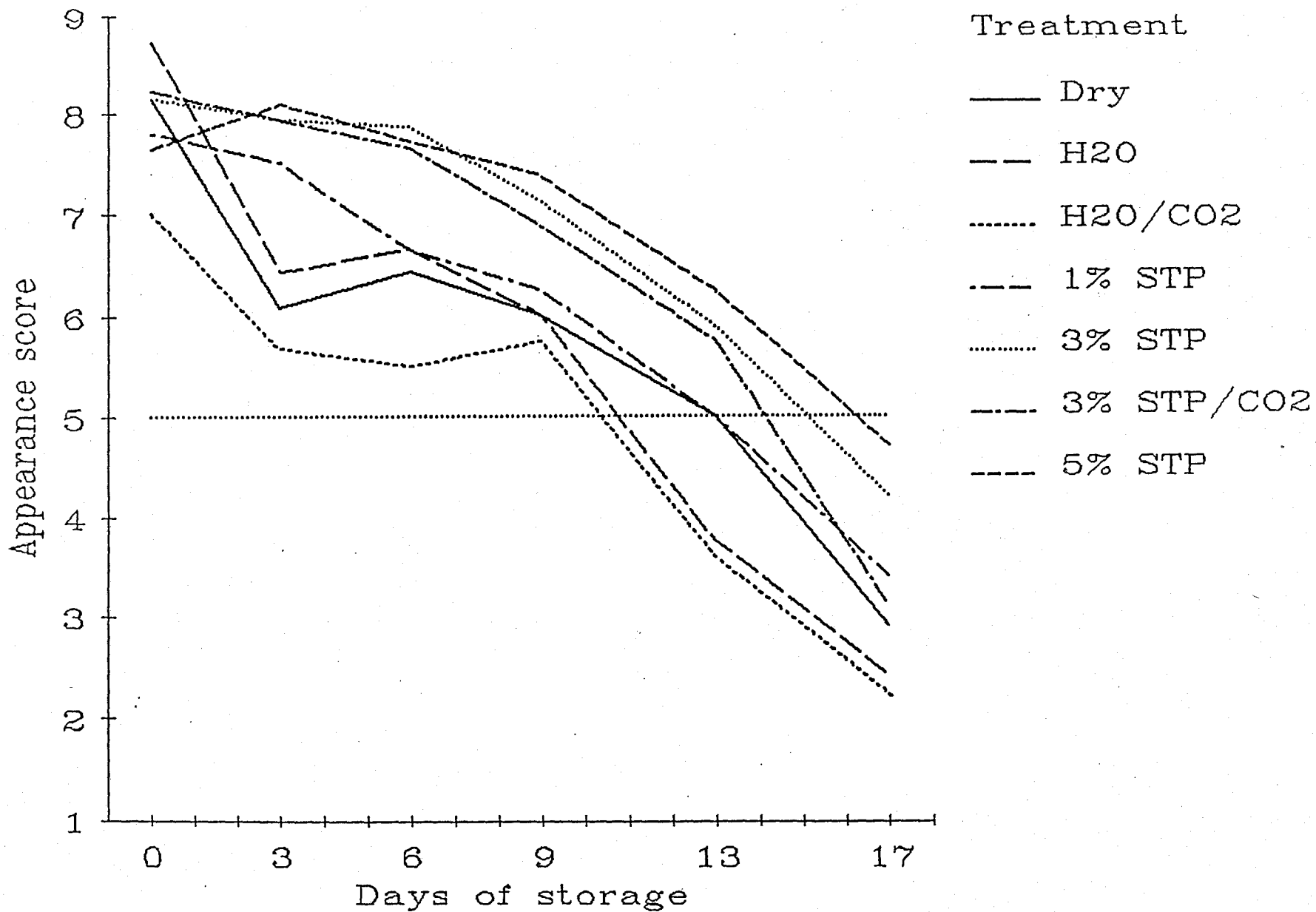

# Raw odor scores

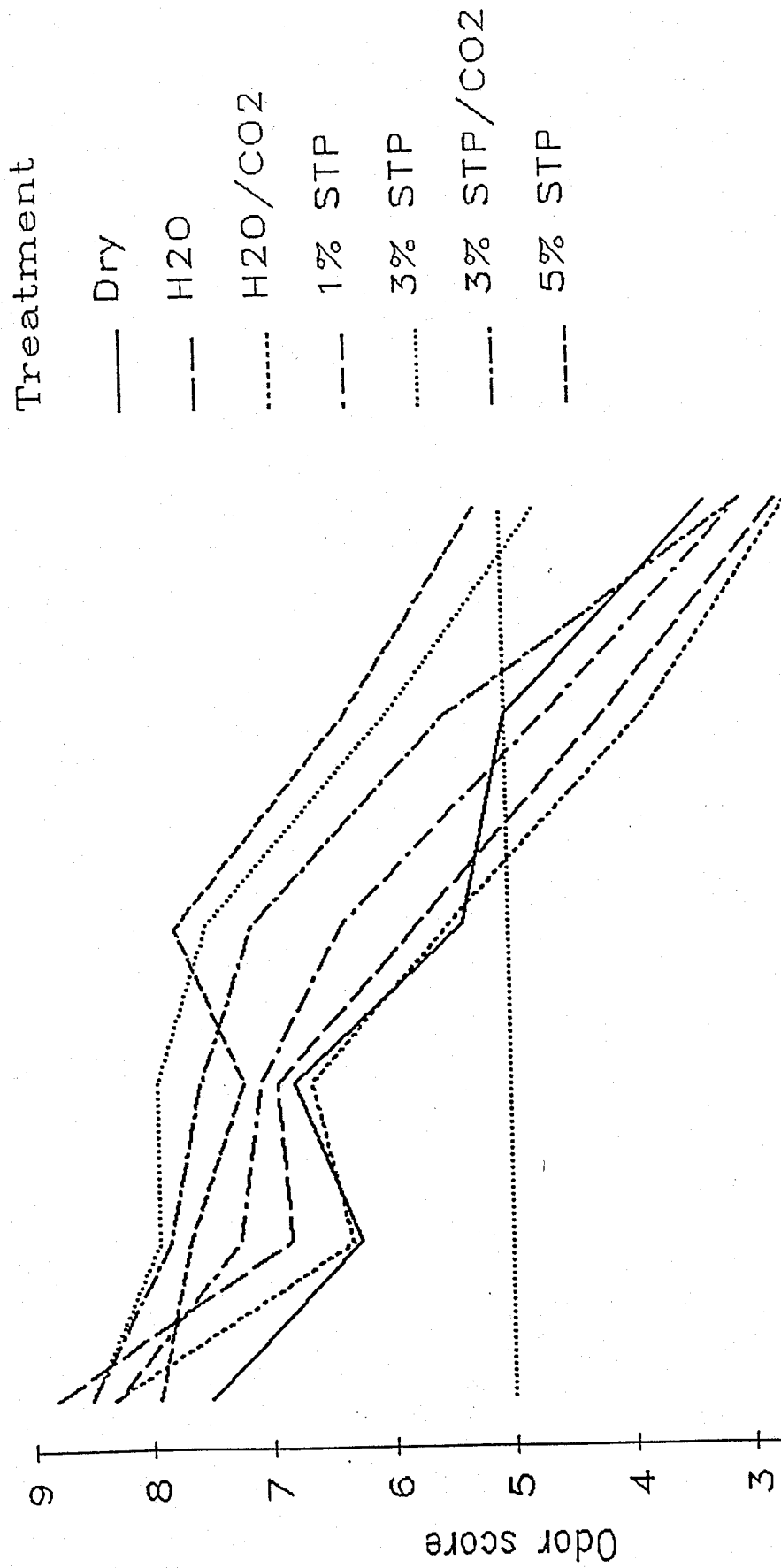

# Cooked appearance scores

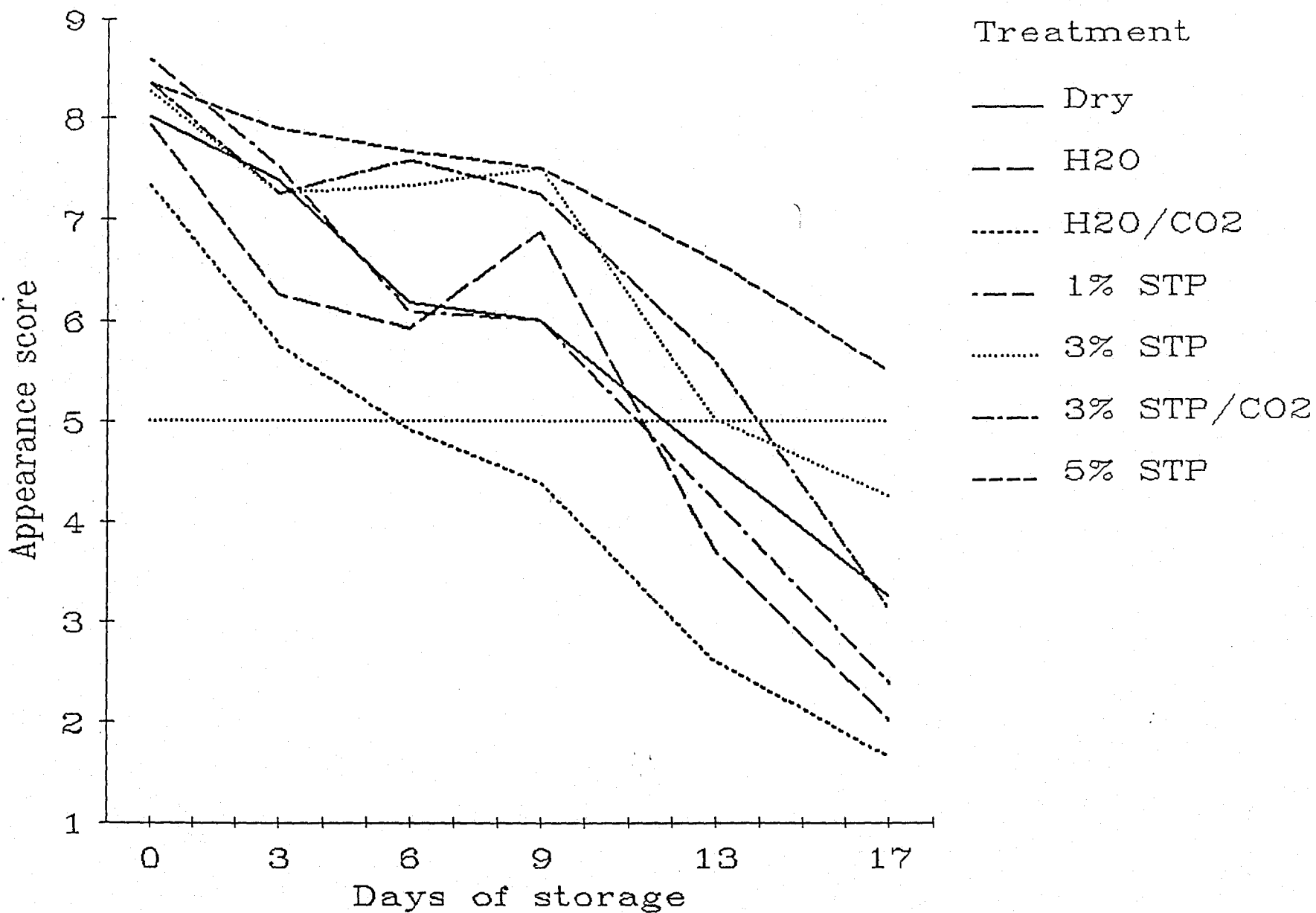

# Cooked odor scores

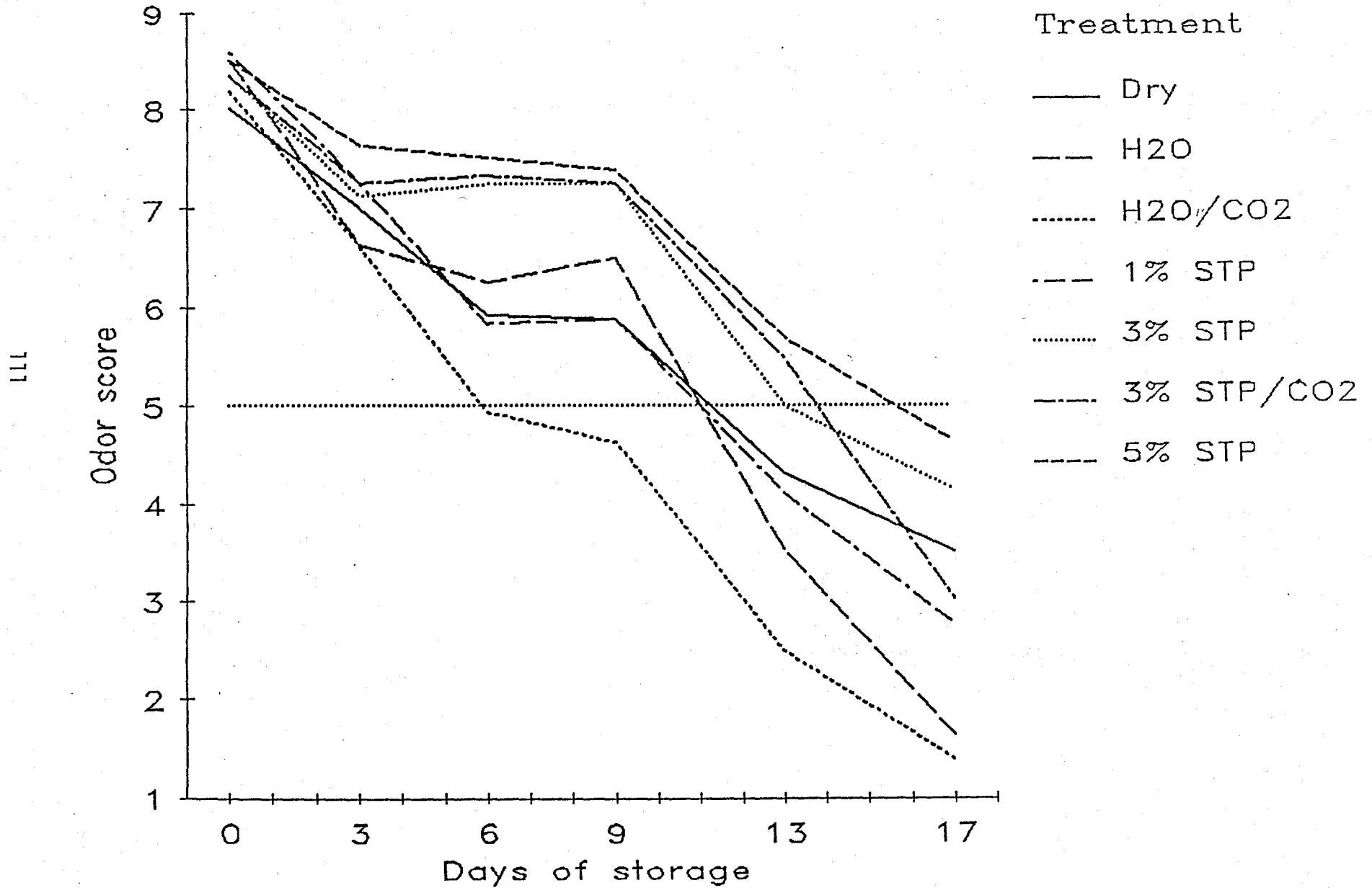

# Cooked flavor scores

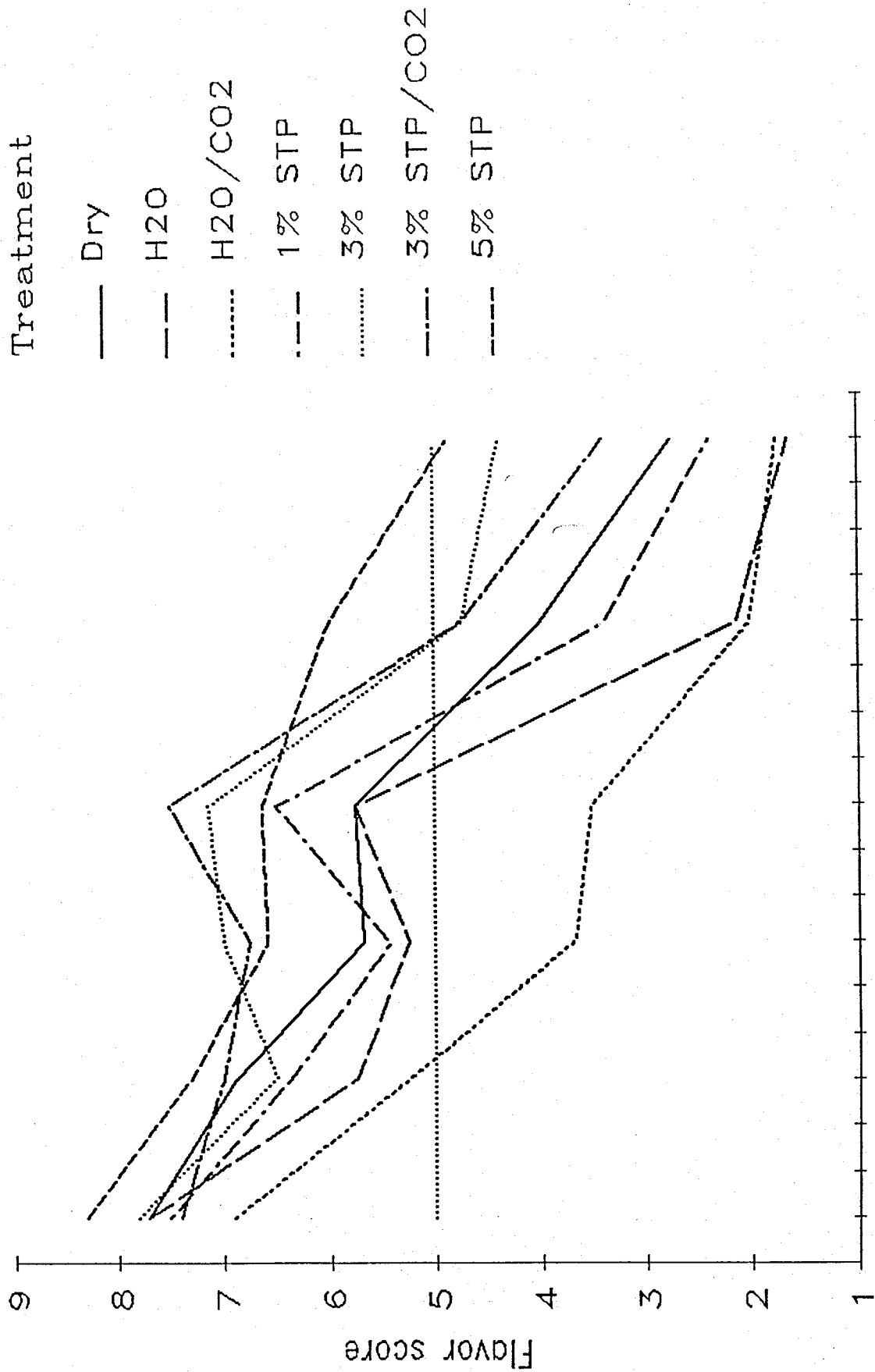

# Cooked texture scores

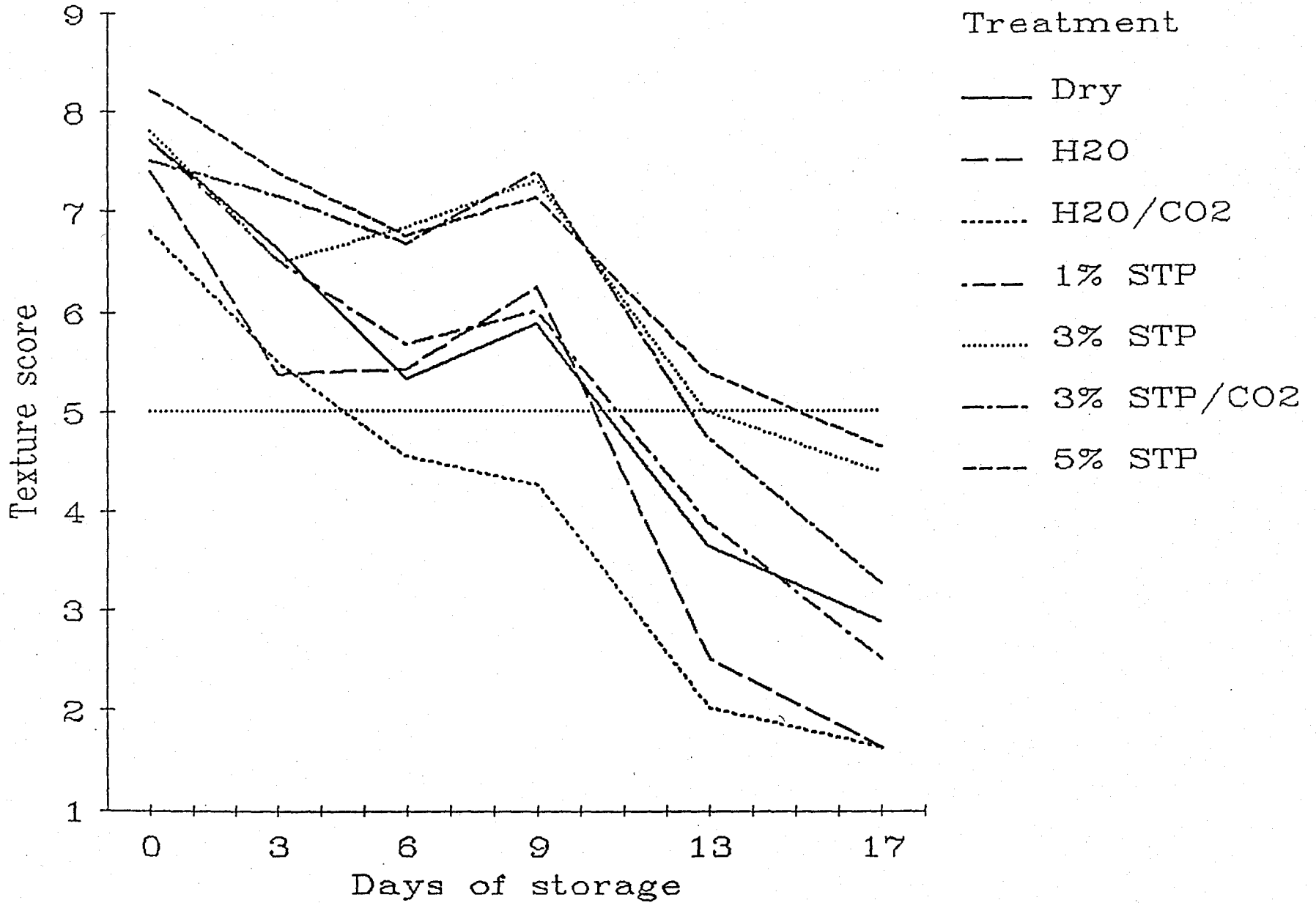

Raw appearance scores (2 hr. soaks)

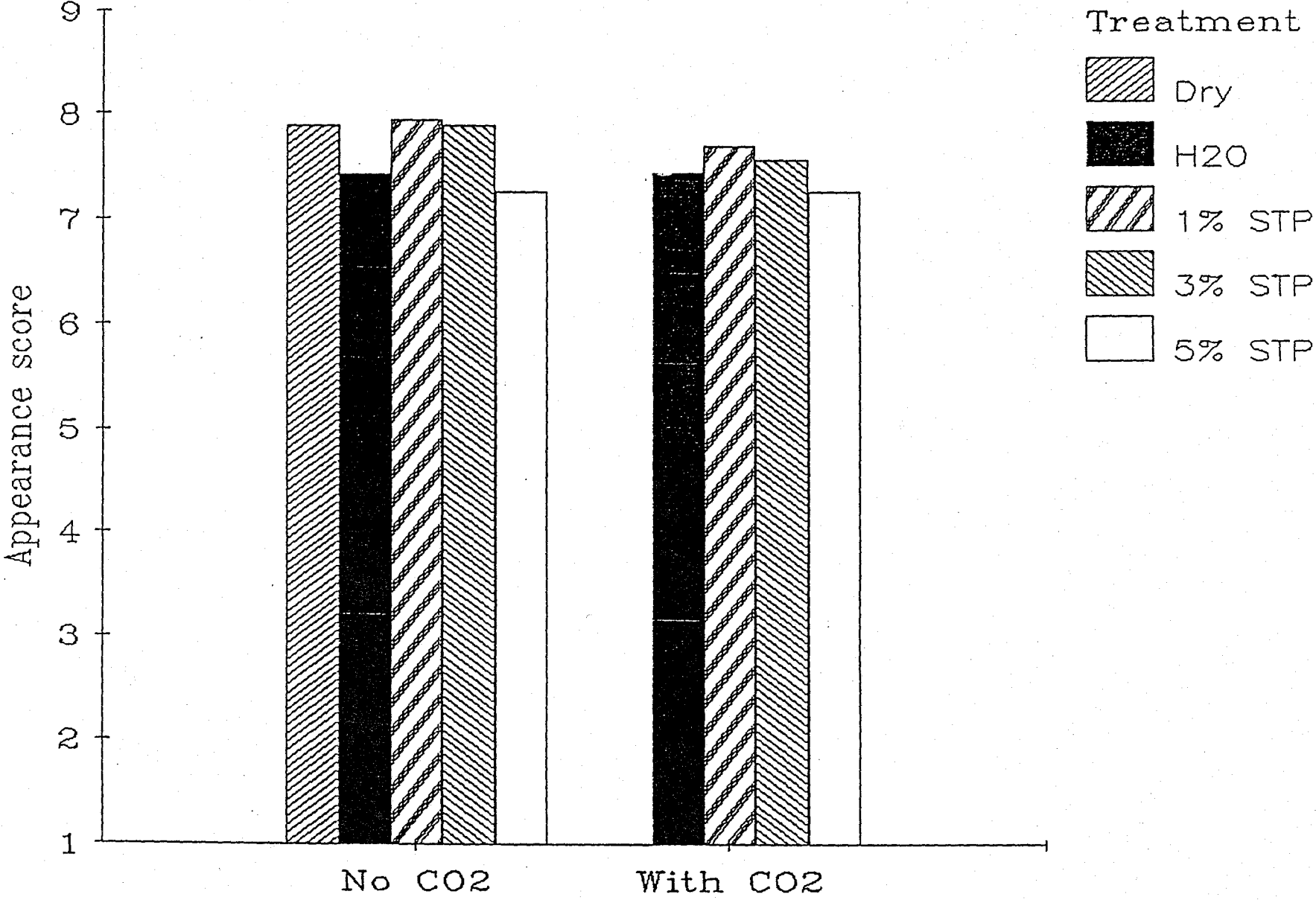



Raw odor scores (2 hr. soaks)

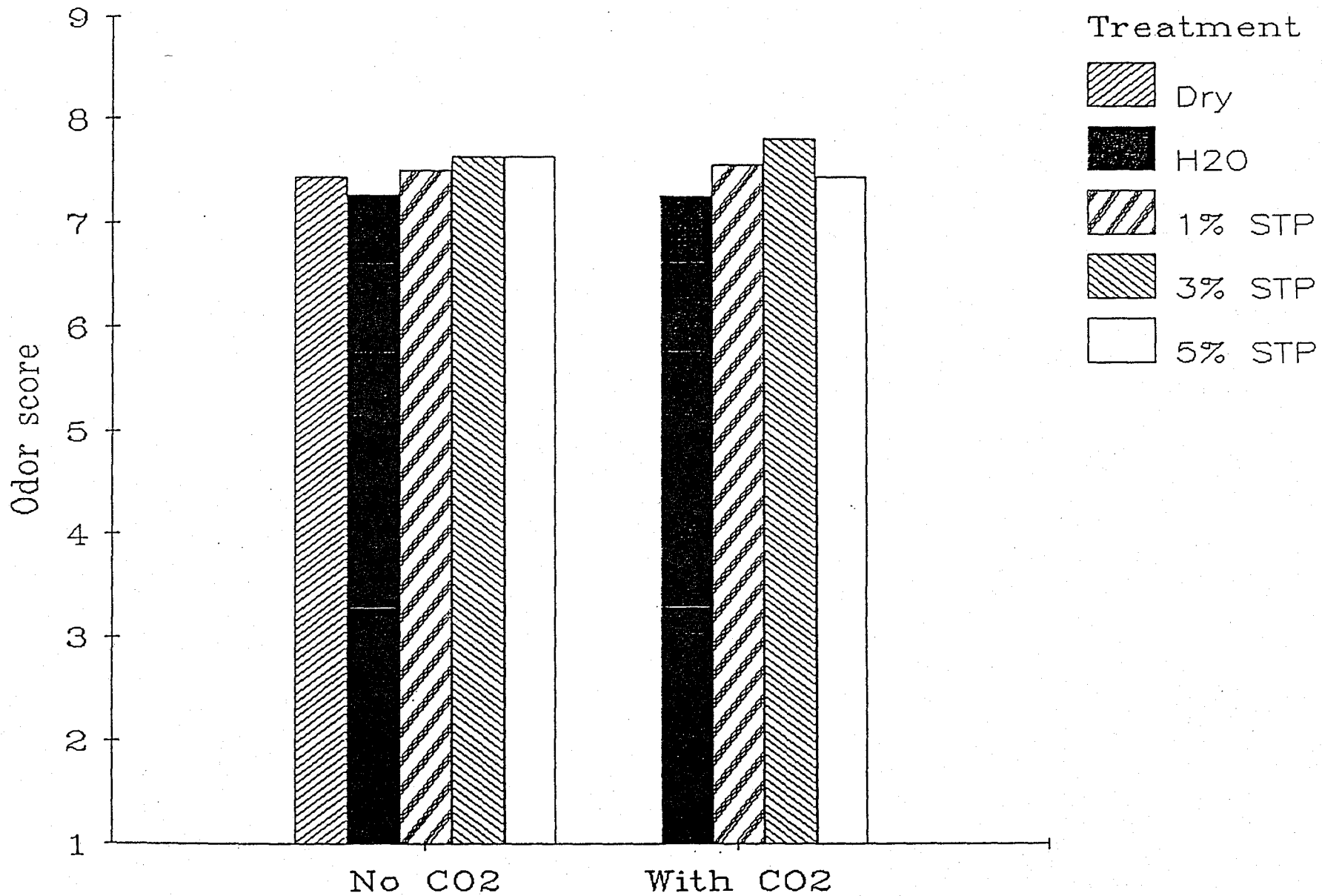

## Cooked Appearance scores (2 hr. soaks)

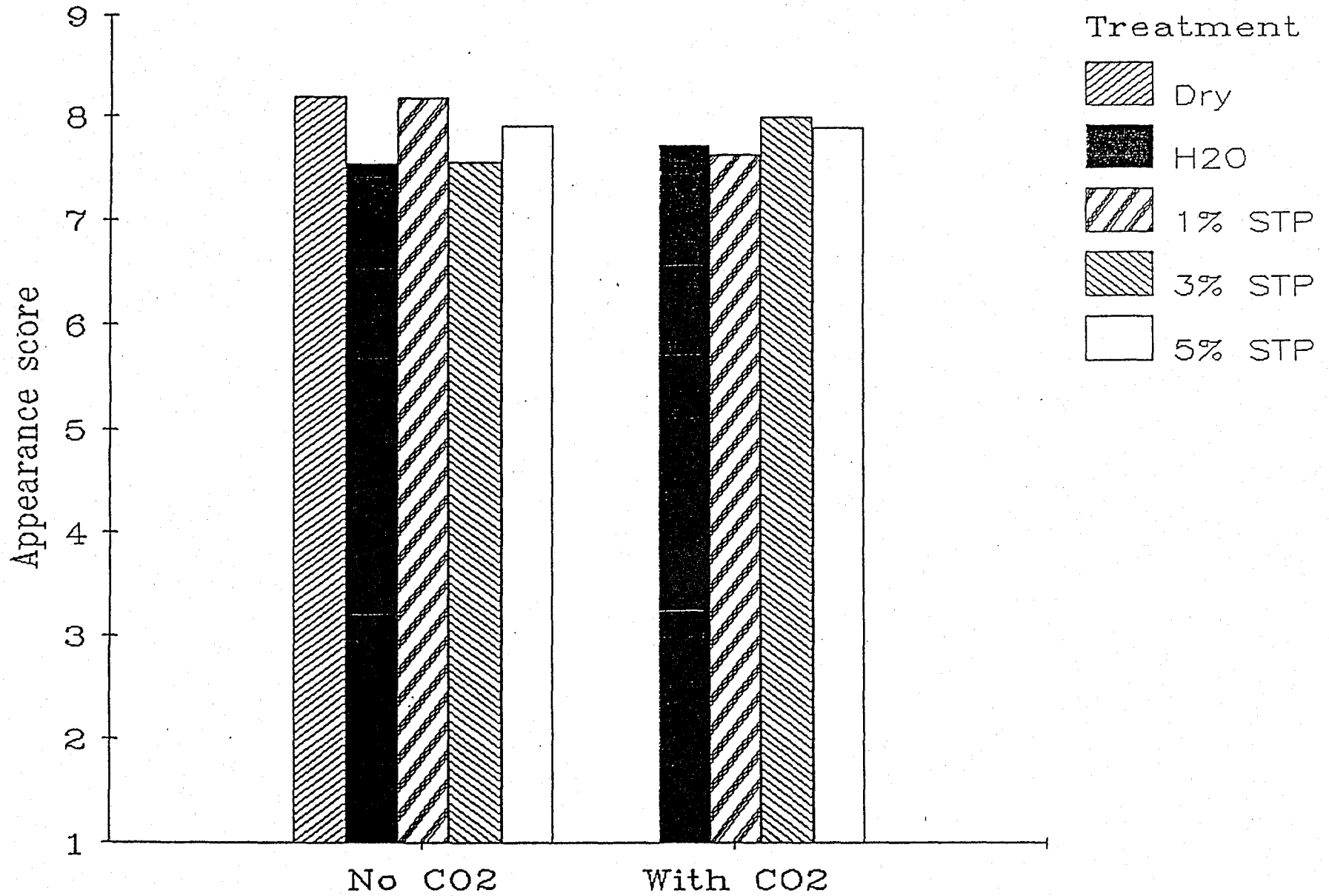

# Cooked odor scores (2 hr. soaks)

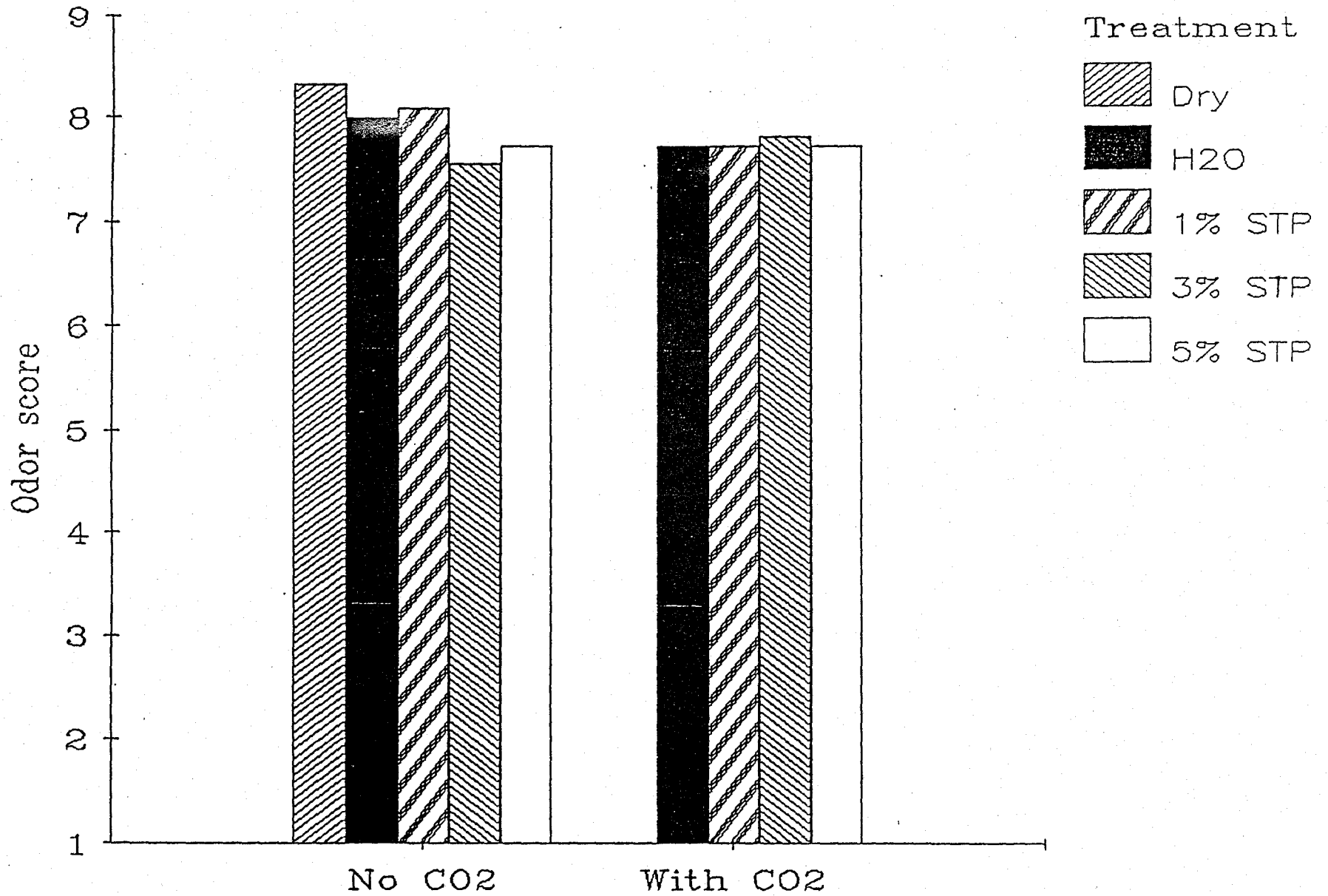

## Cooked flavor scores (2 hr. soaks)

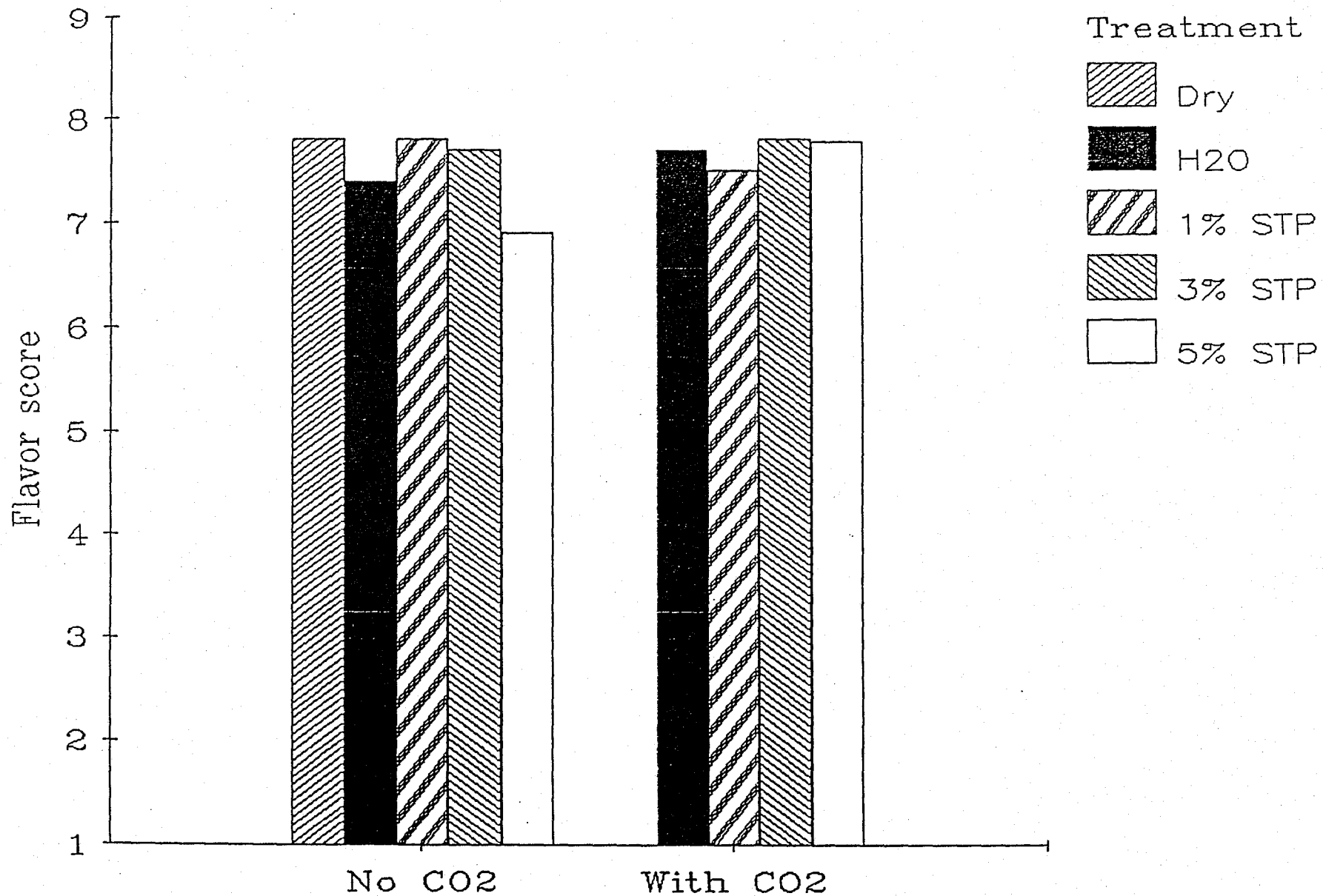

# Cooked shear resistance, peak ht. (2 hr. soaks)

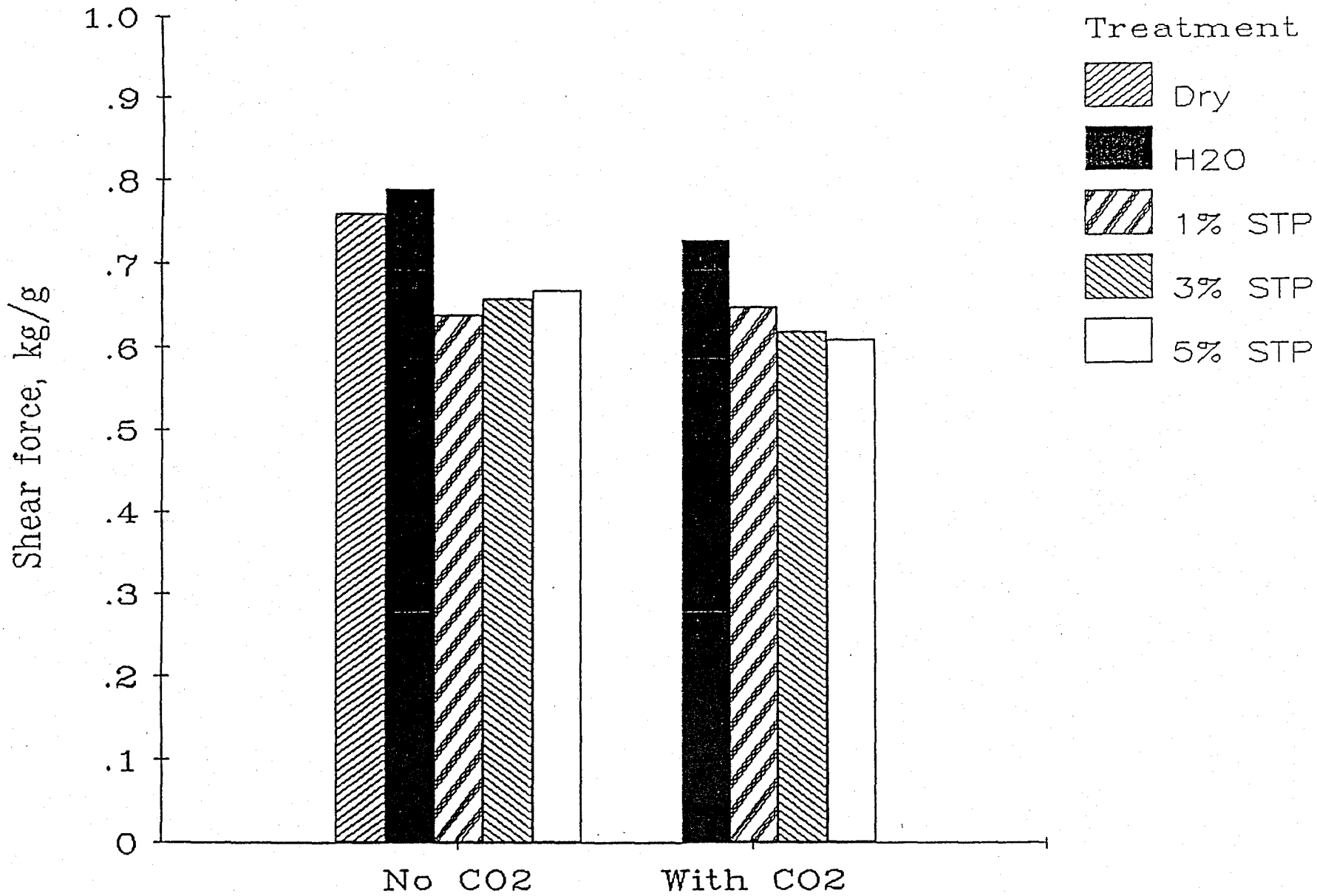

# Raw expressible moisture (2 hr. soaks)

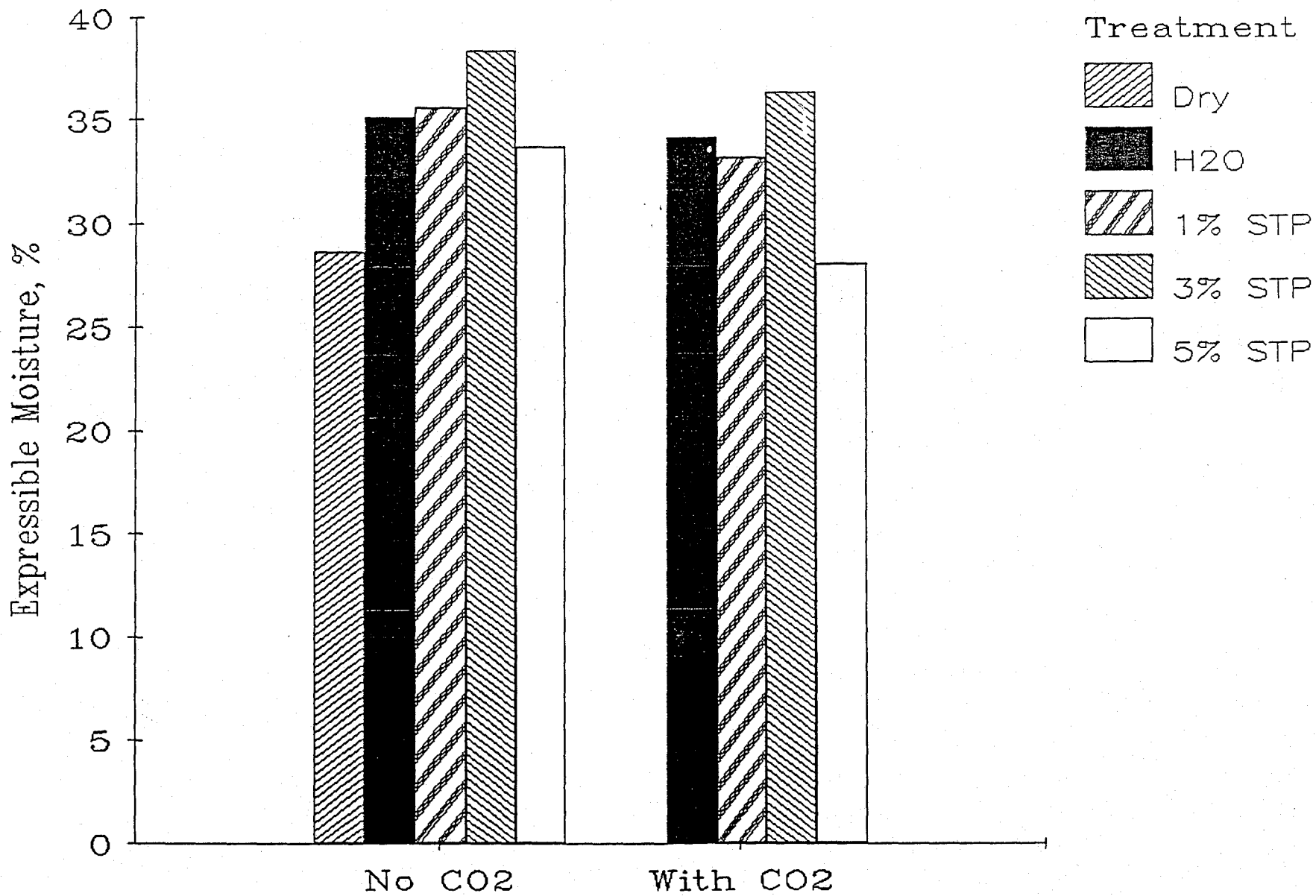

# Weight gain and thaw drip (2 hr. soaks)

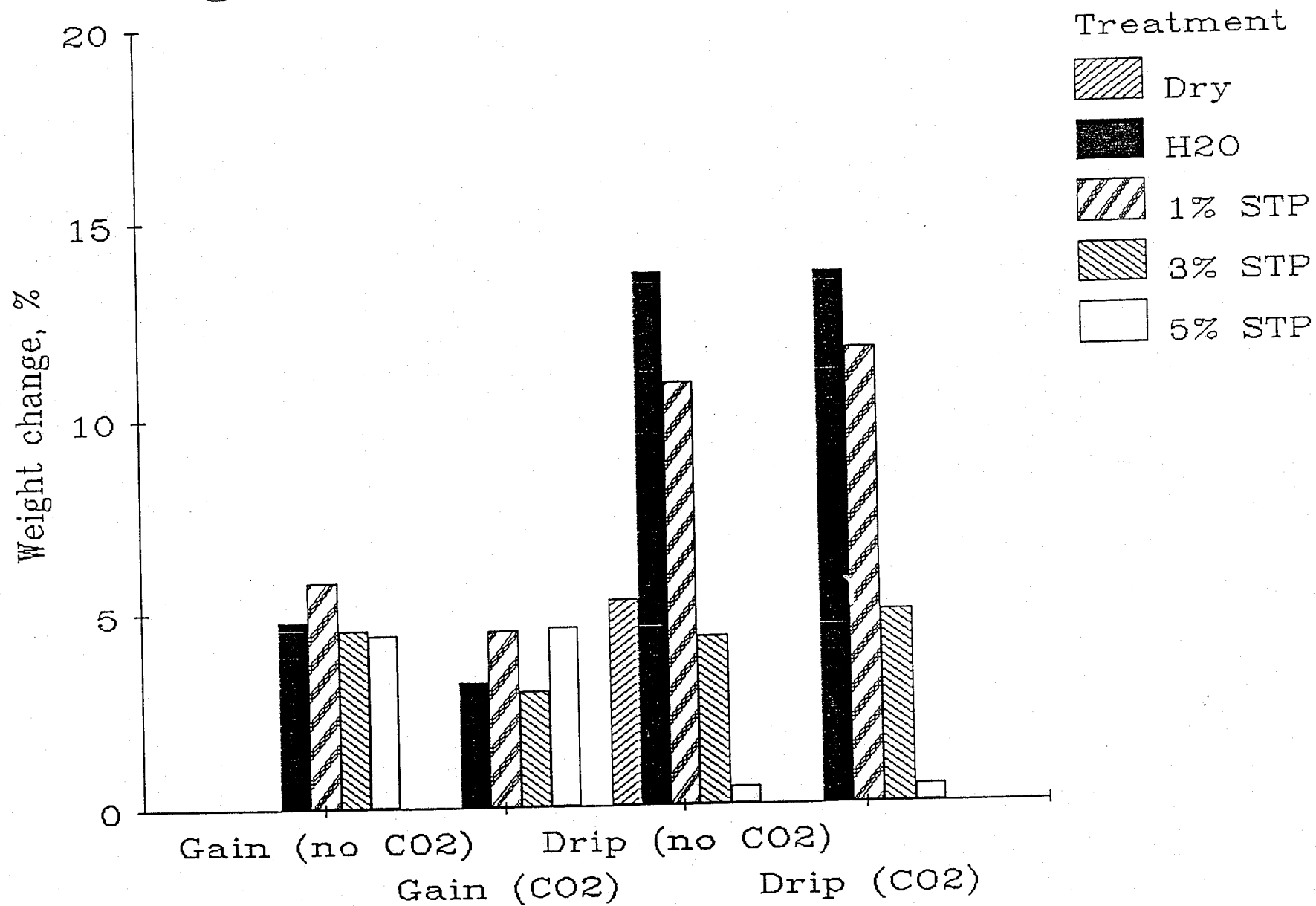

# Cook losses, % (2 hr. soaks)

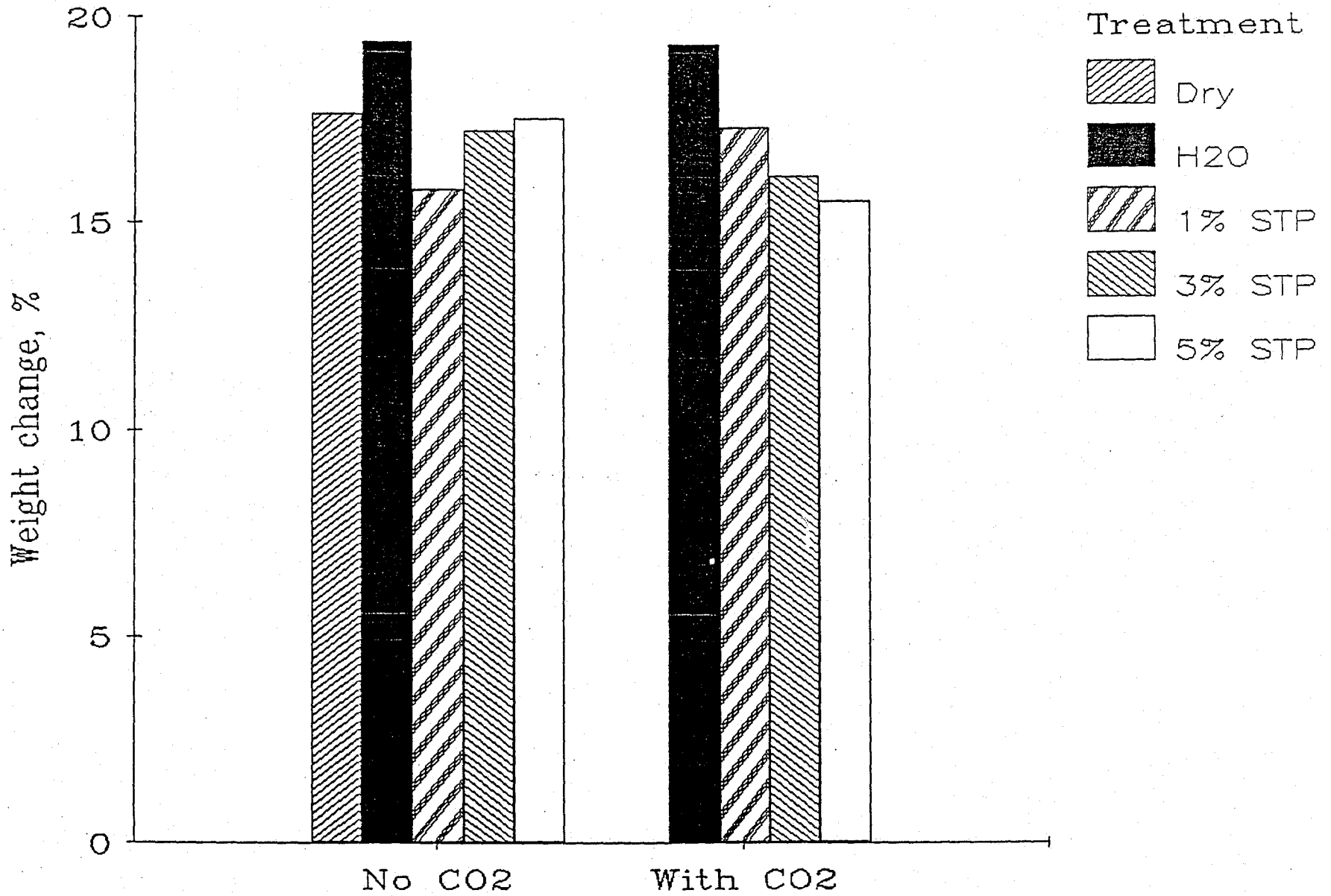



# Net yields, thawed and cooked (2 hr. soaks)

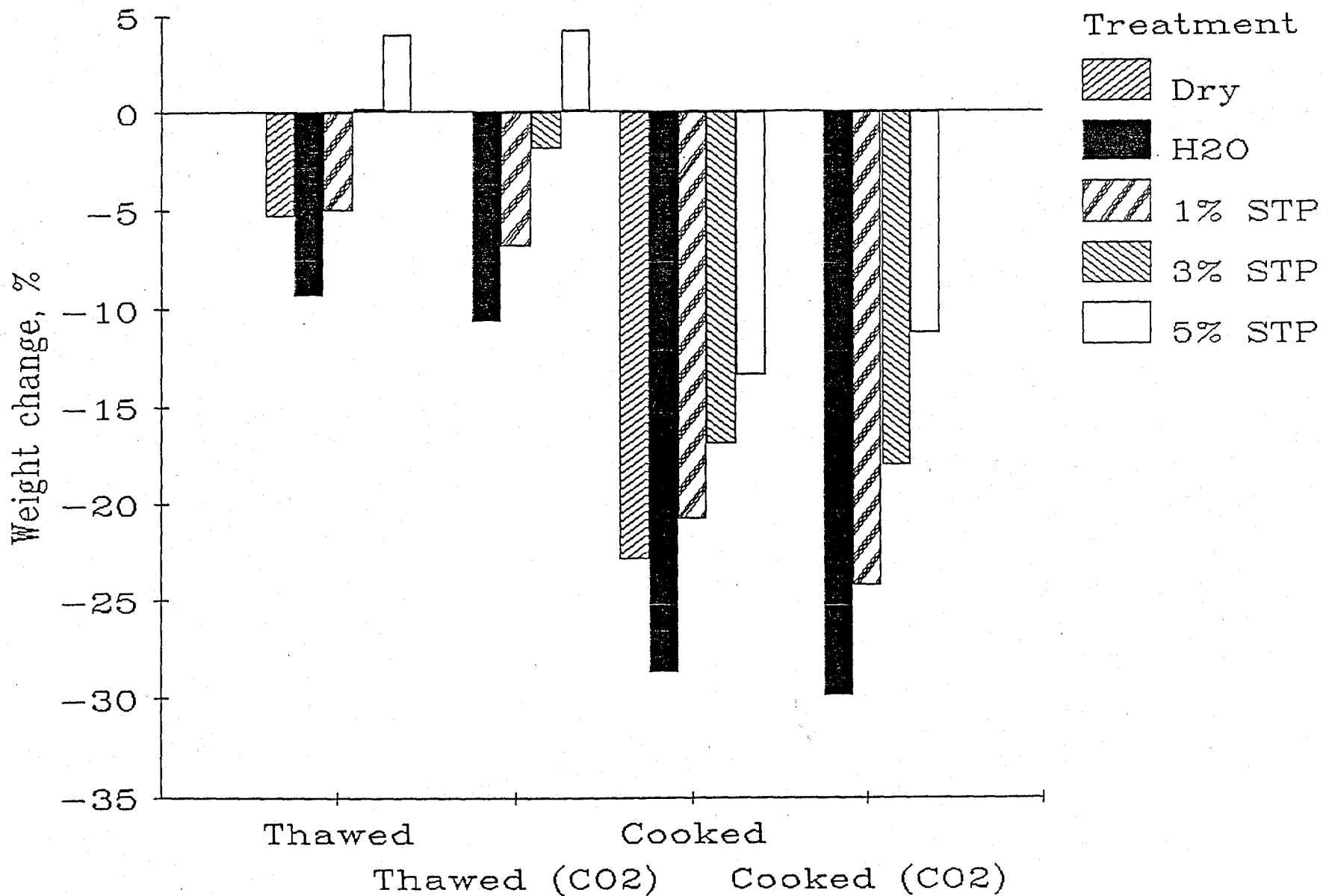

# Appendix 7

NAME:

DATE: September 14, 1992 TRAINING SESSION

## RAW SCALLOP EVALUATION

**INSTRUCTIONS:** Please evaluate the scallop samples with a vertical mark on the horizontal scale based on the characteristic indicated in each block

SAMPLE #:

	EVALUATION CHARACTERISTIC:	APPEARANCE
	Fresh	Not Fresh
	EVALUATION CHARACTERISTIC:	ODOR
	Fresh	Not Fresh

NAME:

DATE: September 14, 1992 TRAINING SESSION

COOKED SCALLOP EVALUATION

INSTRUCTIONS: Please evaluate the scallop samples with a vertical mark on the horizontal scale based on the characteristic indicated in each block

SAMPLE #:

EVALUATION CHARACTERISTIC:		APPEARANCE
Fresh		Not Fresh

EVALUATION CHARACTERISTIC:		ODOR
Fresh		Not Fresh

EVALUATION CHARACTERISTIC:		FLAVOR
Fresh		Not Fresh

EVALUATION CHARACTERISTIC:		TEXTURE
Fresh		Not Fresh

MARKET INSIGHT

STP. WASH

Name: \_\_\_\_\_

SCALLOP TASTE TEST 11/17/92 GROUP 1 2 3 4 5 6

Please look at the scallops but **DO NOT TASTE** them yet.  
Answer the following questions about their **appearance**:

1. Overall, how much do you LIKE the APPEARANCE of these scallops?
- |           |            |          |                  |          |            |           |
|-----------|------------|----------|------------------|----------|------------|-----------|
| 1         | 2          | 3        | 4                | 5        | 6          | 7         |
| dislike   | dislike    | dislike  | neither          | like     | like       | like      |
| very much | moderately | slightly | like nor dislike | slightly | moderately | very much |

Please smell the scallops but **DO NOT TASTE** them yet.  
Answer the following question about their **aroma**:

2. Overall, how much do you LIKE the AROMA of these scallops?
- |           |            |          |                  |          |            |           |
|-----------|------------|----------|------------------|----------|------------|-----------|
| 1         | 2          | 3        | 4                | 5        | 6          | 7         |
| dislike   | dislike    | dislike  | neither          | like     | like       | like      |
| very much | moderately | slightly | like nor dislike | slightly | moderately | very much |

Please take a bite of cracker and two sips of water. Now eat at least two scallops and answer the following questions about their **TASTE/FLAVOR** and **TEXTURE**:

3. Overall, how much do you LIKE the FLAVOR of these scallops?
- |           |            |          |                  |          |            |           |
|-----------|------------|----------|------------------|----------|------------|-----------|
| 1         | 2          | 3        | 4                | 5        | 6          | 7         |
| dislike   | dislike    | dislike  | neither          | like     | like       | like      |
| very much | moderately | slightly | like nor dislike | slightly | moderately | very much |

4. How STRONG is the FLAVOR of these scallops?
- |           |   |   |   |   |   |             |
|-----------|---|---|---|---|---|-------------|
| 1         | 2 | 3 | 4 | 5 | 6 | 7           |
| very weak |   |   |   |   |   | very strong |

5. How SALTY are these scallops?
- |                  |   |   |   |   |   |            |
|------------------|---|---|---|---|---|------------|
| 1                | 2 | 3 | 4 | 5 | 6 | 7          |
| not salty at all |   |   |   |   |   | very salty |

6. What do you think of this SALTY taste?
- |                  |   |   |            |   |   |           |
|------------------|---|---|------------|---|---|-----------|
| 1                | 2 | 3 | 4          | 5 | 6 | 7         |
| not salty enough |   |   | just right |   |   | too salty |

7. After swallowing, how STRONG is the AFTERTASTE of these scallops?
- |           |   |   |   |   |   |             |
|-----------|---|---|---|---|---|-------------|
| 1         | 2 | 3 | 4 | 5 | 6 | 7           |
| very weak |   |   |   |   |   | very strong |

8. Overall, how much do you LIKE the TEXTURE of these scallops?
- |           |            |          |                  |          |            |           |
|-----------|------------|----------|------------------|----------|------------|-----------|
| 1         | 2          | 3        | 4                | 5        | 6          | 7         |
| dislike   | dislike    | dislike  | neither          | like     | like       | like      |
| very much | moderately | slightly | like nor dislike | slightly | moderately | very much |

9. How FIRM are these are these scallops?
- |           |   |   |   |   |   |           |
|-----------|---|---|---|---|---|-----------|
| 1         | 2 | 3 | 4 | 5 | 6 | 7         |
| very soft |   |   |   |   |   | very firm |

10. What do you think of this FIRMNESS?

1                      2                      3                      4                      5                      6                      7  
too soft                      just right                      too firm

11. How MOIST are these scallops?

1                      2                      3                      4                      5                      6                      7  
very dry                      very moist

12. What do you think of this MOISTNESS?

1                      2                      3                      4                      5                      6                      7  
too dry                      just right                      too moist

After you have finished sampling the scallops,  
please answer the following questions:

13. Overall, how much do you like these scallops?

1                      2                      3                      4                      5                      6                      7  
dislike                      dislike                      dislike                      neither                      like                      like                      like  
very much                      moderately                      slightly                      like nor                      slightly                      moderately                      very much  
dislike

14. Overall, how would you rate the QUALITY of these scallops?

1                      2                      3                      4                      5                      6                      7  
very low quality                      very high quality

15. Overall, how does this product COMPARE to the scallops you USUALLY eat?

1                      2                      3                      4                      5                      6                      7  
much worse                      about the same                      much better

16. The average RETAIL price for fresh raw scallops is \$6.99 per pound. If you had purchased these scallops uncooked, at that price, how would you feel about their VALUE after you'd prepared them?

1                      2                      3                      4                      5                      6                      7  
paid too much                      paid fair price                      got a bargain

17. If you were served these scallops prepared as you requested, at a RESTAURANT, what would be your opinion of them based on your EXPECTATION?

1                      2                      3                      4                      5                      6                      7  
worse                      about as                      better  
than expected                      expected                      than expected