

VALUABLE POSSESSIONS:
WEALTH, PRESTIGE, AND SOCIAL MOBILITY
IN THE COLONIAL CHESAPEAKE.

A Thesis

Presented to

The Faculty of the Department of History
The College of William and Mary in Virginia

In Partial Fulfillment

Of the Requirements for the Degree of
Master of Arts

by

Whitney L. Battle

2001

APPROVAL SHEET

This thesis is submitted in partial fulfillment of
the requirements for the degree of

Master of Arts

Whitney L. Battle

Approved, May 2001

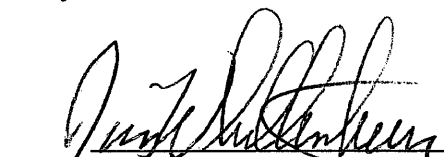
James Whittenburg

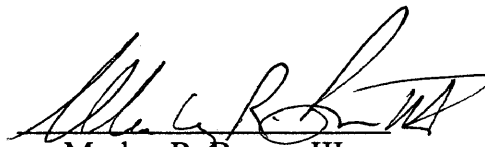
Marley R. Brown III

Julie Richter

TABLE OF CONTENTS

	Page
ACKNOWLEDGEMENTS	iv
LIST OF FIGURES	v
ABSTRACT	vi
INTRODUCTION	2
CHAPTER I: THE EARLY CHESAPEAKE: LABOR, TOBACCO, AND SLAVERY	4
CHAPTER II: WILLS, INVENTORIES, AND HISTORICAL INTERPRETATION	11
CHAPTER III: THE CRAWLEYS	21
CHAPTER IV: THE TIMSONS	47
CHAPTER V: CONCLUSION	70
APPENDICES	74
BIBLIOGRAPHY	101

ACKNOWLEDGEMENTS

The writer wishes to express her appreciation to Dr. James Whittenburg, for his patience, guidance, and criticism through the research and writing of this thesis. The author would also like to thank Dr. Marley Brown, Dr. Julie Richter, and Dr. Maria Franklin for their careful reading and criticism of the manuscript.

The writer must also express her appreciation to all those who patiently read and reread draft after draft of this work, especially Andrea Battle, Stephen Brighton, C. Whitaker Battle, and Dr. Larry McKee. I would also like to thank Jennifer Jones for all of her assistance with the final drafts of the manuscript.

Finally, the writer would like to dedicate this thesis to H. Lawrencie Jones and Edith Lutricia Johnson for their constant support and inspiration through the years. The both of you will be greatly missed.

LIST OF FIGURES

Figure		Page
	Crawley Genealogy:	
1	Robert Crawley	21
2	Robert Crawley III	22
3	John Crawley	23
	Timson Genealogy:	
4	Samuel Timson	47
5	William Timson	48
6	Samuel Timson III	49

ABSTRACT

The Chesapeake region of Maryland and Virginia became the new home of an entire generation by the mid-seventeenth century. The possibilities and opportunities of life in the coastal colonies led a steady stream of young English immigrants to the shores of North America. The initial success of Chesapeake tobacco allowed those who emigrated to Virginia economic freedom unheard of in England.

The stories of two particular individuals who lived in Virginia during the seventeenth century provide an interesting glimpse into details of life at a crucial time in the colony's history. Robert Crawley arrived as an indentured servant. Samuel Timson came as a free man with wealth and colonial connections. Yet, both men used similar strategies in the pursuit of economic, political, and social success in the New World.

The last quarter of the seventeenth century was also a time when the Chesapeake region began to shift its labor force from white indentured servants to enslaved Africans. As this transition occurred, the system of slavery altered social, economic, and political structures in the Chesapeake region. Tobacco's continuous demand for labor created an economic system that would become dependent on the system of slavery. Crawley and Timson experienced this shift and depended on the ownership of human property to ensure their economic success.

Through the use of public documents such as probate records, wills, and court records, this study traces the lifestyles of residents of the Chesapeake, demonstrates how land and property were acquired, and highlights the importance of the ownership of enslaved African labor. The success of both Timson and Crawley were directly linked to how they used land, how they distributed material wealth, and how human chattel were used as symbols of their position within colonial society.

The personal feelings and accounts of daily activities of ordinary citizens often went unrecorded in public documents. Yet, carefully analyzed documents are invaluable sources of information that allow for general discussions of more than elite white men. They have also been used to interpret the role of poor white men, enslaved Africans, women, and children in the social and political structure of colonial Virginia. The work of social historians, material culturalists, and historical archaeologists provides the interpretive framework through which the narratives of two men and their descendants can be told.

**VALUABLE POSSESSIONS:
WEALTH, PRESTIGE, AND SOCIAL MOBILITY
IN THE COLONIAL CHESAPEAKE**

INTRODUCTION

British interests in North America began as a strategy of colonial expansion. England attempted to tap into the natural resources and wealth potential enjoyed by other European countries such as Spain, Portugal, and France. The middle coastal region of the North American continent was the place where England successfully secured a foothold. The early failure of the Roanoke colony followed by the harsh conditions at Jamestown were not enough to discourage the colony's settlers, but a new strategy was needed to ensure survival. Jamestown had proven that settlers needed to be equipped with not only the desire for success, but also with the skills and drive to have endured all the realities of pioneer life.

Soon after Jamestown was settled, a successful agricultural potential emerged. Tobacco became the resource that made the Chesapeake region the largest and wealthiest colonial territory held by the British crown. However, to efficiently cultivate tobacco, an abundant amount of labor was needed. Conditions in England such as civil war, large population increases, limited land prospects, and high unemployment translated into an emigration boost to the Chesapeake Bay colonies. An entire generation of young, able-bodied men looked across the ocean and took a chance to possibly become men of wealth and prestige.

Robert Crawley was one of these men. In his early thirties he took the long journey to Virginia as an indentured servant. He survived his period of service, married, had children, bought land, and acquired a labor force that had allowed him to live as a man with material possessions, property, and a legacy for his descendants. Samuel

Timson embarked on his venture much later. He paid his own way and settled quickly into the role of the rising colonial elite. He also acquired land, material possessions, and the means to establish his family as one of the most socially and economically powerful in the Williamsburg area.

Although the stories of these two men differed in a number of ways, both actively participated in the developing economic system that had become dependent on tobacco. No longer were class and economic standing dictated by English standards; the colonial Chesapeake offered social opportunities to free men who made key strategic decisions.

As conditions in the colonies improved, planters looked to another source of Old World labor: the Atlantic slave trade. The number of English indentured servants who had become freemen with farms of their own increased. As the great influx of new English servants declined, and with the success of slavery in Caribbean colonies, the Chesapeake region was propelled toward enslaved African labor as a plausible alternative. Race-based slavery became the next economic strategy in Britain's quest for a secure hold on colonial trade.

Crawley and Timson prospered due to an increased dependency on enslaved labor. A lifetime of service and the ability of an enslaved community to naturally increase over time was at the center of a permanent economic and social shift of the common, white Chesapeake planter. The stories of Crawley and Timson indicate that the enslavement of a large number of Africans became the source of economic freedom for a minority of whites.

CHAPTER I
THE EARLY CHESAPEAKE :
LABOR, TOBACCO, AND SLAVERY

This study considers how ordinary immigrants created a distinct colonial economic and social system rooted in tobacco monoculture and African slavery. Social historians of colonial Virginia and Maryland have examined key moments in the late seventeenth and early eighteenth centuries that exemplified how the Chesapeake region became one of the most successful British settlements in the Americas. Historians of this time period focused on factors such as tobacco cultivation, settlement patterns, family development, and the establishment of a stable creole population. This study is influenced by that body of earlier scholarship, but seeks to focus specifically on the lives of two individuals.

Two English immigrants, Robert Crawley and Samuel Timson, are the focus of this research. Robert Crawley came to Virginia as an indentured servant, while Samuel Timson arrived in the colony with wealth and political advantages. However, whether in the quest for new or increased prosperity, both men used very similar strategies for success. Colonial profit and economic opportunity were among the top motivators for emigration to the New World. The risks associated with survival in the colonial Chesapeake often outweighed the prospects of financial success among the colony's first settlers. Overpopulation, high unemployment, and dwindling opportunities for economic prosperity in England sparked an entire generation to look across the Atlantic Ocean for

new possibilities.¹ Although the immediate comforts of the Chesapeake region were few and far between, the true lure of its shores lay in the potential control over one's life. Lois Green Carr stated that, "...this control [had come] through the achievement of economic independence and some access to political participation" that would have been unheard of in England.²

Virginia was the first and largest British settlement of the New World. The initial objective of the colony was a conquest of sorts. For England to have protected its foothold in the Americas, the continent had to provide some form of profit for the crown.³ Initially, the population that settled the colony did not consist of farmers or men bent on staying for long periods of time. Investors and colonists alike concentrated on the establishment of a solid commercial trade and only focused on methods that ensured immediate profit. The initial settlers were unable to fend for themselves because they were unaccustomed to subsistence farming. In addition, they were ill-equipped to adjust to the new and strange environment of the region. The various efforts to discover a successful venture that would yield a profit failed at every turn.⁴ It was not until John Rolfe introduced a sweeter tasting of tobacco leaf from the West Indies that a profitable enterprise emerged. With tobacco's success, settlers found new motivations to establish a permanent, agriculturally-based society.

¹James Horn, Adapting to a New World: English Society in the Seventeenth-Century Chesapeake (Chapel Hill, 1994). See also James Horn, "Servant Emigration to the Chesapeake in the Seventeenth Century," in Thad Tate and David Ammerman, eds., The Chesapeake in the Seventeenth Century: Essays on Anglo American Society (New York, 1979) 51-95.

²Lois Green Carr, "Emigration and the Standards of Living: The Seventeenth-Century Chesapeake." Journal of Economic History, 52 (1992): 271-292.

³Jack P. Greene, Pursuits of Happiness: The Social Development of Early Modern British Colonies and the Formation of American Culture (Chapel Hill, 1988) 8-9.

⁴Edmund Morgan, American Slavery, American Freedom: The Ordeal of Colonial Virginia (New York, 1975) 83-91. Morgan describes the failure of many of the colony's efforts to establish a profitable venture

Jack P. Green's Pursuits of Happiness: The Social Development of Early Modern British Colonies and the Formation of American Culture gives an excellent overview of the transformation of Chesapeake society through the success of tobacco. Virginia began as a colony filled with self-interested individuals in pursuit of prosperity through tobacco and the labor needed to produce the crop shaped Chesapeake society as a whole.⁵ Greene also described the society that took shape in Virginia during these formative years. It was similar to what English immigrants would have known at home. As the hardships that they had to initially overcome began to dissipate, colonial Virginians sought the profits and benefits that successful colonization and tobacco cultivation promised.

When the seventeenth century came to an end, the insatiable need for labor by Virginia planters was met by a sharp decline in English immigration. Colonial planters then responded by making way for a complete transformation from indentured servants toward a system that used enslaved labor from Africa. Although the colony was still relatively young, the introduction of enslaved labor in the Chesapeake region occurred relatively late in comparison to their colonial neighbors in the Caribbean and South Carolina.

Planters in the Caribbean were wealthier and needed large numbers of enslaved Africans for sugar production, therefore slave traders sold a majority of their enslaved Africans to island planters in the seventeenth century. The tobacco economy in Virginia was initially unable to support a large enslaved population. Freemen who had survived their indentures moved from the highly populated areas to interior locations that had less

in Jamestown. See also Morgan's discussion of how tobacco became a profitable cash crop in Virginia, pp. 9-10 and pg. 90.

⁵ Ibid, pg. 10

agricultural competition.⁶ These freemen became the small and middling farmers that made up a majority of the Chesapeake population. Edmund Morgan pointed out that during this time immigrants continued to suffer high mortality rates. The uncertainty of life made the advantages of owning an enslaved laborer less appealing to the average planter. The short-term, less expensive English servant continued as the primary choice for these farmers.⁷ Their inability to maintain large land holdings and large labor forces made it almost impossible to immediately embrace the slave trade until much later.

After 1660, slavery became a plausible solution to the decline in English immigrants, but only for those who had sufficient capital. Only large planters who needed large numbers of laborers were able to bear the initial expense of purchasing enslaved Africans.⁸ This meant that the shift from indentured servitude to a system of slavery was a gradual one. Interracial work groups had begun to replace the all-white labor forces, and early on there was very little basis for differential treatment based on race.⁹ By 1675, enslaved Africans had become more than a makeshift answer to the shortage of bound workers from England. Exclusively enslaved African work groups replaced the interracial work groups relatively quickly. The number of enslaved Africans increased and the impact of this labor shift began to surface directly in the lives of all early Virginians. As time passed, Lorena Walsh observed, that the “acquisition of slaves was no longer an uncalculated response to a temporary shortage of free labor; it was

⁶ Kevin Kelly, “In dispers'd Country Plantations': Settlement Patterns in Seventeenth-Century Surry County, Virginia,” in Thad Tate and David Ammerman, eds., The Chesapeake in the Seventeenth Century: Essays on Anglo American Society (New York, 1979) 183-205.

⁷ Morgan, American Slavery, American Freedom, pg. 297.

⁸ Greene, Pursuits of Happiness, pg. 82.

⁹ Lorena Walsh, From Calabar to Carter's Grove: The History of a Virginia Slave Community (Charlottesville, 1997) 34. Walsh outlines the close relations shared by both white society and the enslaved African population. Colonial Virginians shared workspace, sleeping quarters, and a certain level of “social intimacy” that began to change when enslaved Africans became the majority of bound laborers.

becoming the very foundation of wealth and status of the Chesapeake elite.”¹⁰ Large plantation owners invested in the more expensive African laborer and they realized that, over time, profits increased several times over due to this initial investment.

As the dependency on enslaved labor grew, there were adverse effects on Virginia’s free white population. The increase of African laborers meant that freemen were eventually no longer the backbone of the Virginia labor force. This shift also meant that simply having survived a period of indenture no longer guaranteed economic prosperity.¹¹ Poor men found it difficult to compete with large coastal landholders, the growing creole population, and African laborers.

Many small farmers still found themselves unable to support short-term indentured servants and did not have the capital to bear the high cost of enslaved African labor. The small to middling farmers who had taken longer to transform their labor force were never able to achieve the success of larger plantations. Lorena Walsh’s recent book, From Calabar to Carter’s Grove: The History of a Virginia Slave Community, chronicled the development and transformation of early Chesapeake society from short-term, indentured labor to hereditary slavery based on race. Her book also followed the history of an enslaved community first established in the latter part of the seventeenth century and its transformation into a distinct African American community. Using a detailed

¹⁰ Ibid, pg. 25. Walsh discusses how the transformation during the Lewis Burwell II’s lifetime witnessed the growing necessity of enslaved African labor over that of the white indentured servant. See also Allan Kulikoff, Tobacco and Slaves: The Development of Southern Cultures in the Chesapeake, 1680-1800 (Chapel Hill, 1986). Kulikoff uses statistical, demographic, and historical data to trace the emergence of southern culture, both black and white. And how these close relations, especially with black/ white ratios in Virginia, influenced the overall development of the plantation system. Kulikoff’s use of demographic and statistical data are essential when attempting to recognize the labor shift over time, however, Kulikoff trends to lose the people behind the numbers and hard facts.

¹¹ Lois Green Carr and Russell Menard, “Immigration and Opportunity: The Freedman in Early Colonial Maryland,” in Thad Tate and David Ammerman, eds., The Chesapeake in the Seventeenth Century: Essays in on Anglo American Society (New York, 1979) 236.

analysis of account books and probates, Walsh traced the origins of a wealthy planter family and interpreted how enslaved people ensured the prosperity of the colonial elite.

Walsh believed that:

So long as blacks remained a distinct minority in the region's population, pressures for accommodation to the predominant language and culture were especially strong. And for a brief period between the 1660s and the mid-1680s, circumstances in the quarters were such that slaves could adopt parts of the dominant culture without perceiving that acceptance as a sign of capitulation.¹²

During the colony's move to a slave-based society, social and political structures were also altered. Although cultural interactions between enslaved Africans and free whites would have been common, one group never culturally dominated the other. At the turn of the century, the African population was still too small to have been a threat. As long as the transformation to slavery maintained a gradual pace, cultural interactions between enslaved people and their masters were negotiated on both sides.

The initial reliance on African males as laborers led to unbalanced sex ratios within the enslaved community and facilitated the slow growth of the population. Chesapeake slaveholders, however, saw the benefits of balanced sex ratios in their enslaved African populations. Balanced ratios of enslaved men and women also created new spheres of cultural exchanges among black and white colonists. These exchanges included changes in foodways, religious practices, agricultural methods, and architectural techniques.¹³

The characteristics of the colony during the seventeenth century were never easily defined. Walsh cautioned scholars of this time period that the "study of Chesapeake

¹² Walsh, From Calabar to Carter's Grove, pg. 34.

communities must rely on different sources from those used by scholars of New England, due to the significance of the loosely organized rural neighborhood rather than the structured town. The character, as well as the arena, of collective economic and social action that emerged also differed.”¹⁴ The lives of ordinary people who occupied these rural neighborhoods are the potential vehicles through which we may understand aspects of social mobility and the role of property within the colonial system. The case studies of Crawley and Timson that follow allow for such an interpretation. The strategies and methods used by both men as recorded in public documents reflected how the seventeenth century was a time of great transformation for the Virginia colony. Further, their actions demonstrate the importance of enslaved labor to that transformation.

In 1910 Thomas Jefferson Wertenbaker described the shift from English indentured servitude to black hereditary slavery as crushing the small independent farmer “beneath the black tide” of African labor.¹⁵ Enslaved African labor had begun to creep into the very core of colonial Virginia society, Wertenbaker argued. It had also become the very foundation for social, political, and economic success. These had all become the benefits of owning humans. It was “beneath the black tide” that the wealth of the colony had been built.

¹³ John Blassingame, The Slave Community: Plantation Life in the Antebellum South (New York, 1972) 101.

¹⁴ Lorena S. Walsh, “Community Networks in the Early Chesapeake,” in Philip Morgan, Lois Greene Carr, and Jean Russo, eds., Colonial Chesapeake Society (Chapel Hill, 1988) 200.

¹⁵ Thad Tate, “The Seventeenth-Century Chesapeake and its Modern Historians,” in Thad Tate and David Ammerman, eds., The Chesapeake in the Seventeenth Century: Essays on Anglo American Society (New York, 1979) 10. Tate described the key works by Wertenbaker and his unique approach to a “full spectrum” of seventeenth-century Virginia. Wertenbaker saw the early part of the seventeenth century as a “a yeoman democracy of small landowners” that could never have survived under the promotion of enslaved African labor that created a distinct class of large planters. This had made it impossible for small farmers to have survived without enslaved labor.

CHAPTER II
WILLS, INVENTORIES, AND
HISTORICAL INTERPRETATION

Reconstructing the lives of colonists who lived in the late seventeenth and early eighteenth centuries presents a number of challenges, especially where “ordinary” individuals are concerned. Probate records are a valuable tool for reconstructing lives in that they show consumption patterns, the standard of living, and the cultural value of material goods. Social and economic historians and historical archaeologists have been able to use information provided by probates and inventories to explore how possessions translate into larger social milieus. Wills can add to the understanding of colonial society on a more individual or personal level. Within this context, the significance that individuals place on their material possessions provides even greater insight into the value system of that society.

The critical analysis of public records helps to create images of the culture at-large and illustrates the role that various individuals played within the community in which he or she lived. The personal accounts left by the lower and middling classes such as diaries and memoirs are extremely rare. Therefore, early historians focused on the letters, diaries, probates, and wills left by elite southern planters. The elite, with their social and political importance, have always been the central figures in the

history of the American past.¹ Later historians used Revisionist, Progressive, and Consensus frameworks to convey how indentured white servants, white women, and enslaved African men and women impacted colonial society.² Gary Nash reflected on how the study of colonial America had changed with the rise of the new social history. Nash viewed the “history of social relations between groups of people defined by race, gender, and class” as a substantial contribution.³ One proven method used by these social historians provided the framework for analysis of varied social groups and systems of social stratification through public documents.

Writing the biographies of Robert Crawley and Samuel Timson is possible primarily through the interpretation of public documents. A majority of what survived regarding these two men was in the form of probates, court records, and wills. According to Gloria Main, probate records come in three major forms: wills, inventories, and accounts of administration.⁴ Main further explained how each different document functioned, stating that: “[t]he first directed the disposition of property. The second itemized and evaluated the forms of that property. The third

¹ Ulrich B. Phillips, American Negro Slavery (Glouster, 1959 [c1918]) and Ulrich B. Phillips, Life and Labor in the Old South (Boston, 1963 [c.1929]) were thought of as the most influential study of slavery that appeared in the interwar years. See also Peter Novick, That Noble Dream: The "Objectivity Question" and the American Historical Profession (Cambridge, 1988). Novick discusses the complexity of Phillips argument for the times, commenting on how Phillips' work was “[f]elicitously written, based on monumental research, and filled with important insights into the complexities of the slave-master relationship.”

² Just after World War II the most striking dissent within the historical profession began. Younger historians were beginning to question Phillip's authority and his subjective analysis of North American slavery. Scholars such as Melville Herskovits, The Myth of the Negro Past (New York, 1941); Gunnar Myrdal, An American Dilemma: The Negro Problem and Modern Democracy (New York, 1944); Kenneth Stampp, The Peculiar Institution: Slavery in the Antebellum South (New York, 1956); and Stanley Elkins, Slavery: The Problem in American Institutional and Intellectual Life (Chicago, 1959) are examples of new directions and new questions being posed in the study of the 18th and 19th century southern history.

³ Gary B. Nash, “Social Development,” in Jack P. Greene and J. R. Pole, eds., Colonial British America: Essays in the New History of the Early Modern Era (Baltimore, 1984) 233.

furnished reports to the court on the disposition of property in intestacy cases” to legally settle an estate dispute.⁵ This study, based primarily on the public documents of Crawley and Timson, uses a method described by Lois Green Carr and Lorena S. Walsh as an analysis centered on the “relationships of wealth and the process of its acquisition to systems of social stratification.”⁶

Through public documents the narratives of two men emerge. These men had ventured to colonial Virginia in search of a new life for themselves, but there were also other people who were a part of their stories, including wives, mothers, children, and enslaved Africans. All of these participants were components of their lives, and the interactions that took place created a past that is traditionally absent from earlier studies of seventeenth-century colonial history.

“Domestic Props”: The Probate Record

Social historians discovered that probate records were invaluable sources in the analysis of colonial consumption patterns in the late seventeenth and early eighteenth centuries. Gloria Main described consumption goods as any “household and personal goods in the inventory not used for the earning of income.”⁷ These goods can indicate the standard of living, the cultural value of items in society, and can provide a sense of how household space was used.

⁴ Gloria Main, “Probate records as a source for early American history,” William & Mary Quarterly 32 (1972): 89-99.

⁵ Ibid, pg. 90.

⁶ Lois Green Carr and Lorena S. Walsh, “Inventories and the Analysis of Wealth Consumption Patterns in St. Mary's County, Maryland, 1656-1777,” Historical Methods 13.2 (1980): 81-104.

⁷ Gloria Main, “The Standards of Living in Colonial Massachusetts,” Journal of Economic History 43 (1983) .pg. 102.

When scholars of colonial America combed through wills, deeds, inventories, and probates it was difficult to interpret precisely what many of these documents revealed about specific people. By this time, the fields of economic history and material culture studies had emerged as essential allies in how early American scholars analyzed their data. These scholars used material items indicated on probates and inventories as windows into various aspects of how the owner may have lived. Jules Prown described the analysis of material culture as “[t]he underlying premise...that objects made or modified by man reflect, consciously or unconsciously, directly or indirectly, the beliefs of the individuals who made, commissioned, purchased, or used them and by extension, the beliefs of the larger society to which they belonged.”⁸ The methods used in material culture studies had enabled the scholar to understand those traditionally considered non-literate and inaccessible through written sources.⁹

The methods used by scholars of early American history created a wealth of information. A number of interpretive methods are used in the analysis of probate records. Historians and historical archaeologists who concentrated on the seventeenth and eighteenth centuries saw the significance of objects and how they were connected to colonial culture. Historians, on the one hand, use probate records as a valuable written source that demonstrate first hand specific changes in life styles over time, wealth patterns, and the distribution and consumption of wealth within a society.¹⁰

⁸ David Jules Prown, “Mind in Matter: An Introduction to Material Culture Theory and Method,” in Robert Blair St. George, ed., Material Life in America, 1600-1860 (Boston, 1988) 18. Prown describes the term material culture as a branch of social history and cultural anthropology. “The term material culture thus refers quite directly and efficiently, if not elegantly, both to the subject matter of the study, material, and to its purpose, the understanding of culture.”

⁹ Ibid, pg. 20.

¹⁰ Ibid, pg. 81.

Archaeologists, on the other hand, turn to probate records in order to determine the possible function of vessels, to corroborate archaeological findings, and to create a broader interpretation of the cultural period in question.¹¹ “Since the windows that these records open on the hidden lives of ordinary people make these documents of inestimable value to historians, care must be taken that those windows do not distort the view,” warned Main.¹² Historians examine probate inventories and trace how attitudes toward personal possessions held larger social implications. Another important component utilized by the historian is how the documents of the deceased had direct implications for the society of the living. In other words, as the level of consumption increased, the significance of objects reflected more than those inventoried, “it demonstrates that the standard of consumption was rising among the living as well as the dead. Regardless of how wealth was distributed in the society as a whole, all groups were enjoying the improvement.”¹³

The fragmentary nature of the probate record, however, was quite obvious to historians. Therefore, alternative sources were needed to provide a more comprehensive view unavailable simply through probates.¹⁴ Information recovered archaeologically, the interpretation of folk architecture, and economic analyses of

¹¹ Mary Beaudry, “Words for things: linguistic analysis of probate inventories,” in Mary Beaudry (ed.), Documentary Archaeology of the New World (Boston, 1988) 43.

¹² Gloria Main, “The Standards of Living in Colonial Massachusetts,” Journal of Economic History 43 (1983), pg. 102.

¹³ Lois Green Carr and Lorena S. Walsh, “Inventories and the Analysis of Wealth Consumption Patterns in St. Mary's County, Maryland, 1656-1777,” Historical Methods 13.2 (1980), pg.90-91.

¹⁴ D. S. Smith, “Underegistration and bias in probate records: and analysis of data from eighteenth-century Hingham, Massachusetts,” William & Mary Quarterly 3s.32 (1975): 100-112. See also Gloria Main, “Probate records as a source for early American history,” William & Mary Quarterly 32 (1972): 89-99. Main describes the need to use alternate sources such as tax lists, farm accounts, war lists, and if they exist account books.

British colonialism together have led to a comprehensive interpretation of life in the colonial Chesapeake.

Archaeologist Paul Shackel asserted that “[o]nly a few scholars have analyzed the material goods found in probate inventories from an anthropological perspective that takes into account the symbolic and active meanings of material culture.”¹⁵ Moreover, the probate inventory has another valuable use within archaeological interpretation. It is what archaeologist Marley Brown described as the “basis for reconstructing the spatial contexts and functional dimensions of colonial American material culture.”¹⁶ The social implications for the ways in which particular goods were used, displayed, and given meaning has elevated the probate record as an important piece of evidence for the archaeologist. Shackel described this interpretative method as a process that creates an active voice for inanimate objects that he terms the “nonverbal meaning” of goods.¹⁷

Archaeologists have used probates to chart changes through time, specifically in the way in which material goods reflect changes in social attitudes toward individual consumption.¹⁸ For example, an increased presence of sets of dishes, knives and forks, and serving vessels in colonial inventories directly related to the

¹⁵ Paul Shackel, “Probate Inventories and Material Culture: An Archaeology of Annapolis, Maryland, 1695-1870,” in Barbara J. Little, ed., Text Aided Archaeology (Boca Raton, 1992) 205.

¹⁶ Marley R. Brown III, “The Behavioral Context of Probate Inventories: An Example from Plymouth Colony,” in Mary Beaudry, ed., Documentary Archaeology in the New World (Boston, 1988).

¹⁷ Shackel, “Probate Inventories and Material Culture,” Text Aided Archaeology, pp. 205.

¹⁸ *Ibid*, pg. 205. Shackel uses probate inventories in conjunction with etiquette books to trace the changing attitudes people had toward dining and health and hygiene- related behavior in Annapolis, Maryland. See also Mary Beaudry, “Words for things: linguistic analysis of probate inventories,” in Mary Beaudry, ed., Documentary Archaeology of the New World (Boston, 1988). Beaudry examines language and the use of modifiers to distinguish material goods from one another. These differentiations reflect trends toward more individualized use of ceramics and other vessels.

emergence of segmented dining among colonial families.¹⁹ Many archaeologists have pointed out how the market for such items increased as the eighteenth century progressed. Also, greater access to ceramics and nonessentials allowed middling and small farmers to participate in the dining practices of gentle folk. Many of these trends were visible in the actions of the later descendants of both Robert Crawley and Samuel Timson. As their descendants began to inherit essential items, monies were allocated for elaborate material goods not present in most households during the late seventeenth century.

Recently, a combined effort among social and economic historians, architectural historians, and historical archaeologists led to an interdisciplinary interpretation of the various meanings material culture meant for the society that used these objects. Prime examples of this approach have appeared in such works as: Of Consuming Interests (1994), Colonial Chesapeake Society (1988), and From Calabar to Carter's Grove (1997). Raymond Williams has referred to this type of collaborative effort as a "theory of social totality."²⁰ In the past, probate records were primarily used to illuminate how elite white men lived and died. Now with the theoretical

¹⁹ Paul Shackel, Personal Discipline and Material Culture: An Archaeology of Annapolis, Maryland, 1695-1870 (Knoxville, 1993) 144-150. Shackel described the social contexts of using specific goods when dining. In order for the elite to maintain their position, daily activities such as dining emulated what was considered "proper conduct" in Europe.

²⁰ Cary Carson, Ronald Hoffman, and Peter J. Albert, eds., Of Consuming Interests: The Style of Life in the Eighteenth Century (Charlottesville, 1994). This volume looks specifically at consumption patterns from various disciplines. See also Philip Morgan, Lois Green Carr, and Jean Russo, eds., Colonial Chesapeake Society (Chapel Hill, 1988). This volume concentrates on various aspects of colonial society. In From Calabar to Carter's Grove, Lorena Walsh uses material culture studies, archaeology, genealogy to trace the social development of an enslaved African community. Raymond Williams quoted in Gary Nash's "Social Development," in Jack P. Greene and J. R. Pole, eds., Colonial British America: Essays in the New History of the Early Modern Era, (Baltimore, 1984) 235.

approach of social totality, “a foundation for the development of a new, more inclusive framework for the reconstruction of colonial history” has been realized.²¹

“This, My Last Will and Testament”: The Social Implications of Death

In the year 1707, nineteen-year old John Timson wrote his last will and testament:

...being sick and weak of body but sound and perfect and disposing mind and memory praised be God...and given and considering the uncertaintys of this transitory like and the great nature made by almighty God in heaven that it is appointed for men one to dye...this my last will and testament...First I resigne my soule unto the hands and protection of God almighty may pardon and full remission of all my sins and to inheritt eternall life my body I committ to the earth to be decently intorred...my executor hereafter nominated and as touching my temporall estate my debts and funerall expences...²²

Timson was a wealthy, young, native Virginian who was studying in England. He owned land and enslaved Africans. Timson was a member of an influential and established York County, Virginia family. Thus his assets and material possessions needed to be properly distributed among his family.

Through wills, an individual often related personal feelings, how he/ she valued particular material items, and the type of personal relationships he/ she had with kinfolk, friends, and business associates. Wills provide evidence for rare personal sketches of the deceased through documents that were within the public domain. A will also provided a window into several aspects of an individual’s personality. People often indicated their religious beliefs, specific instructions to be

²¹ Jack P. Greene and J. R. Pole. “Reconstructing British-American Colonial History,” in Jack P. Greene and J. R. Pole, eds., Colonial British America: Essays in the New History of the Early Modern Era (Baltimore, 1984) 11.

carried out at their death, and other personal information they wished to become public knowledge. Those who left detailed wills and had room-by-room inventories taken of their possessions were often members of a group of colonial men and women who needed to record their wealth. “[O]ne of the most obvious weaknesses of a sectoral approach to historical and social analysis” noted Jack Greene and J. R. Pole, was “the difficulty of tying various sectors together and showing how through a series of complex interactions they operate to shape the historical and/or social process....”²³

Through the words and instructions of wills, every inheritance, family misfortune, marriage, and death also directly affected the enslaved African community. Although it is difficult to trace the individual lives of enslaved Africans, Lorena S. Walsh pointed out that when planters distributed enslaved men and women, “most slave owners were just as careful to delineate collections of human property as they were to itemize the descent of particular parcels of land.”²⁴ This particular case study was done on a much smaller scale than Walsh’s Carter’s Grove study. Yet having looked at two specific families, some semblance of the lives of enslaved men and women owned by the two families was possible. Each member of these families participated in a society that had become dependent on slavery, and as the families grew and prospered, faint images of the enslaved community have come to light. Their stories are also included in the following chapters.

²² York County Deeds, Orders, and Wills (13) 239-40 recorded 2 April 1707.

²³ Greene and Pole, “Reconstructing British-American Colonial History,” *Colonial British America*, pg. 10.

²⁴ Walsh, *From Calabar to Carter's Grove*, pg. 6. Walsh avoids the problem of tracing individuals and families and traces groups of slaves over time. “Multigenerational group histories offer a promising middle ground between the general and impersonal and the handful of recoverable, probably atypical, individual or family histories.”

The verbatim accounts left in wills and inventories do not create a fluid history, but the methods that have been used here have helped to create a narrative that personalizes individuals through visual cues. A dwelling, the objects carefully placed inside a house, and how space may have been used, have provided social and economic profiles of ordinary people. Without diaries or personal letters, the historian of this time period has a difficult task. Yet through probates and inventories, patterns of consumption has revealed the ways a society placed value on both people and other forms of property.

Historical interpretation is not static. The truth is not the final product of historical analysis, instead interpretation is but one of many truths that become part of the larger discussion of our understanding of the distant past. Henry Glassie describes history as a form of myth: “All art, including history, obeys generic rules and uses small lies to approach large truths. All human products, including the facts out of which history is constructed, are available to intelligent discourse but not to final knowing: their truth lies always just beyond.”²⁵ The narratives of Robert Crawley and Samuel Timson involved a variety of characters, all of whom contributed in their own ways to the historical myths of a transitional period in colonial history.

²⁵ Henry Glassie, “Meaningful Things and Appropriate Myths: The Artifact's Place in American Studies,” in Robert Blair St. George, ed., Material Life in America, 1600-1860 (Boston, 1988) 64.

FIGURE 1: ROBERT CRAWLEY

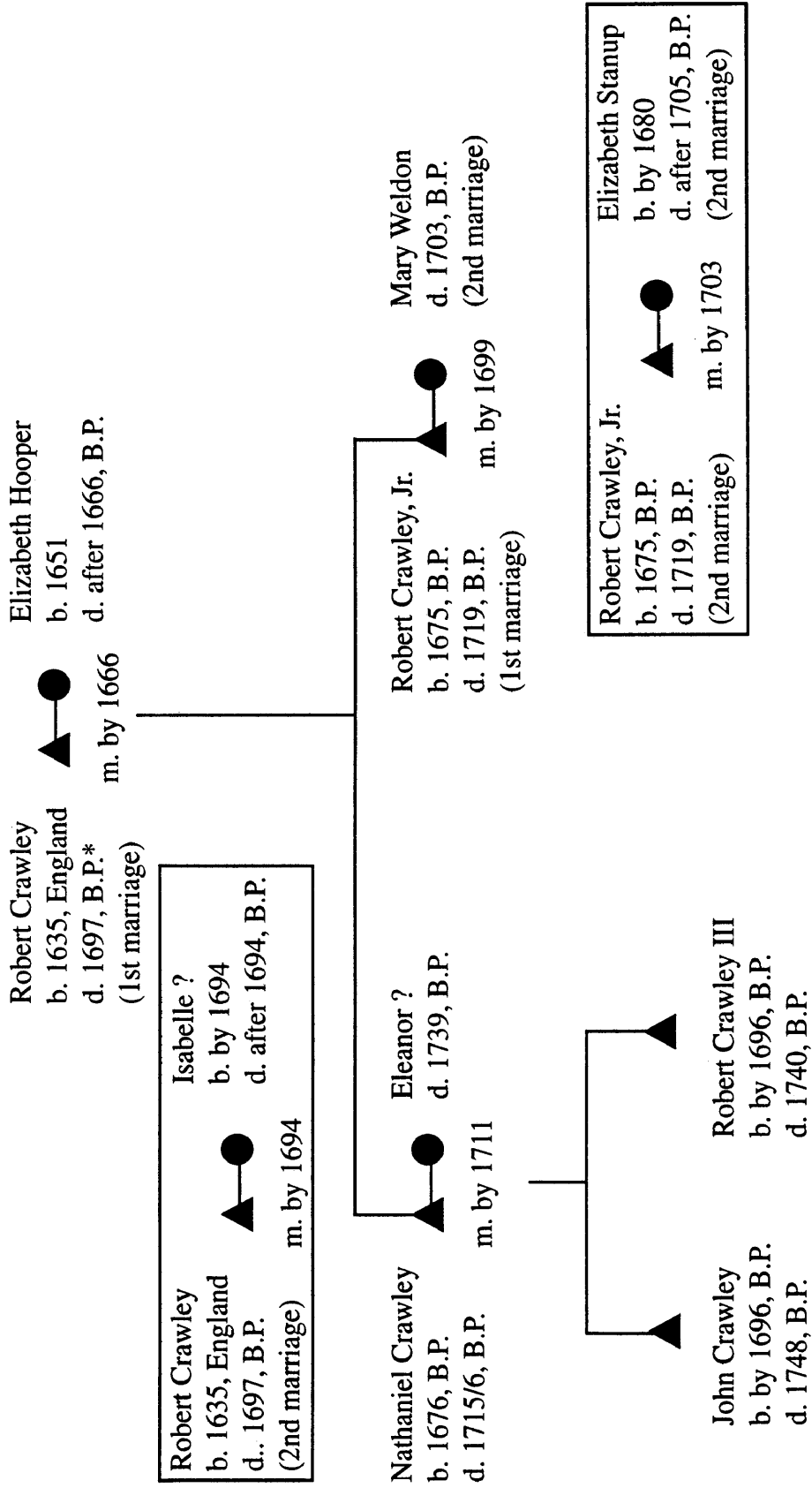

* Unless otherwise noted, "B.P." refers to Bruton Parish, York County.

FIGURE 2: ROBERT CRAWLEY III

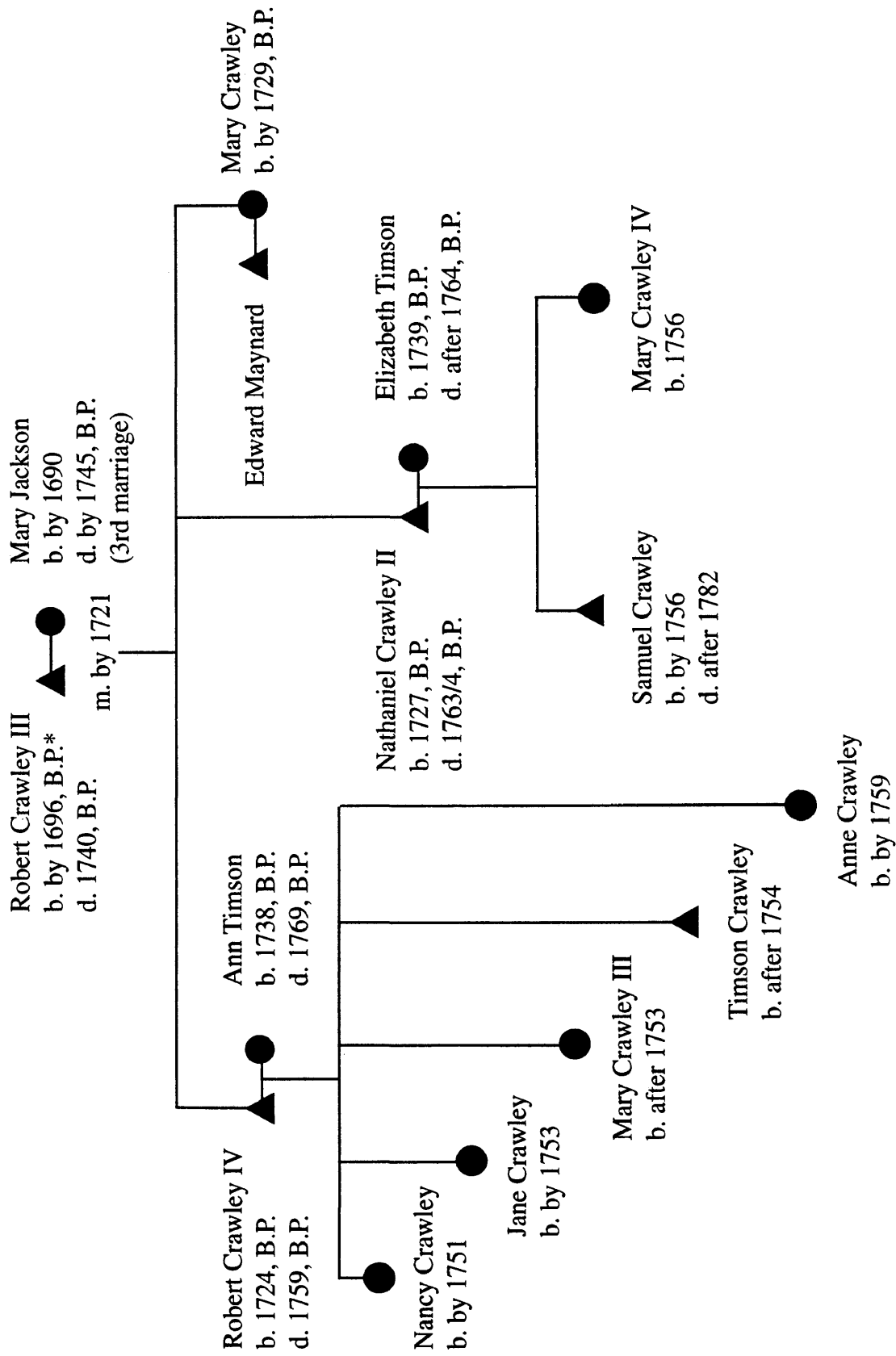

* Unless otherwise noted, "B.P." refers to Bruton Parish, York County.

FIGURE 3: JOHN CRAWLEY

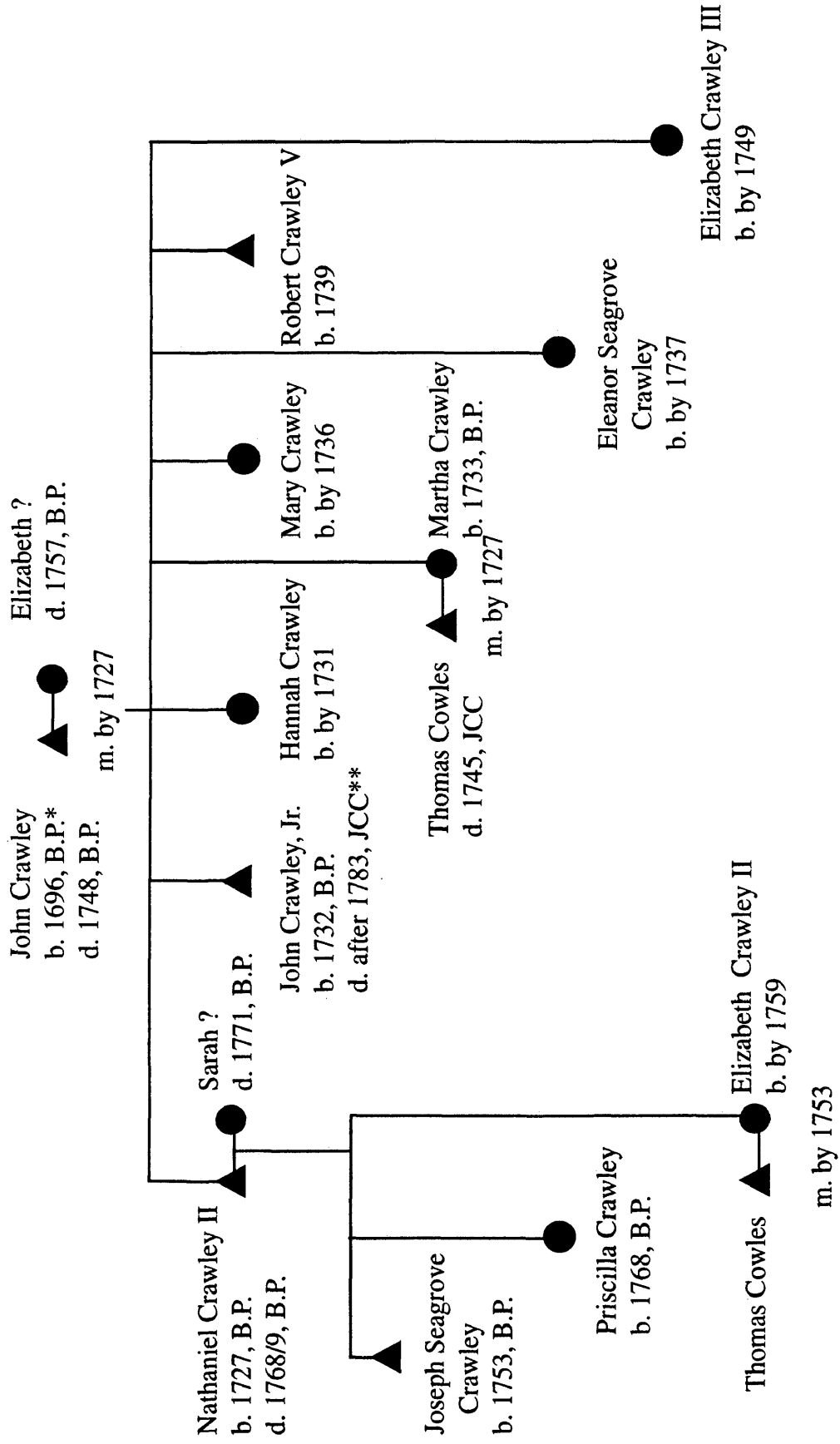

* Unless otherwise noted, "B.P." refers to Bruton Parish, York County.

** Bruton Parish, James City County.

CHAPTER III

THE CRAWLEYS

The Crawleys were one of the many struggling families who, through hard work, solid investment, and strategies that ensured upward mobility, survived the early colonial period. The analysis of three generations of the Crawley family attests to the fact that freeman and lower classes were able to achieve the basic elements of economic success and social importance similar to that of middling and upper class families in places like York County, Virginians. Robert Crawley, once an indentured servant, over time became the patron of an influential and powerful York County family. The chronicling of the Crawleys' inventories, probates, and wills creates a narrative of their lives: the decisions they made, the structure of their households, their growing dependence on enslaved labor, and the legacy they left.

More than 20,000 people emigrated from the shores of Great Britain to the coastal colonies of the Chesapeake Bay region during the seventeenth century. Robert Crawley was one of the individuals who chose the Virginia colony as a place to begin a new life. Historical documents leave behind no accounts or personal testimonials that point to the reasons why Crawley left England. This also makes it difficult to imagine the life Crawley left behind in his native country, the opportunities he may have believed awaited him in Virginia, or what he thought life in the colony would

have been like for him. The colonial saga of Crawley can, however, be imagined through the events of the era within which he arrived to the Chesapeake.

Around the year 1660, the Virginia colony began what Jack P. Greene described as a “profound social transformation.”¹ Between 1660 and 1670, immigration took a new form: those who emigrated to the coastal colonies of Virginia and Maryland were not the same as their predecessors. Virginia’s dependency on tobacco produced an insatiable need for workers. During this early period of economic growth, the most common immigrant class consisted of young, single, British men, many of whom could not afford their passage and thus ended up bound to a fixed contract and period of service in return. This class of colonists was highly mobile and arrived with few kin relations or ties to any particular community. The unstable aspects of life for a majority of the population in the southern colonies during the mid seventeenth-century created an environment of unbalanced sex ratios, high mortality rates, economic inequality, political disunity, and a weak social structure.² This was the world of Robert Crawley.

Robert Crawley: From Indenture to Freeman

Robert Crawley was born in England around 1635 and ventured to the New World in his mid-thirties. Leaving England was a positive alternative to what a majority of English faced in their homeland; this may have been the case for Crawley.³

¹ Greene, *Pursuits of Happiness*, pg. 81.

² *Ibid*, pg. 82. Greene points out that the demographic makeup of English immigrants in the early part of the century were predominately young, single males. The population began was growing, yet was distinct from other regions on the eastern seaboard of Massachusetts, Maryland, and Delaware.

³ Horn, “Servant Emigration,” pp. 51-95. Horn’s article touches on some of the origins of many of the thousands of English immigrants that chose to leave England for the Chesapeake colonies. Dispelling

Crawley arrived in Virginia no earlier than 1665/6. His name appeared on a land certificate issued in 1665/6 and in which he was sponsored by Lt. Col. Thomas Beale, of Virginia. He experienced the long and arduous journey along with fifty-eight other English men and women, possibly with similar thoughts of opportunity and chances for social and economic mobility in the colony.⁴ The sponsorship of his venture sealed him to a binding contract and may have been the only way for him to come to Virginia. It was likely that he was virtually penniless and began his new life in the colony with a debt in the form of an indenture to either Lt. Beale or another colonist who needed labor.

Robert Crawley may have married soon after he arrived in the colony. York County Records indicate that Crawley was married to a Virginia-born woman named Elizabeth Hooper by the year 1666. There was no record of the couple's marriage in Virginia and Elizabeth appears as an orphan, cared for by Nicholas Cummings, in Virginia by September of 1666.⁵

The Crawleys began their family nine years after they were documented as being husband and wife. The couple had their first child, Robert, in 1675 and their second, Nathaniel, in 1676. Crawley's early years in Virginia were a mystery. He left no record of where he or his family lived during a period of twelve years, and there

the myths that those drawn to the Chesapeake coast were "riff-raff", Horn finds documentary evidence pointing to those who emigrated as most likely middling farmers and skilled workers. A great deal of them left due to harsh conditions in England stemming from a sharp increase in population, dropping wages, and increased unemployment. Land and possibilities of prosperity were becoming non-existent and in the Chesapeake hard work seemed to include unheard of opportunity.

⁴ York County Deeds, Orders, and Wills (4) 51 recorded 26 Feb 1665/6. Certificate is granted to Lt. Col. Thomas Beale for 2,950 acres of land for the importation of 59 persons into the colony [viz]: William Beale, William Jones... **Robert Crawlie** [sic]...

⁵ There is no indication of Elizabeth Hooper's age when she is called an orphan in 1666, but it seems as if her status as an adult and a married woman would have changed during this time. Based on looking

was no record of his having rented or purchased property in or around York County. Elizabeth died shortly after the birth of Nathaniel, sometime between 1676 and 1678, leaving no will or probate.

Soon after, Crawley's possible seven-year indenture ended, and within eleven years of his arrival, he acquired 200 acres of property in 1678.⁶ Approximately a year later he remarried a woman named Isabelle. The rigors of colonial life would have profoundly disrupted family structures; it was therefore common for men like Crawley to have quickly remarried.⁷ There was no indication of Isabelle having been married before or having children from a previous marriage. Robert and Isabelle had no children of their own, but remained together until Crawley's death in 1697. When Crawley acquired the 200 acres, he also began to establish a small farm and labor force of two young boys, one an English servant and the other an enslaved African. He appeared in York County Court in 1679/80 and attested to a binding contract of a young English indentured servant named Edward Giles, who was then eleven years old.⁸ Nine months later, in October 1680, he appeared in court again to have the justices of the peace determine the age of a young enslaved African named Jack. The

at other guardian accounts from the Timson and Crawley family, it seems as if women are removed from the care of their guardians only when they are married.

⁶ York County Deeds, Orders, and Wills (6) 550 recorded 24 Jan. 1683/4. Grantor: Humphrey Symonds and wife Anne. Grantee: Robert Crawley; Date: July 6, 1678; Recorded Jan 24, 1683/4; Acres: 200; Price: "valuable satisfaction"

Bounds: being part of and belonging to eight hundred and fifty acres of land granted by patent bearing date March 28, 1664 into Richard Vardy...Crawley not to molest or hinder the sd. Toope, but to enjoy the rents or profits from the sd. lease.

⁷ Darrett B. Rutman and Anita Rutman, *A Place in Time: Middlesex County, Virginia, 1650-1750* (New York, 1984). The Rutmans use vital statistics, probates, wills, and inventories to create a complete picture of the importance of death in the lives of colonial Virginians. Death was a very real aspect of life for colonial settlers. Through fictive kin, guardians, siblings, second and third marriages a structurally complex social system developed.

⁸ York County Deeds, Orders, and Wills (6) 178 recorded 26 Jan 1679/80.

magistrates judged that Jack was eight years old.⁹ With 200 acres of land, two sons from his first marriage, and a small labor force, Crawley continued to establish his economic mark in the colony. By 1683 Crawley purchased an adjoining 200-acre tract of land from Humphrey and Anne Symonds, which doubled his landholdings.

Robert Crawley's investments never reached far beyond his homestead. Crawley's inventory showed no indication of his depending solely on tobacco production. He may have grown a limited amount of tobacco, but his primary concern would have been a variety of crops to feed his household. The word gentleman never followed his name, nor did he become actively involved in colonial political life. Based on some of the items in his inventory, he may have been a part-time tanner or leatherworker. His abundant supply of leather, tanned and raw hides in conjunction with several specialized tools indicate his occupation. A man who had a small farm and even smaller labor force may not have had the markings of a gentleman, but supplementing his income with leatherwork would have allowed him to have some limited community ties through local trade.

After Crawley's death in 1697, the appraisers of the estate listed three enslaved Africans: one female, one male, and a three-year old child. The man appears to be "Jack," purchased in 1680. Jack would have been twenty-seven years old when Crawley died.¹⁰ The York County records did not indicate when the enslaved woman was purchased. It is difficult to create a profile with details of her life without even knowing her origin. The missing date when the woman arrived on the property, the

⁹ York County Deeds, Orders, and Wills (6) 255 recorded 25 Oct 1680. Jack a Negro boy servant to Robert Crawley, adjudged 8 years old and ord. to pay levies for him until he attain age 12.

¹⁰ York County Deeds, Orders, and Wills (11) 19-20 recorded 3 March 1697/8. The inventory indicates that Robert Crawley possesses a Negro man and his bed at a value of £27.

price of her purchase, and her age when Crawley died points to the possibility that she was an adult when Crawley purchased her. The assumption that the enslaved child listed in the inventory is the son or daughter of Crawley's enslaved female may also mean that she would have been at least over the age of sixteen.¹¹ When Giles' indenture was completed, Crawley may have made the decision to purchase an enslaved African instead of another English servant. A woman may have seemed to Crawley to be the best choice, for owning an enslaved family had economic advantages for Crawley. With an English servant such as Giles, the term of labor would eventually have come to an end. With Jack or the enslaved woman the period of service was permanent. In addition to the lifetime of work of an enslaved laborer, the possibilities for reproducing the labor force must have always been in the minds of colonial farmers and planters.

There was no indication of a distinct physical separation between the three enslaved Africans living on the farm and the Crawley family. Crawley may have just begun to clear the land and build structures on his property when he died. The 200 acres purchased from Symonds was a part of a larger parcel of 850 acres, and may not have been as easily improved as his original 200-acre tract.

The only glimpse into the lives or possessions of Crawley's enslaved Africans was their bedding, listed beside them in the inventory. Without a detailed account of any additional or supplemental buildings on the property, there was strong evidence that they may have lived in the Crawley house or a dwelling not too far from the main

¹¹ Walsh, *From Calabar to Carter's Grove*, pp. 88-89. Walsh points out that African-born women were slower to have children, this is indicated by the adult/child ratios present in her study of the beginnings of the Carter's Grove plantation outside Williamsburg, Virginia. Creole slaves had larger families (having children who survive infancy) by women who had been the colony for at least twelve years.

Crawley home. Camille Wells states that appraisers often found little need to list possessions owned by enslaved people; other historians interpret the absence of goods owned by enslaved Africans in the inventory or his/ her owner as an indication that the enslaved owned the goods (clothing, cooking utensils, etc.).¹²

In the late seventeenth and early eighteenth centuries, small to middling farms such as Crawley's would have had neither the resources nor the necessity to separate their work force from their families. Planters of Crawley's status had small compact farms in which both the laborers and family members would have shared the work. The master and his family would have worked in close proximity to their enslaved laborers, often side by side during planting or harvesting season. The Crawley household was an example of small farmers who worked, lived, and socialized with their enslaved laborers without a distinct physical or social separation due to race or status.¹³

As Crawley's livestock, family, land, and wealth grew, it was likely that he would have needed more assistance in the daily running of the farm. The presence of an enslaved male, female, and child indicates that Crawley created an environment that encouraged the development of family ties on his farm. His shift to enslaved laborers also established a greater sense of economic stability for him. The enslaved

¹² Camille Wells, "New Light on the Sunnyside: Architectural and Documentary Testament of an Early Virginia House," Bulletin of the Northumberland County Historical Society 32 (1995): 3-26. Wells describes the difficulty of assessing material of the enslaved on plantations due to probate appraisers feeling the property wasn't worth anything.

¹³ Morgan, American Slavery, American Freedom, pp. 154-155. Morgan discusses how racial feelings in the early seventeenth-century were directly linked to the social position of Africans, but there was initially some indication of Africans potentially becoming contributing members of colonial society. Also, pp. 310-315, Morgan goes on to describe how in the 1660s there were more clearly defined social and legal lines drawn along racial lines. In 1676 Bacon's Rebellion in 1676, white servants and enslaved Africans were physically separated. But in the case of a small farm like Crawley's the physical separation may not have seemed as important as a larger plantation or farm.

woman would have assisted Isabelle Crawley and the family in dairy production and the domestic needs of the household, as well as farm-related chores. Neither Edward Giles nor any other English servant appeared on the inventory, indicating that Crawley began to depend on enslaved African labor. As stated earlier, the initial expense of purchasing enslaved Africans was usually too high of expenditure for farmers of Crawley's initial standing. Crawley's ability to purchase not one, but two enslaved Africans reveals that Crawley's economic status had steadily increased over time.

Crawley probably died unexpectedly. In any event, he left no will. His inventory indicated a discernable pattern of consumption that showed Crawley's patience and discipline in how he spent money, and possibly how he used his time. The book Robert Cole's World offers a comparable description of a cautious tobacco farmer in the upper Chesapeake region of Maryland. Cole's profile helps in understanding the possible mindset of someone like Robert Crawley. Cole was in charge of all administrative and household decisions and his actions likely "...encourage[d] caution and the conservation of the estate rather than a more aggressive- and riskier- effort to grow."¹⁴ Likewise, Crawley's wealth included few amenities, perhaps a reflection of Crawley's self-sufficient and careful household management. Like Cole, he seemed to have been uninterested in unnecessary expenditures, yet never having neglected the overall comfort of his family.

Crawley's 1698 household inventory provided an overall impression of the state of his residence. The inventory was not prepared on a room-by-room basis, but the items seemed to have been grouped in association with where they may have been

¹⁴ Lois Green Carr, Russell R. Menard, Lorena S. Walsh, Robert Cole's World: Agriculture and Society in Early Maryland (Chapel Hill, 1991) 90.

used. The way in which the items were grouped suggested that Crawley lived in a common two-room structure where items were kept wherever they were needed. In the common rituals of the Crawley home, all of the space was clearly utilized with great efficiency. He owned an assortment of tools that reflected the types of activities which took place there. Examples of household production are indicated by his parcel of shoemaker's tools, a cheese press, and twenty-two milk pans.¹⁵

Crawley possessed some amenities for entertaining neighbors and guests. He owned two tables: one long table and a round table with six chairs. These items likely served several functions, and the distinction between dining space, workspace, and sleeping space was probably not very pronounced. Robert Cole, who died in 1662, left an account of his seventeenth-century hall and parlor house that appeared to have a similar floor plan to that of the Crawley house.¹⁶ Crawley also owned seventeen pewter dishes, fifteen plates, a silver tumbler, and the necessary equipment to indicate a kitchen that would have produced a variety of meals for family and guests.

Although the décor of the Crawley household was simple, it showed some elements of care in its presentation. He owned window curtains and valances, candlesticks, a flowerpot, and a looking glass (mirror). Bedding was an indication of the desire for personal comfort. Crawley had four feather beds, an additional candlestick, two chamber pots, a "wainscot" couch, and a warming pad. All of these items would have created certain accents to the rustic appearance of the interior of the house, and testimony to the changing lifestyle of middling farmers.

¹⁵ See Appedix A. Inventory of Robert Crawley, DOW (11) pp. 19-20.

¹⁶ Carr, Menard, and Walsh, Robert Cole's World, pp. 93. Robert Cole's house is described as containing a hall or parlor that was often used as a second room and was also referred to as the kitchen.

An oddity of the Crawley estate was the 1698 inventory's description of "Mr. Crawley's library." There were no books listed, but there was "a slate" valued at two shillings. Items such as these suggest that the Crawley sons were taught reading, writing, and mathematics at home.¹⁷ Other non-essential items appearing in the inventory points to leisurely activities. Late in life Crawley likely established a home environment for his family that indicated the social prestige he acquired, as he grew more financially secure. The library is also the only time that the title "Mr." was ever used in reference to Robert Crawley.

Robert Crawley's arrival in Virginia was of little note, but he survived and worked hard, and planted the foundation that all his descendants would have benefited from. When he died he was a landowner with a sizeable plantation. He had acquired items of luxury, such as rush chairs, a looking glass, candlesticks, and a dressing box. These items would have initially been out of reach to a struggling farmer. His frugality and common sense made him a success as a Virginia planter.

Nathaniel Crawley: Second Generation Freeman

Robert Crawley, Jr. and Nathaniel Crawley experienced a very different Virginia than their father had known when he first came to the colony in 1665/6. The Crawley sons exercised a certain level of privilege and accomplishment that their father had only begun to realize near the end of his life. They were associated with the land holding members of the community, were active political constituents, and

It most likely functioned as a kitchen/ workspace and was free of beds, yet containing tools and other objects used for sitting or dining.

¹⁷ York County Deeds, Orders, and Wills (11) 19-20 recorded 3 March 1697/8. A slate listed in "Mr. Crawley's library" is valued at 2 shillings.

participated in the county's economic market, Importantly, they were also members of the slave holding class.

Robert Crawley Jr. was the first son born to Robert and Elizabeth Crawley in 1675. He was active politically and socially throughout his life in York County. He held positions such as vestryman, juror, auditor, jury foreman, and constable. In 1705, at the age of 29, Robert Jr. purchased 860 acres of land. His inventory also listed several luxury inventory, along with a sizable labor force of enslaved Africans, all of which indicated his position as a middling farmer. Crawley Jr. was a colorful character. He was married twice and was also brought to court for having an extramarital affair that produced an illegitimate child with Katherine Dean of Yorkhampton parish in York County.¹⁸ How his peers perceived him is unclear, but his political life suggests that overall he received some level of respect among his contemporaries.

Nathaniel, the youngest son of Robert Crawley, was born in 1676 and would have thus been a young man when his father died. Although there was no legal document that specified the amount of land left to him by his father, there was a strong possibility that he had reached adulthood with some land. Nathaniel and Robert, Jr., however, had already established themselves in York County when their father died.

Nathaniel Crawley married a Virginian-born woman from Bruton Parish named Eleanor. The couple had two sons. The dates of their birth were not recorded, but they were born after 1696. John appeared to have been the oldest, followed by Robert III. There is a large gap in the public documentation of Nathaniel Crawley's

life between the time he served as co-administrator of his father's estate and his death. Based on the information provided by these few documents, there was no solid evidence that described Nathaniel's occupation. His name simply appeared in court when he died in 1717 at the age of forty-one.¹⁹ Fortunately, Nathaniel left a will and a detailed inventory that were extremely helpful in understanding his social position and how he displayed it through the items in his household.

The importance of personal appearance stood out in Nathaniel's inventory, as did decorative items and elements of rustic elegance. He owned a variety of fine and specialized items; his wardrobe indicated a man with more fashion and grooming needs than that of the average craftsman or yeoman planter who worked the land. A sample of the clothing listed in his inventory included:

- 3 Wigs
- 1 brush, 1 small brush
- 3 dozen horn buttons, 4 dozen small breast buttons
- 2 druket britches, 17 mohair handkerchiefs
- 1 coat, 1 searg. Frock, 1 druket coat
- 1 fine hat, 3 neckcloths, 2 silk handkerchiefs
- 8 lining handkerchiefs, 5 shirts
- 2 pr. Of shoes, 2 pr. of silver buckles, 2 pr. of garters
- 1 pr. Of ticking britches, 1 silk camlet frock
- 1 belt, 1 silver breast buckle
- 1 pr. of lining stockings, 1 pr. spit boots

Nathaniel's house was a common hall, chamber, and kitchen plan with a large number of amenities throughout the house.²⁰ The analysis of the inventory points to

¹⁸ York County Deeds, Orders, and Wills (13) 238 recorded 25 July 1709. In info brought by Charles Collier churchwarden of the upper precinct of York Hampton Parish in this county against Katherine Dean for having a bastard child.

¹⁹ York County Deeds, Orders, and Wills (15) 116-117 dated 19 Dec 1711 and recorded on 20 May 1717.

²⁰ Cary Carson, Norman Barka, William Kelso, Gary Wheeler Stone, and Dell Upton, "Impermanent Architecture in the Southern American Colonies," *Winterthur Portfolio* 16 (1981): 135-196. There are

the “kitchen chamber” functioning as sleeping quarters for his English servants and enslaved Africans as well as a workspace. Nathaniel and his wife would probably have slept in the Chamber room fully equipped with a feather bed and all the trimmings. His oldest son may have slept in the small garret over the hall, which also contained a feather bed and all of the trimmings. A sample of the items in the kitchen chamber above the common kitchen included:

- 1 featherbed & bolster, 1 rug, 1 pr. of blankets
- 2 pr. of sheets, 1 bedstead & Cord
- 1 Servants bed & bedstead
- 1 small trussill bed, 1 rug, 4 pr. cotton blankets
- 1 pr. of Virginia Cotton Sheets
- 2 large falling tables
- 1 dozen Rush leather chairs and 4 small old chairs
- 1 old trunk, 1 sealskin trunk, and 1 small box
- 2 Looking glasses

The various items that indicated the types of activities which took place in and around the household did not put Crawley in the same category as a large plantation owner. The size of the property and his labor force, however, would have allowed Nathaniel to pursue leisurely activities. For example, his inventory noted that he owned a Bible, a testament, one primer, and eight old histories. This items not only indicated some formal education for Nathaniel, but also a household where parents taught reading, writing, and religion to their children.

Nathaniel’s inventory demonstrates a more prestigious lifestyle than his father’s. Unlike his father, there was no heavy reliance on strictly utilitarian vessels. In addition, the items in his inventory attested to Nathaniel’s privilege of having a variety of interests. He owned guns, a sword, a breastplate, and various specialized

several different types of house plans used at the end of the 17th and beginning of the 18th century. Nathaniel’s house may have been a two-story house with 4-6 rooms.

bridles and harness equipment. These items strongly suggest military training or participation in the local militia. He also possessed money scales, a mortar and pestle, and several alchemist spoons. These could have been associated with his having been a merchant or businessman.

It is also possible is that Nathaniel was a tavern keeper or a lodging-house keeper. Evidence of this is reflected in items associated with entertainment. Nathaniel seemed to spare no expense in the décor of his house. There were tablecloths, napkins, mugs, different types of plates and bowls, rugs, brass candlesticks, playing cards, and curtains. The Crawley household invested heavily in the purchase of non-essentials. Being a merchant or tavern keeper may explain why these items were scattered throughout the family home.²¹

Nathaniel's inventory indicated many different products that were possibly manufactured on the property. There was a spinning wheel, an indication of wool or other fabric production, leatherworking tools, cider making equipment, and a variety of livestock indicating some level of animal husbandry. A farm with items associated with animal husbandry, low-scale household clothing production, and agricultural tools translates into Crawley's ability to rise above his father's necessity to work the land for survival. Nathaniel had moved beyond self-sufficiency.

There was no record of Nathaniel buying property in York County, so he probably continued to maintain the Phatan plantation, a piece of property most likely given to him by his father in James City County (no record of this exists in York

²¹ Lois Green Carr and Lorena S. Walsh, "Changing Lifestyles and Consumer Behavior in the Colonial Chesapeake," in Ronald Hoffman, Cary Carson, and Peter J. Albert, eds., Of Consuming Interests: The Style of Life in the Eighteenth Century (Charlottesville, 1994) 65-69. Carr and Walsh describe how the

County). However, Nathaniel most likely lived in York County since his will and inventory were recorded in York County. He therefore must have had land and a house in York County. One last, curious note: there were two inventories taken of his household. An itemized one, and one labeled the “true” inventory of his estate. Eleanor Crawley, his widow, seemed to have been the only witness for the second “true” inventory.²²

Nathaniel employed a labor force of six individuals, including five enslaved Africans and one English servant, and there was no direct reference to a separate dwelling on the property. Interestingly, all of the enslaved Africans were listed separately before any of the room by room inventory was recorded. Undoubtedly, Nathaniel’s enslaved people lived in a separate dwelling from the main house. The emergence of separated spaces based on race started to take place in the colonial Chesapeake during this time period. Archaeologist Terrence Epperson pointed out that, “[s]everal architectural and archeological analyses have traced the processes of spatial differentiation and specialization within Virginia plantations during the last half of the seventeenth century and the first quarter of the eighteenth century.”²³

“sameness” of the seventeenth-century changed as all members of colonial society began to want non-essential items in their homes.

²² York County Deeds, Orders, and Wills (15) 123-124 recorded 20 May 1717 and inventory and appraisal in *Ibid*; recorded 16 September 1717. Not all of the items in Crawley’s inventory recorded in May 1717 appear in the inventory and appraisal that was recorded in September 1717. This may point to some dissatisfaction of how the inventory was appraised and may also have affected the distribution of the estate among the heirs. With Crawley’s position, the need to have an accurate account of his possessions at death would be of greater importance and symbolize the increasing importance of material and human possessions.

²³ Terrence Epperson, “Constructing Difference: The Social and Spatial Order of the Chesapeake Plantation,” in Theresa A. Singleton, ed., “I, Too, Am America”: Archaeological Studies of African-American Life (Charlottesville, 1999) 165. Epperson gives four detailed examples of how the increase in enslaved Africans in Virginia led to a number of social and political changes in the colony. One in particular was the arrangement of space and the separation of white and black people throughout the eighteenth century.

The labor force that lived on the property consisted of three adult men (Will, Robin, and Tom), one adult woman (Cate), and an English servant named John Barbar. There was also one child, described as “young Hannah.” The lack of documentation regarding how or when the enslaved Africans or Barbar had come to the plantation made the possibility of determining if families were established families difficult. John Barbar was the only person listed in the inventory as living inside the house, this also points to the racialization of living quarters on the Crawley property. Barbar was listed with his bed and bedstead with the items in the kitchen chamber, where he likely slept.²⁴

Nathaniel owned more than one tract of land, but if he distributed his labor between the two properties or this was never recorded. With this small labor force, the chances of the Crawley family and its laborers to work and interact closely with one another may would have been different than had been the case with Robert Crawley, Sr., and his family. Although Nathaniel would not have worked side by side when crops were planted or harvested, he most likely would have had frequent contact with each member of the farm. His duties were more diversified than that of a small farmer, but with only six laborers, daily interaction still allowed for a certain level of intimacy.

Nathaniel acquired a great deal more personal property than his father. In his will both sons received a considerable inheritance. All other property, possessions, and livestock were to be divided equally between his wife and sons. This was not a common stipulation in wills of the early eighteenth century. Although Nathaniel’s

²⁴ York County Orders and Wills (15) 165-166. Recorded 15 July 1717. In the kitchen chamber there is a listing of “1 Servants bead and bedstead”, this is most likely the placement of John Barbar

wife would not have received land directly, she would have still benefited from her late husband's estate, which allowed her to live out her life comfortably whether she was remarried or not.

Eleanor never remarried and died more than twenty years later than her husband in 1738. She left a will that gave her sons and granddaughter the remainder of her estate. Because of the property left by her husband, she was allowed to live comfortably and independently. Interestingly, she also left to her enslaved African woman, described as her "mulatto wench," all of her clothing. This was an intriguing detail that was absent in all of the other wills left behind by the Crawley clan. Why Eleanor would have done this may never be known. But the unnamed woman may have been a seamstress or have had a skill that indebted Eleanor in such a way that she wanted to give her items that would have set her apart from the other enslaved men and women owned by the Crawleys. This was, however, rare example of the contrasting ideals of the slave society that had become an integral part of colonial life in Virginia.

Whatever his occupation or the impact his life had on the larger community, Nathaniel had begun to set a standard of living for the future generations of Crawleys to follow. The struggles of Robert Crawley would have been a thing of the distant past. The necessity to work the land for long and hard hours ended. All of the later Crawleys started their lives with some degree of privilege and advancement greater than Robert Crawley could have ever imagined. In line with his contemporaries, Nathaniel realized the significance of owning enslaved Africans. He was the first

described as an English servant.

Crawley to establish a working plantation dependent on enslaved labor. The separate and racialized spheres of black and white had become a part of the landscape as well. Based on Nathaniel's example, Crawley descendants were in a position to perfect the practice of gentry slaveholders.

John Crawley: The Changing Status of a Planter's Son

John was an example of the successes of his father and grandfather's economic achievement. He was the older of the two sons born to Nathaniel and Eleanor Crawley sometime around 1696. He was a member of Bruton Parish church and continued his father's political and social responsibilities. John started his life with property in James City County, a few enslaved Africans, as well as other items owned by his father. He married a woman named Elizabeth, who left behind no record as to when or where she was born. The family by now had become established as upper level, middling farmers with land and enslaved Africans. Elizabeth would most likely have been of a similar social standing and background when she married John. She apparently brought no property to the marriage.

The third generation of Crawleys began their family soon after marriage. In 1727, when John was about thirty, the couple had their first son, Nathaniel II. John and Elizabeth Crawley had six more children: Hannah in 1731, John in 1732, Martha in 1733, Mary around 1736, Eleanor Seagrove around 1737, and Robert in 1739. The family was a large one, and John's inventory reflected this. There are very few details of John's life in York County records. Fortunately, he left behind a detailed will and inventory that helped to create an image of his household, property, and devotion to

family. The inventory was not taken room-by-room, which adds to the difficulty of recreating a floor plan of the dwelling. However, the way items were grouped together may point to some of the activities that took place in a particular room. Within this structure the distribution of material goods would have given the impression to guests and visitors that the Crawleys had an adequate amount of space for the family. John Crawley and his family probably lived in the four to six room house in which he grew up. There were at least ten beds in the inventory, including full beds with bolsters, sheets, and bedsteads and cords. Also, there were a total of four chamber pots in the inventory, which may also indicate the amount of individual rooms occupied by family members.

There exists a possibility that John continued to maintain a tavern or inn as his father probably did. There were several rugs that would have been related to the private and public rooms of the house, as well as a number of tables and leather chairs, a desk with a chair, window curtains, a looking glass, a chest and at least two candle boxes. Items related to dining point to the Crawley family having enough equipment to have entertained visitors and guests with comfort and ease. The inventory listed a parcel of knives, forks and spoons, thirty-five pewter plates, earthenware, everyday dishes, glasses, towels, napkins, and tablecloths. The kitchen had all of the latest cooking equipment and serving items. For enjoyment, John owned two decks of playing cards and a violin. John's assets were in some ways reminiscent of his grandfather, Robert Crawley, Sr. He owned several items that added a level of comfort to his life but did not seem extravagant.

John was active in the political and social aspects of colonial society. He was a member of the grand jury, an executor of wills, and a witness for the York County court. He was also a man who held a substantial amount of land, and participated in agricultural production with a sizable amount of livestock and a labor force of twelve enslaved Africans. He was the first of the Crawleys to forego ownership of any English servants and his death in the 1740s reflected the permanent transition from interracial work groups to a system that had become dependent on enslaved labor.

John Crawley owned five adult men (James, James Jr., Peter, Sam, Paul), four adult women (Sarah, Judith, Judith Jr., and Cate), and there were also three children (Will, Abigail, and Harry).²⁵ What was interesting about this enslaved community was the fact that they were listed in two separate groups. The first group - James, James Jr., Peter, Sarah, and Will - were associated with tools and livestock. This indicated that they lived away from the immediate vicinity of the family house, or that there existed a crude separation of house and field laborers. With no record of age, one can only approximate the age ranges of enslaved Africans. In terms of Crawley's enslaved population, the monetary value on the inventory seems to indicate that James and Sarah were parents. James Jr. (named after his father), Peter (most likely over the age of 12), and Will would have been their children.

The second group of enslaved people was associated with mostly household and horse-related items. Given to the amount of horse-related equipment, John may have had stables for his horses and those of his guests and visitors close to the house.

²⁵ It is difficult to determine the ages of enslaved Africans based on probate inventories and primary documents left by planters. Some historians have used the monetary value of individuals to determine if they are above the age of 12-15 or over the age of 55-60. This is not an exact science, but does allow

The items associated with the second group may also indicate the proximity of the family house to the area where the enslaved workers who served the house resided. Also, because there were more individuals listed with this group, they may have lived in more than one location on the property. Again, based on listed monetary value, Sam and Judith seemed to have been the adults, while Paul, Cate, and Judith Jr. were most likely all over the age of twelve (and possibly not related). Abigail and Harry seemed to have been under the age of twelve.

The changing operation of a farm or plantation during this time period is apparent in the inventory as well. There seemed to have been a more defined physical separation between John Crawley and his labor force. As the enslaved community's numbers increased, it may have been not only practical, but socially expected for Crawley to institute a separation of his house from various dependencies.²⁶ The needs of an enslaved population appear in the inventory: several simple beds, items that were described as old or worn, and a large surplus of wool, yarn, thread, spun cotton, Irish linen, and a spinning wheel. There were also items that indicated sewing and repairing of clothes for more than was necessary even for the large Crawley family.

In 1748, Elizabeth Crawley appeared in court to have the will of her late husband renounced. According to the will she had received one of John's dwelling houses and two enslaved Africans. Elizabeth was dissatisfied with the provisions of the will, with the main problem being the manner in which the enslaved were

for some form of interpreting the range of age for various enslaved communities. See Kulikoff, *Tobacco and Slaves*, pp. 352-80, for references to determining age ranges of enslaved populations.

²⁶ Epperson, "Constructing Difference," pp. 163-170. Epperson traces the "process of spatial differentiation and specialization within Virginia plantations during the last half of the seventeenth century. He sees not only a sense of architectural beauty, but also a need to create distance and maintain dominance over enslaved populations.

distributed among the family.²⁷ Her complaint was heard and a new assessment and division of the enslaved was prepared for the next court. In the final assessment Elizabeth Crawley received four, rather than two, enslaved Africans and she repaid her three sons for their loss with four pounds to be divided between them. Also, each son then received only two of the enslaved individuals until their mother died.²⁸ This brief, family struggle indicates the importance of enslaved labor and how it was directly tied to the social and economic hierarchy of York County. Enslaved labor became the primary concern of colonists since economic stability had become dependent upon it.

John Crawley established the Crawley name as one of power and social standing. The strategies set by his grandfather would continue throughout the eighteenth century with later generations establishing themselves as members of the native-born elite. The Crawleys were a prime example of all of the promise and opportunity that so many young English men and women had immigrated to the Virginia colony to find.

Probate inventories are an invaluable resource to the contemporary scholar. Restating Lois Green Carr and Lorena S. Walsh, probate inventories can illuminate changing attitudes toward personal possessions, and the patterns of gain and inheritance, which had a direct affect on future generations. Examining three generations of one family offers a window on the larger society, revealing the daily

²⁷ York County Wills and Inventories (20) 138-139 recorded 16 January 1748/9.

²⁸ York County Wills and Inventories (20) 145 recorded 20 March 1748/9. This summarized the final agreement and the price of all the property involved. For further information concerning the process of Elizabeth Crawley's complaint refer to York County Records JO (1) pg. 168 and JO (1) pg. 179.

life and activities of ordinary people and providing insights into how wealth and property had changed hands.

The types of items in a house reflected a great deal about an individual's personality and his/her importance in the society at large. Having the space to house fine items, to serve guests and visitors, along with the ability to have separate structures for laborers, and a diversified farm signified success. Richard Bushman found that many middling farmers and planters acquired the proper accoutrements in order to create the air of gentility and refinement.²⁹ The private spaces of households set the stage for how one would have been perceived by society. The Crawley men understood the changing role of material items and how possession reflected one's social standing.

As the seventeenth century progressed, the role of upper middling planters included more than economic survival. Their economic and social strategies ensured that their children would have had a better chance of increased social standing and political power. The Crawleys were just such a family. In three short generations they secured their place as Virginia planters. The opportunities that brought Robert Crawley to the colony in the 1660s facilitated his acquirement of land and enslaved Africans, and ensured further prosperity to his heirs.

²⁹ Richard Bushman, The Refinement of America: Persons, Houses, Cities, (New York, 1992) xiii.

FIGURE 4: SAMUEL TIMSON

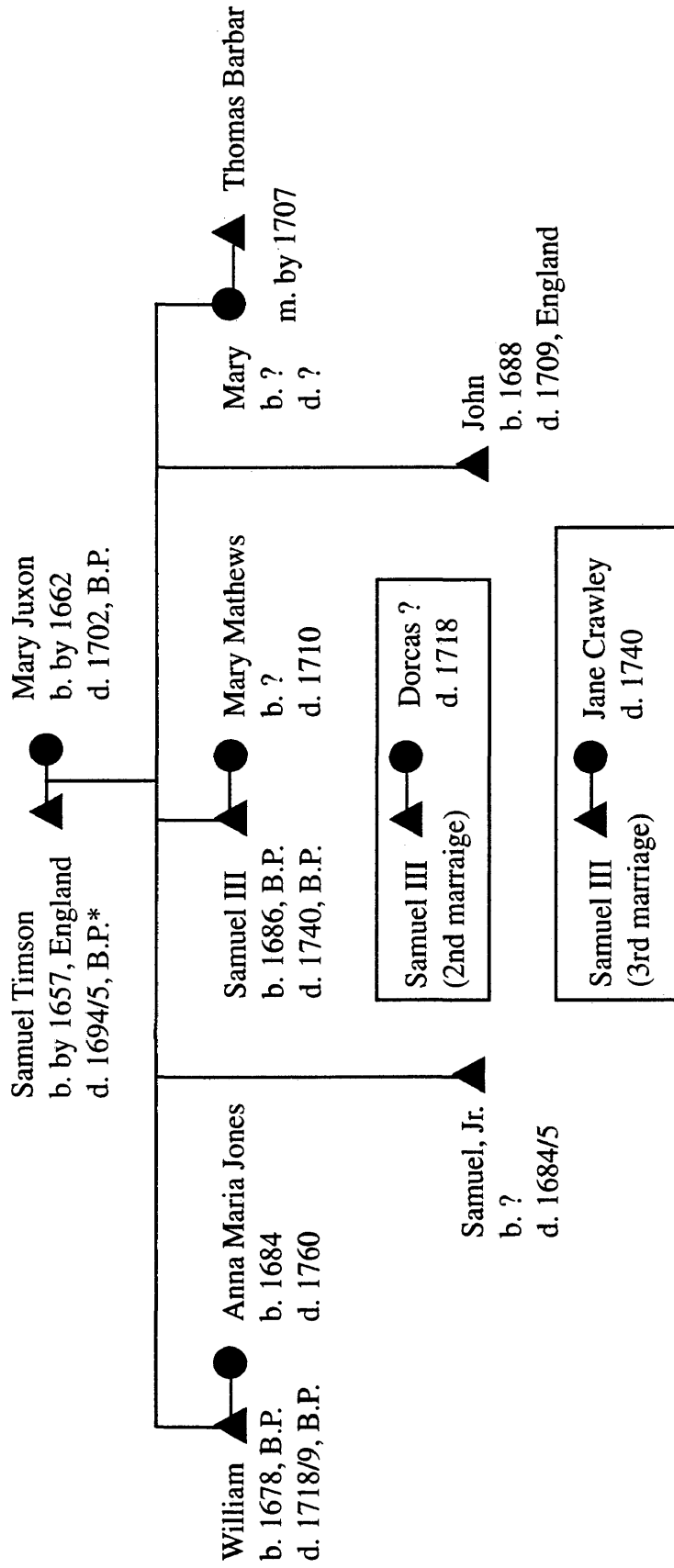

* Unless otherwise noted, "B.P." refers to Bruton Parish, York County.

FIGURE 5: WILLIAM TIMSON

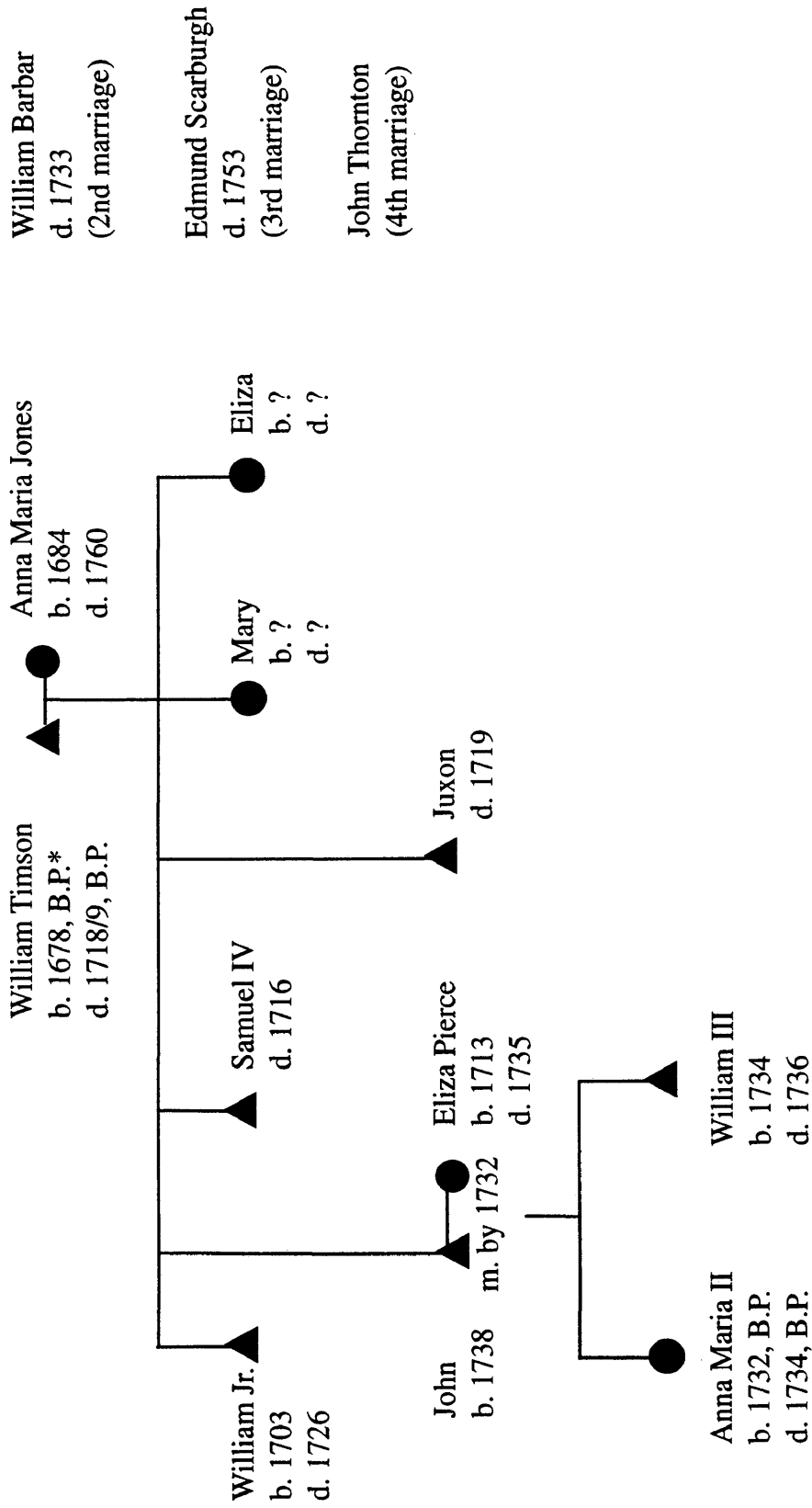

*Unless otherwise noted, "B.P." refers to Bruton Parish, York County.

FIGURE 6: SAMUEL TIMSON III

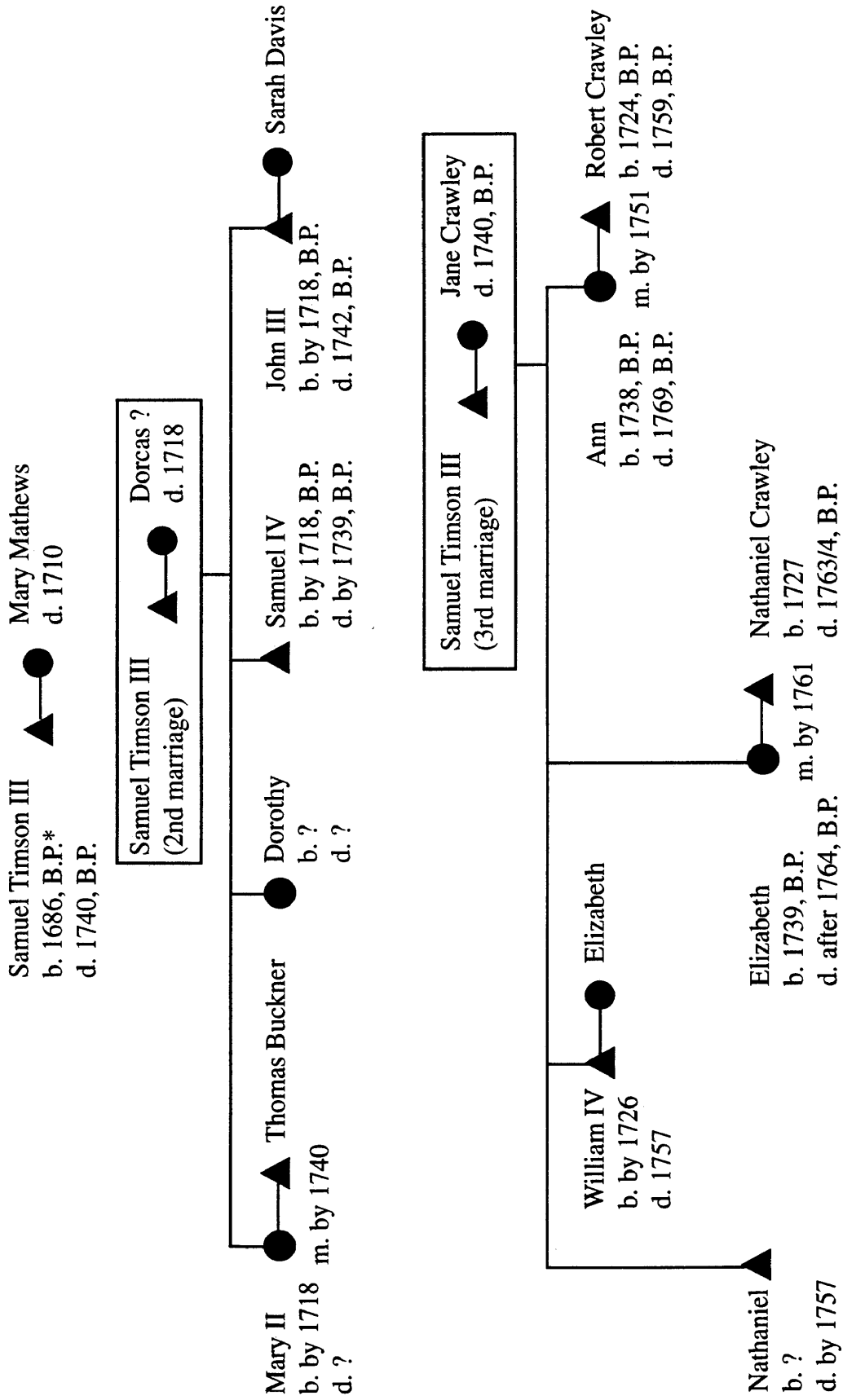

* Unless otherwise noted, "B.P." refers to Bruton Parish, York County.

CHAPTER IV

THE TIMSONS

The Timson story contains all the components of economic prosperity and security. Samuel Timson, an English merchant, arrived in Virginia with capital and political connections through which he was able to establish a large estate and amass great material wealth and a large enslaved labor force. The Timsons' inventories, probates, and wills reflect their standing in society as members of the York County elite. Samuel's first son William followed in his father's footsteps and continued to participate in similar social and political circles. Marriage is historically a key way to achieve or to maintain social status, and the Timson family tree shows the significant unions with other important families, such as the Crawleys.

In the latter part of the seventeenth century, the nature of English immigration changed. No longer were the new arrivals just the young, poor, and inexperienced. A new group of English men and women came to the colony from stable and financially sound backgrounds. They embarked on the journey to the Chesapeake with capital, prospects, and contacts in the New World. The colony had matured, and success was measured differently. Enslaved African labor appealed to a larger body of colonial businessmen and planters. The original opportunities for freemen had declined,

translating into overall economic decline among the lower classes of English immigrants.¹

Samuel Timson was one of this new generation of arrivals to the Virginia colony. Although he may not have initially known all of the intricacies of colonial customs and practices, his social standing and his skills as a merchant from England proved to be the right combination for success.

Samuel Timson: York County Gentry

Samuel Timson was born in England around 1656 and arrived in Virginia in 1677. The economic boom of the tobacco trade slowed, but new opportunities replaced the initial boom in the latter part of the seventeenth century. Timson was most likely part of a wave of non-servant immigrants who began to change the face of the colony's social and political makeup.² "This later wave of immigrants," wrote historian David Jordan, "included a number of younger sons of English gentry and merchants who bore established social and political credentials and who usually brought sufficient capital to secure large estates quite rapidly."³ Samuel Timson was an example of this phenomenon. He had paid his own passage to Virginia and as early as 1677 he was described as a merchant of York County.⁴

¹ Carr and Menard, "Immigration and Opportunity," pp. 234-235.

² David W. Jordan, "Political Stability and the Emergence of a Native Elite in Maryland," in Tate and Ammerman, eds., The Chesapeake in the Seventeenth Century, pg. 248.

³ Ibid, pg. 248. Jordan goes on to describe how this new immigrant class also contributed to social instability and economic competition. This same competition also may have caused the freedmen who could not establish such large estates and farms to move to the interior counties such as Surry County described in Kelly's "In Disprs'd Country Plantations'," pp. 183-205.

⁴ York County Deeds, Wills, and Orders (6) 55 recorded November 1677. Samuel Timson is described in an agreement to purchase enslaved Africans as being a merchant of York County.

That same year Samuel, then twenty-one, married Mary Juxon, most likely about fifteen years old. Mary was the second daughter of Margaret and John Juxon, Esq. of Sussex County, England. Mary's family was well respected in their native England. Her family included an uncle by the name of William, the Archbishop of Canterbury. Born circa 1662, she may have been born in Virginia or England, but due to her age and social standing she probably came to the colony already married to Samuel. Although there is very little documentation describing Samuel Timson's family in England, he probably held the same upper-middle class standing as his wife.

In the initial year of Timson's life in the colony he acted as a liaison for a Margarett Fellowes when she purchased four enslaved Africans that were to be placed on her property at Skiminoe Plantation in York County.⁵ Timson, as a Virginia merchant, was most likely called on as a link between English citizens who had business and property in the colony and the colonial courts. Many of these English merchants were unable to personally see to local transactions and often depended on Virginia merchants to carry out various duties. This relationship between gentry and merchant classes was one aspect that separated merchants from the colony's small and middling farmers. Colonial Virginians still relied on English goods. Each individual or family preferred to work directly with their own contacts in England which they felt were still the only means of producing reliable results.⁶

⁵ York County Deeds, Wills, and Orders (6) 55 recorded 17 November 1677. To buy Negroes Sr. wee have given commission to buy fower Negroes three men & one woman two beinge one my wifes account and two myne wee would have sett upon Skiminoe plantation. To Mr. Samuell Timpson in Queens Creeke in Yorke County at Mr. William Fellows plantation formerly Capt Chelseys these in Va.

⁶ Carole Shamma, "English-Born Elites in the Turn-of-the Century Virginia," in Tate and Ammerman, The Chesapeake in the Seventeenth Century, pp. 274-296. Shamma describes the dependence of the later gentry immigrants and how they trusted and looked to England for everything. They had no faith

In 1678 Samuel and Mary had their first son, William. There was no record or document that stated where the Timsons lived between 1677-1680, but within three years of having arrived, Timson purchased a two hundred acre tract of land four miles from Bruton Parish Church on April 19, 1680.⁷ There is some indication that Timson lived at this property or established a plantation during this three year period. As a merchant, Timson may have lived at another location until he found a parcel of property that suited his family.

A second son, Samuel II, was born in 1681. He died that same year. Not long after, in 1683, Timson provided passage for fourteen English men and women into the colony.⁸ With the land certificate Timson received through the headright system, he acquired another tract of land referred to as the "Mill Swamp" property. This land became the family home for the next twelve years. Documentation of sponsorship and accounts referred to Timson as merchant and/ or gentleman, an indication that his peers recognized his wealth and growing influence as a prominent resident of York County.

As a significant landholder, Timson became a Justice of the Peace in 1686.⁹ His third son, Samuel III (named after his deceased brother), was also born in that year. Timson often appeared in records as a gentleman associated with a number of

in what was available in Virginia and Maryland unless there was no possible way to get it from England.

⁷ York County Deeds and Bonds (3) 184-185 recorded 31 May 1717. In an arrangement by William Timson, three lots and a 200 acre tract of land four miles outside of Williamsburg was leased to James Shields, a Williamsburg tailor.

⁸ York County Deeds, Orders, and Wills (10) recorded 10 December 1683. A certificate according to Act is granted Mr. Samll Timson for the importation of Fowerteene persons Vizt.

⁹ York County Deeds, Orders, and Wills (7) 194 recorded 24 June 1686. Lord Howard his Maties Lt. Govr of Virginia & amongst other powers by his Royall Commission to me given & grant unto me full power and Authority to Constitute & appoint Justices of the peace...Mr. Samll Timson...joyntly and

Bruton Parish's most influential families such as the Pages, the Parkes, the Coles, and the Nelsons. He not only was associated with several elite members of Bruton Parish, but he was also referred to in county court documents as a man of great influence and opinion.¹⁰

For the next few years Timson did not purchase any land, perform any services for clients or friends, or appear in court. His activity indicates he was becoming a gentleman planter with an increased political and social role in Bruton Parish. The fourth son, John, was born in 1688. In 1692 Samuel purchased a Yorktown lot in York County for 180 pounds of tobacco.¹¹ Timson purchased the property in Yorktown at the same time that several other merchants and influential gentleman in York County did so also.¹² How Timson planned to use this property is unclear.

Peter Temple, a London clerk, purchased Vaulx Plantation, but defaulted on a payment of 350£ sterling. The tract of land consisted of six hundred acres along Queens Creek in York County and had several dwellings, livestock, enslaved Africans, and tobacco and corn crops. In 1694, a London merchant named George Richards died and his estate was settled. Both Richards and Temple lived in London, but as their property was located in Virginia, the debt was brought to the colonial

severally to be justices of the peace for the County of York having first taken the oaths of Allegiance & supremacy together with the oath of duely Executeing the office of Justice of peace for York County...

¹⁰Samuel Timson was often asked to stand in as a representative for landholders and influential people in England who were unable to attend to daily transactions. He often oversaw the sale of enslaved Africans (e.g. the purchasing of enslaved individuals for Mrs. Fellowes) and overseeing the purchasing of land (e. g. York County Deeds, Orders, and Wills (7) 40-41: he was appointed co-attorney by John and Sarah Juxon of London to sell 400 acres of property in 1684) and devoting a great deal of time to political offices.

¹¹ York County Deeds, Orders, and Wills (9) 188-189 recorded 25 Nov 1692. By Mr. Samll Timson 1 lott- 180 pounds of tobacco.

¹² There are several men that purchase one lot at the same time, some of the more influential names include Lewis Burwell (of what would later be known as Carter's Grove Plantation just outside of Williamsburg, Virginia), William Diggs, John Wythe, Thomas Collier, and Thomas Jefferson. It seems

court. By this time the Temple family had turned the property over to Samuel Timson, who was able to pay 421£ sterling to cover the full amount of the debt.¹³ With this transaction Timson acquired a great deal more than land. He also received specific items such as, "Houses, etc, negro slaves, cattel, horses, mares, stores, cropps of corn & tobo. goods & chattels..."¹⁴ Timson's acquisition was a well-planned action that exemplified the power of his merchant contacts on both sides of the Atlantic. In many ways Samuel Timson used the same strategies as other successful planters to amass a great deal of property and land.

Timson was still relatively new to the colonial experience and when he acquired a plantation like Vaulx, he may not have had the skills to successfully attend to all of the intricacies of plantation life. He was involved in public duties, ran a business, and maintained various properties. Timson most likely employed an overseer or plantation manager that would have seen to the daily needs of the plantation.

According to his 1694/5 will and his 1703 inventory, there were no English servants in Timson's household. Although not mentioned in either document, there were two court documents that describe two English servant women on the Timson

that this would have been the type of property that a merchant would want to have in his possession in order to build upon or pass down to his heirs.

¹³ York County Deeds, Orders, and Wills (1) 120 recorded 24 May 1695. Phillip Richards of London ... heir of George Richards late of London Merchant decd ... Whereas Peter Temple of London ... indebted to the sd. G Richards the sum of 350[pounds] ster...did for sec of payment thereof by certaine indentures dated the 1st June 1691 made btwn the sd P Temple & the sd G Richards did sell to the sd Richards all those plantations tracts or dividents of Land scituate lying & being at Queens Creek in YC Va commonly called Vaulx's Land containing by estimation 600 A ...the sd sale to be voyde the consent of the sd George Richards did lately assigne an convey to Samuell Timpson of Va Merchant and his assignes all the before mentioned plantations, livestock, negroes, etc.... the sum of 421 [pounds] of lawfull money of England...to have and hold forever. 3d Sept 1694.

¹⁴ York County Deeds and Bonds (1) 120 recorded 24 May 1695. Assignment of an Indenture of Mortgage.

property. The documents revealed that the two women were brought before York County court for allegations of giving birth to two mulatto children around the time of Timson's death in 1694 and 1695.¹⁵ This account may have been the only evidence of problems faced by Timson on his plantation. There was often very little left behind by planters like Timson that spoke of personal experiences and how individual operations were run.

Samuel Timson died in 1695 at the age of forty. In that same year his youngest child and only daughter, Mary, was born. At the time of his death, Timson owned 980 acres of land. His life was a testimonial to the new class of colonial immigrants. By the end of the seventeenth century, profound change had taken place in Virginia's political, social, and economic structure. Timson was a firmly established member of the politicians that had begun to transform the laws and policies of the entire colony.

Timson's inventory exemplified what Walsh and Carr described as a show of strength by the colonial elite. New patterns of consumption, the structures they lived in, and other various forms of colonial comfort characterized their position.¹⁶ Through his inventory, Timson seemed to have placed great importance on comforts and luxuries that were not available to all in York County. When Timson arrived in

¹⁵ York County Deeds, Orders, and Wills (10) 106-107 recorded 25 February 1694/5....Joseph Waters a free negroe for keeping company with an English woman & constantly lying with her, as per the information of Timothy Pinckithman.... Now when this was brought up in court another incident was to appear in the next court involving Mr. Timson's English woman named Elizabeth Owell. Ibid (10) 121 recorded 25 March 1695. Ordered that the sherr take Mr. Timsons servant woman named Eliz Owell into Custody...having comitted the sinn of fornication with a Negro per the information of Sarah Taylor.

¹⁶ Lois Green Carr and Lorena S. Walsh, "Changing Lifestyles and Consumer Behavior in the Colonial Chesapeake," in Ronald Hoffman, Cary Carson, and Peter J. Albert, eds., Of Consuming Interests: The Style of Life in the Eighteenth Century (Charlottesville, 1994) 62-65. Walsh and Carr describe several indications for the differences between the poor, middle class, and the elite of late seventeenth-century landowning families.

Virginia, his primary occupation was not that of a planter, but when he acquired Vaulx Plantation he secured a very prominent position in York County.

Timson's inventory provides a picture of how the house at Vaulx Plantation might have looked. The house plan seemed to have had the necessary space for Timson's large family, and was likely larger than most smaller and middle range plantation homes at the end of the seventeenth century.¹⁷ The house consisted of a hall and parlor on the first floor and contained rooms over the hall, parlor, and porch. By the way in which the inventory was recorded, there seemed to be no kitchen, although there was kitchen-related assemblage. This may indicate a detached kitchen that would have served to house enslaved Africans and to perform domestic chores. The Timson house probably accommodated a wide variety of activities. On the main floor there seemed to have been very little furniture. For example, in the parlor there were eight leather chairs, two "old" chests, and a folding table.

Timson's personal space was very comfortable. In the chamber over the parlor, most likely his bedroom, there was a bed, chairs, a clothing stool, a chest of drawers, a small trunk, and two looking glasses. His children enjoyed a certain level of comfort as well, having semi-private rooms; they would not have had to share common spaces like many of Timson's poorer contemporaries. His inventory also included such items as tables and chairs, rugs, a flower box, brass candlesticks, several napkins and tablecloths, silver spoons, and pewter, as well as earthenware dishes. The

¹⁷ Unlike the dwellings of small and middling farmers (mainly single story hall and parlor plans with a possible attached kitchen) many men of Timson's social class would have most likely had more substantial building, referred to by Rhys Isaac as the "Virginia House" See Rhys Isaac, The Transformation of Virginia, 1740-1790 (New York, 1988) 70-80. Extreme examples would have been Robert Carter's Nomini Hall made of brick and including a dining hall and ballroom space or Lewis Burwell's brick 72-by-43-foot house with outbuildings to match. Samuel Timson, I believe was comfortably situated in the middle of these two examples.

presence of such items was associated with the types of activities that occurred in the house. Such a large variety of items may have also meant that Timson was the proprietor of some type of small tavern or rooming house. Timson had the amenities to entertain a many people deal in this house. Many of the items in the inventory indicated that he was a man of wealth and social standing. Timson spent a lot of time dedicated to leisurely activities; he had books to read, horses to ride, and guests and visitors to entertain.

Timson's labor force consisted of sixteen enslaved Africans. There were four men (Frank, Sandy, "Mollato" George, and Sambo), four women (Bridgett, Pegg, Nanny, and an " old Negro woman"), seven children (Shock, Mingo, Joane, George, Tim, Peter, and Di), and one Indian servant with no name listed. The presence of an Indian servant was rather rare in the late seventeenth century. Having no other documents about this servant makes it difficult to determine how long he or she lived on the plantation. Whether this servant had a lifetime of servitude or was merely the last of Timson's indentured servants is not clear.

Timson's plantation was also engaged in animal husbandry. He owned nine sheep/lambs, forty-eight cows and calves, twenty-nine steers and heifers, and one bull. There was evidence that Vaulx was a well-equipped plantation, with several horses, carts, and wheels. Timson also owned several finer animals including a gray and black gelding.

The Timson children would have acquired a taste of the life common among Virginia's elite. Items of finery, the proper ways to display wealth to guests and visitors, and a sizable labor force of enslaved Africans would have been the daily

images of their childhood. Samuel Timson stated in his will his desires for his children to maintain their social positions. Timson stressed the importance of a proper education for his sons. He stated specifically in his will that his son John was to be “kept att the free school and colledge, and that the charge thereof be maintained by my whole estate...” Unfortunately, John died in 1709 at the age of twenty-one while he was at school in London. Samuel ensured that his children would start out with all of the proper materials to maintained the status for which he had worked so hard by giving each of his children land, enslaved Africans, and material goods.

Samuel Timson had come to the colony with a certain amount of capital and social standing. When he married Mary Juxon, he became directly connected to wealthy merchant/ planter families of England and Virginia. This allowed him to become quickly established among the Chesapeake upper class. The hard work and careful planning took on a new direction with immigrants such as Timson. He had climbed steadily up the social and political ladder through business relationships, but also with the one thing that all colonial gentry shared in common; land and the possession of enslaved Africans. His acquisition of a sizeable plantation through a business exchange proved to be beneficial, and as he learned the customs and the rules of plantation management, economic prosperity followed.

William Timson, Merchant Heir

William, the oldest of the Timson children, was born in Bruton Parish in 1678. The generous gift left by his father and the untimely death of his younger brother, John, allowed William to reach his majority with 500 acres of land, including 300

acres of his father's Vaulx plantation and 200 acres of the Mill Swamp property. As early as 1703 William Timson was referred to as "Captain" Timson in business transactions, court appearances, and personal relations.

In 1703, William, then twenty-five, was married to Anna Marie Jones, eighteen, of Bruton Parish in Williamsburg. Anna Marie was the daughter of Reverend Rowland and Ann Jones, originally of Oxfordshire, England. In Virginia, the Jones family was members of the gentry class. Rowland Jones, minister of Bruton Parish, had helped to build Bruton Parish church in 1678 and died with title to approximately 1,000 acres of land.¹⁸ It is unclear if William was the beneficiary to any of the Jones estate through his wife. There were no specific references to any of Anna Marie's property in William Timson's inventory.

The first year the couple was married they had their first son, William II. A year later, William Timson was selected Justice of the Peace on May 24, 1704, a position he occupied until 1718. In 1707, at the age of twenty-nine, Timson was elected Vestryman and Churchwarden of Bruton Parish. That Timson reached this position at such a young age was a reflection of his social, political, and economic standing among Bruton Parish's politically powerful. As the son-in-law of Reverend Rowland Jones, involvement in the church politically and socially would have been expected.

In the summer of 1709, William's younger brother John died at the age of twenty-one. John Timson had a will drawn up in 1707 while he was "sick and weak of body" and gave his share of Vaulx Plantation to his godson, William Timson II.

¹⁸ York County Deeds, Orders, and Wills recorded 24 February 1684/5. Purchase from Rowland Jones some 400 acres dated 17 Sep 1684.

William II was six years old when his uncle died, so his father maintained the property until he reached majority. The remainder of John's property was split among his siblings - William, Samuel IV, and Mary Barbar (then married to Thomas Barbar of Bruton Parish). Just a year after his brother died, in 1710, William Timson received another important political position; he became Sheriff for two years.

Records indicated that the elder Samuel Timson purchased three two-acre tracts in Bruton Parish, along with two hundred acres in York County, in 1680. These lands were to be divided among William, Samuel IV, and Mary Timson.¹⁹ Samuel IV and Mary sold their shares to William in 1716. In May of the next year, William leased the property to James Shields, a Williamsburg tailor and tavern keeper, for a one-year period in exchange for a fixed amount of Indian corn as rent.²⁰ In June of the same year William increased the lease to a seven-year term and changed the lease price to 300£ English money.²¹

The years between 1705-1718 proved to be as trying as they were productive. The Timsons continued to have children, including John II, Samuel V, Juxon, Mary, and Elizabeth, but early death claimed most of them. There were no exact birth dates for the children, but John II was the only son born during this time period who

¹⁹ York County Deeds and Bonds(3) 185-186 recorded 19 April 1680. The 200 acres were bought by Samuel Timson (deceased) from Samuel Wilden, merchant (deceased) of James City County and his wife Sarah. By his will, Samuel Timson left the land to be divided equally among his children, William, Samuel, and Mary.

²⁰ York County Deeds and Bonds(3) 185-186 recorded 15 July 1717. Grantor: Timson, Wm. (Gent.) – York Co. Grantee: Shields, James (Tailor) – Wmsbg. Date: May 31, 1717; Acres: 3 lots ('2 acre) in Wmsbg + 200 acres in York Co.; Price: 5s English money. Bounds: Lots # 46, 47, 323 on city plot – granted to Timson by trustees of Wmsbg. By lease & release. The 200 acres were bought by Saml Timson (dec'd), father of Wm., from Saml Wilden, merchant (dec'd) of James City Co. + his wife Sarah, by deed of April 19, 1680. Bounds of 200 acres: To have & to hold for one year, with the yearly rent of [] grain of Indian corn.

survived to majority. Samuel V, Juxon, Mary, and Elizabeth seemed to have died relatively early in childhood. William II died before he reached the age of sixteen and John II lived to adulthood, yet died at the young age of twenty-three.

William Timson was always referred to in court records and documents as a gentleman of York County. This was an indication of how the efforts of his father and all of the land and possessions left to him translated into his birthright as a member of the upper middle class. Not only were the land and assets held by William extensive, he also held important positions such as churchwarden, justice of the court, and sheriff. William lived on what was always referred to as the Queen's Creek property, located four miles outside of Williamsburg. His house had a number of rooms and several comforts and luxuries worthy of the wealthier colonial planters of the time.

William Timson died on February 16, 1719 at the age of forty-one. He left behind a large amount of land, property, and a solidified place for his family in the gentry class of colonial Virginia due to his political and social clout. He was well respected and revered in Bruton Parish. Visible on his gravestone located at Travis Point in York County is this inscription:

²¹ York County Deeds and Bonds(3) 186-187. Grantor: Timson, Wm. (Gent.) – York Co; Grantee: Shields, James (Tailor) – Wmsbg.; Date: June 1, 1717; Acres: 3 lots (“2 acre) in Wmsbg + 200 acres in York Co .;Price: £300 English money. Bounds: see lease, May 31, 1717.

Here Lyeth interred [] of a
J[] Resurrection the Body of
Willm Timson on of hes Majestys
Justice of the Peace in the Colony
[] of Virginia who was born
May the 3rd 1678, and Died in
Year of our lord 1718/9 A []
[] year of his Age

Such testimony suggests William's importance among not only his family, but among members of the community.

His detailed room-by-room inventory added to the picture of how his manor house may have looked. There was an upper level that contained two garrets,²² one over the parlor and the other over the hall, and chambers over the hall and the parlor. On the lower level there was a hall, parlor, kitchen, and a room above the kitchen. Within the hall there were three tables, a dozen cane chairs and one cane couch, a looking glass, two large pictures and eleven small pictures on the wall. Also in this room was a Bible, ornaments for the mantle, brass fire implements, various silver dining utensils, a silver watch, and many other expensive amenities, including an umbrella.

Privacy was considered a luxury. Timson separated his personal spaces from the public area of his home. The garret over the parlor housed most of his clothing. Among his personal items was a wide variety of clothing, suitable for different occasions. An example of some of the clothing items listed in the inventory included:

3 large chests
2 flasketts
1 new saggathey coat with a burdet waistcoat & britches
1 suit of druget clothes
a parcell of wearing clothes
3 silver hilted swords & 2 belts
5 pr. Of old hose
1 cane
3 pr. of old gloves
1 pr. Of new shoes
1 pr. worsted hose

Timson's parlor chamber was elaborately decorated with a feather bed and all of the furniture that went along with it, a chest and a looking glass. He had five leather chairs, a clothes stool, brass candlesticks, snuffers, earthenware, seven pairs of sheets, curtains, table clothes, various ornaments, and three felt hats, two guns, and a parcel of old books.

Timson's kitchen included items for preparing segmented, elaborate meals. His separate kitchen chamber allowed his family to hide items not suitable for public display, but necessary for household daily activities. Some of the items included five brass candlesticks, bread trays, several pots, pans, and other cooking implements. The inventory indicated an organized kitchen space, enough to imply that enslaved Africans attended to the specific needs of the household. There was more evidence of this in how the chamber above the kitchen may have been used. There were old beds, old tools, nails, earthenware, kitchen implements, and even a speaking trumpet (used as a hearing aid device). Items such as these indicated that although Timson owned different properties, his enslaved Africans most likely lived above their workspace.

²² A garret is a storage space located on the second floor of a house.

The speaking trumpet was more curious and may even suggest the presence of an older enslaved person who was still vital to the household.

Like his father, William owned a well-equipped plantation with livestock and horses ridden for leisure as well as racehorses. Timson's property reflected how many large plantations in the region looked. No tools appeared in his personal inventory. He owned a large labor force of nineteen enslaved Africans and his estate was valued at just over eight hundred and eighty-one pounds, which placed him among the upper echelons of planters. Men such as Timson would not have been labeled "farmer."

Timson's labor force consisted of five men (Sandy, George, Timothy, Andrew, and young George), three women (Moll, Alice, and Frank), three old women (Joane, Sambos Nanny, and Andrews Nanny), and seven children (Andrew, Halladay, Billy, Paul, Dinah, Cate, and Poll). Interestingly, there was one "servant" boy described as a mulatto to be freed, most likely when he reached the age of eighteen or twenty-one. Similar names that appeared in Samuel Timson's inventory were also present in William's inventory. There may have been established enslaved families that were left to William by his father. Names like Sambos Nanny and Andrews Nanny, point to this likelihood. The variety of ages present on the plantation (again through the use of listed values) also indicates the establishment of lasting kin relations. This is a good example of how the enslaved community was affected by the death of a master, and how division among heirs directly impacted enslaved family stability.

Anna Marie Timson fared rather well following the death of her husband. She remarried three times and acquired a great deal of wealth and prosperity. Anna Marie were likely a popular widow in her time. She was from a wealthy and prestigious

family and she most likely benefitted from her family's political and social clout. She married William Barbar (d. 1733), then Edmund Scarborough (d. 1753), and finally John Thorton in 1755, who outlived her. She left behind a detailed will and an interesting probate inventory upon her death. She alone owned approximately nineteen enslaved Africans that she ordered the court to sell. With the monies received she wanted her debts paid and a tomb for her burial purchased. Like her first husband, Anna Marie wanted a burial that would testify for generations to her importance in the community.

William's oldest son, William III, received his father's main house and part of the Queen's Creek land. The rest of the Queen's Creek land went to John II. Samuel V received the land at Mill Swamp. Just before Timson died, he added the stipulation that his youngest son was to inherit his property at Mannequin Town Plantation in Henrico County. The lease agreement between William Timson and James Shields was permanently sold to Shields after William Timson died.

William Timson lived a very comfortable life. He was one of the charter members of the native-born gentry class that benefited from slave ownership. His father began as a merchant with political and social clout. That clout ensured that William would retain the appropriate social and political status of the Timson clan. Although William's ties with England were much less pronounced than his father's ties, sending his son John to England for an education was a testimony to the continued importance of European connections.

Linking the Crawleys and the Timsons

Samuel III was born in 1685, the third son of Samuel and Mary Timson. His father had established the Timson family as members of the colonial elite. The two Timson sons were the only surviving Timson men born to Samuel and Mary, therefore their wealth was greater than other young men of similar standing. Samuel III received the remainder of Vaulx Plantation, which established Samuel III as a wealthy plantation owner.²³ Samuel III reached adulthood with land, household amenities, and a sizeable labor force of enslaved Africans. Samuel III was also very important in the story of the two families discussed in this study. With his third marriage he became the link between the Timson and Crawley clans. The two families lived on neighboring plantations, but the marriage of Samuel Timson III and Jane Crawley stood as testimony to how social and economic aspects of Chesapeake life often came together.

Samuel III had four children by his first wife, Mary. The four children were Mary, Dorothy, Samuel IV, and John IV. He and his second wife had no children. Samuel III then married a woman named Jane Crawley, who was related to Robert Crawley and his descendants. Based on the dates of her life and the fact that her children by Timson appeared on both the Crawley and Timson family trees, she most likely was part of the second generation of Crawleys to live in Virginia. Samuel III and Jane had four children: Nathaniel, William IV, Elizabeth, and Ann.

²³ York County Deeds, Orders, and Wills (10) 159 recorded 24 May 1695. In Samuel Timson's will the portion of Vaulx plantation that was left to Samuel III may have already been partially developed. The will states, " And to my sonn Sam'll the plantation whereon Robert Rickman now lives into his halfe to them & their heires forever."

Judging by the appearance of his household, Samuel did extremely well for himself. His manor house was elaborate and contained a great deal of specialized space. Based on his inventory, the floor plan was a two-story hall, parlor, and backroom with a porch and kitchen. Samuel III had an active life, with three wives and children from his various marriages. His family used the downstairs space in a variety of ways. The hall was likely for business transactions and entertaining. There were twelve chairs, two tables, and a desk. The parlor was used as a bedroom as indicated by a bed, furniture to go with it, chest of drawers, a looking glass, and a parcel of books. The back room was for storage and odd kitchen supplies. The upstairs was fully equipped with personal comforts and provided privacy. His kitchen had all of the specialized tools and equipment for elaborate dining and entertaining. There even appeared to have been some garden-related items for use just outside of the kitchen.

Samuel III was a prime example of a prominent plantation owner. His manor house reflected his lifestyle, and his amenities mirrored the importance of private and public spaces as to display their prestige.

Samuel III owned a total of twenty-two enslaved Africans. He owned two properties, only four enslaved people were listed with the second property. There were four men (Poplar, Stratford, Cambridge, and Limus), six women (Margaret, Nanny, Judith, Phillis, Fanny, Sarah, and Bess), and eleven children (Stephen, Sue, Philip, Will, Pegg, Edith, Harry, Betty, Mary, and Tom). With the number of enslaved men, women, and children to work his plantation, Samuel III had reached the highest

possible level of colonial social circles for his time. The ownership of human property remained the central characteristic of wealth enjoyed by the elite.

When Samuel Timson III married Jane Crawley the descendants of both families were united by the success of immigrant forefathers and mothers who searched for a better life in Virginia. That a man of Samuel III's social class would chose a descendent of Robert Crawley to take as his wife underscores the fact that the Crawleys had become members of the gentry in York County.

CHAPTER V

CONCLUSION

During the mid- to late seventeenth century, the colonial Chesapeake developed a distinct social structure that encompassed enslaved Africans, free people of color, newly freed indentured servants, small to middling farmers, merchants, and native-born gentry. Two men, Robert Crawley and Samuel Timson, understood that social mobility was based on agricultural success. As an indentured servant, Crawley learned first-hand how to grow food, practice a trade, and be frugal enough to survive the initial hard times faced by a small planter. In contrast, merchant Timson learned very little about the methods of agricultural production through hard work. Instead, he used his skills as a businessman and purchased the essentials needed to make the transition from merchant to planter.

The public documents provide the only sources of personal accounts left by many of Virginia's earliest settlers. Probates and inventories can be used to recreate the way colonial society was organized, the value placed on material goods, and the importance of inheritance. These documents also become a valuable tool for the interpretation of the symbolic and active meanings of material culture. When

critically analyzed, these documents stand as testimonials to the daily lives of individuals often absent from early colonial history.

The story of the Crawleys is a testament to the possibility of achieving success in the New World. Through the hard work and determination of Robert Crawley, the family was able to move fluidly through the social and political circles unattainable in England. Social systems were not static in the Chesapeake; the Crawley family had to acquire land, capital, enslaved labor, and material wealth. Each child was able to increase their resources, ensuring their place among the native-born gentry in York County.

The Timson story was different. The family began their colonial adventure with the means to quickly establish land, wealth, and enslaved labor. The Timsons relied heavily on their social status and political allies. Maintaining “proper” social circles through marriage, commercial transactions, and political office was a major aspect of the family’s strategy. The marriage of a Timson to a Crawley speaks to the fact that both families were “important” in the colonial community. The Timsons would be able to continue their economic power and financial security through various unions of this sort.

Wealth, prosperity, and social mobility were directly linked to the ability to adapt to a new social ordering of colonial society. As slavery became more profitable and the African population increased, white officials saw a need for mechanisms to allow even the poorest of English settlers to maintain their position in the colonial hierarchy.¹ Clearly, the overall distribution of wealth favored the men who owned

¹ Morgan, American Slavery, American Freedom, pp. 338-341.

large plantations, but with the ever-increasing demand for tobacco in the world market, slavery was the key to ensuring growth and economic prosperity for anyone who owned lifetime laborers.²

The probate records of both men revealed that they actively participated in the displacement of English servant labor. The majority of successful small and middling farmers saw this as the only tactic that could guarantee positive results. The ownership of enslaved Africans was clearly an important social and economic strategy for ensuring status mobility. The enslaved population meant much more than just labor, they were an essential source of economic and social prosperity for the white men and women who owned them. Soon all whites viewed the ownership of enslaved Africans as directly connected to wealth, status, and political and social success.

This study concentrated on the lives of two white men and their descendants. In many ways these narratives reflected the changes that were taking place in the Chesapeake at this time. Through the analysis of material culture and public documents, a finer interpretation of how chattel slavery affected the early years of colonial Virginia is possible. These documents leave behind a fragmented and incomplete story of women, children, and enslaved Africans who were a central component of the history of colonial Chesapeake society.

By focusing on Robert Crawley, Samuel Timson, and their descendants, I had hoped to tell the narratives of two men and their enslaved Africans, wives, and children. Due to the fragmentary nature of public documents, only the beginnings of their stories can be told. Yet, in emphasizing the role of material culture and the

² Ibid, pg. 345.

ownership of enslaved Africans in prestige and social mobility, the accounts of the historically neglected have become a part of the colonial story.

APPENDIX A

INVENTORY OF ROBERT CRAWLEY I

DOW (11) p. 19-20

An Inventory of the Estate of Robert Crawley decd taken & Appraized this 3d day of March 1697/8.
pris

18 Hides of lether att 6s 6d	05 17 00
11 Kippe skins of lether att 2s 6d	01 07 06
25 Raw Hides att 4s 6d	05 12 00
1 Barke Stone	02 00 00
2 fleshing knives two hooks	00 03 06
9 coves att 35s	15 15 00
3 two year olds att 15s	02 05 00
5 yearlings att 7s 6d	01 17 06
23 old sheep 10 lambs	11 00 00
2 old horses	05 00 00
1 Iron tooth Harrow 1 ox Chaine	00 10 00
1 pitch fork	00 01 00
2 old horse harnis & Cart Saddle	00 12 00
5 Raw hides	01 00 00
4 Iron potts, 4 pot hooks	01 03 00
3 pair of pot racks	00 06 00
2 Spitts one [old And] Iron	00 05 00
2 frying pans	00 03 00
5 Iron wedges, 1 Iron pestall	00 10 00
1 Hand Saw & meal Sifter	00 02 06
1 Spice mortar and pestall	00 02 06
1 Negro woman and Child three yeares old	30 00 00
1 Negro man and their beds	27 00 00
3 Sifting trayes, 22 milk traies	00 11 00
1 old powder tubb	00 05 00
7_ taned hides	02 10 00
1 Hide upper lether	00 09 00
1 old Copper kettle 8 gallons train oyle	01 12 00
4 Sider Casks and a pcell old Casks & one Chest	01 10 00
3 Narrow axes & 2 hamers, 5 weedings howes	00 12 00
1 Ads, 1 trowell, 1 hatchett	00 05 00
1 Stocklock, 1 chissell, 1 gimblett	00 02 00
4 fether beds, 2 Curtaines and vallans & Covering	18 00 00
<hr/>	
Mr. Crawley's wearing Cloaths	04 00 00
1 Chest, 1 small box	00 10 00

A parcell of shoo makers tooles	00 10 00
2 Cards buttons, 3 pair womans hoase	00 [07] 00
[unclear – torn]	[06]
1 Small table, 2 Lining Wheels	01 00 00
6 old Chaires, 1 Chest	00 12 00
1 trussle, 2 Curryers knives & stoole	00 10 00
1 old Saddle and bridle	00 06 00
2 old guns, 1 carbine	01 05 00
1 Cheespress, 1 old flock bed & Covering	01 00 00
1 old brass kettle and Chest	01 05 00
2 Sickles, 1 hook	00 02 00
1 long table and 1 round table	00 10 00
1 dressing box 3 cubborts	04 00 00
1 wainscot Couth and Warming pan	00 12 00
2 Chests, 1 small trunck	00 10 00
1 lookeing glass, 1 lanthorne	00 04 00
17 pewter dishes, 15 plates	03 00 00
1 Silver tumbler	00 10 00
3 old basins, 4 old dishes 2 plates	00 10 00
2 porringers, 1 mustard pott	00 02 00
2 Candlesticks	00 04 00
2 tanners barks	00 03 00
2 Chamber potts	00 03 00
1 gallon flagon, 1 gallon pott	00 05 00
1 grid Iron 2 paire fire tongs	00 05 00
1 pair small Stilyards 1 pair great Stilyards	01 00 00
1 flower pott, 1 iron Candlestick	00 01 00
Mr. Crawley's library	00 05 00
1 branding Iron, a slate	00 02 00
4 Rush Chaires	00 04 00

162 11 06

Robert Bee
Ambrose Cobbs
James Whaley

York County March the 24th 1697
presented in Court & ordered to Record which is Accordingly pformed.

Test Willm Sedgwick Cl. Cur.

Dow (11) p. 107

An Inventory of the Remaining part of the Estate of Robert Crawley dec'd To Witt—

To a Cross Cutt Saw	00 05 00
To a pcell of Cart Wheel Irons	06 00 00
To a parcell of old Iron	00 08 00
To 3 old slaves att	01 06 00
To a parcell of table lining	00 08 00
To nine [clipt] shillings	00 09 00
To 2 pair Sheep Shears	00 01 00
To a baskett	00 01 00
To 2 pair Cards att	00 01 06
To 3 pair mans falls	00 01 00
To 1 pair womans shoes 2 pr Childrens	00 06 00
To 1 Smothing Iron	00 01 00
To 1 old Adds, 1 howell	00 02 00
To one [?] Capp att	00 01 00
To [Awgr.], 4 barking Irons	00 04 00
To 3 sides lether att	00 15 00
To 13 Ells Virginia Lining	00 15 00
To 5 Ells dowlis	00 12 00
To 1 doz pewter Spoons	00 02 00
To one [torn]	00 01 06
To one [torn] skellit att	00 01 00
To 34 [torn]	00 15 00
To Az[torn]	00 10 00

12 09 06

James Whaley
Robert Bee
Ambrose Cobbs

Bills

A list of bills due to the estate of Robert Crawley, deced,

To a bill of Ann Sebright	To a bill of Emanel C [oe]st
To Mr. Weldon's bill money	To William Harrison's bill
To a bill of John [G]ulson	To a bill of John Tillett
To a bill of William White	To a bill of Phill. Ryan
To a bill of David Johnson	To a bill of Thomas Ellison

To a note of Coma[n]'s
To William Debell's bill
To a bill of Giles Bowers

To Tim: Pinckethman's bill
To a bill of Robert West

Nathaniel Crawley
Robert Crawley

York County Court June 14 1698

The above inventory was then produced & sworn in ct by the above named Nathaniel
& Robert Crawley and is recorded.

Test: Wm Sedgwick Cl Cur.

APPENDIX B

WILL OF NATHANIEL CRAWLEY

Dow (15) 116-7

20 May 1717

In the Name of God Amen I Nathaniel Crawley of York County being sick & weak of body but sound & perfect memory, praise be given to God, do Make & ordain this my last Will & Testamt. Revoking & hereby disanulling all former Wills whatsoever by me made. First of all I bequeath my Soul to Almighty God that gave it in hopes of pardon for my Sins through the merits of my blessed Lord & saviour Christ Jesus & Estate has [sic] it hath pleased God to bless me with after my Debts & funeral Charges paid, I do bestow in manner & form following Imprimis I give unto my loving Son Jno. Crawley my Manner plantation & all my land in James City County from the upper Corner Oak Close by a Spring side & Close by the Swamp to him and his heirs forever.

Item I give unto my Son Robt. Crawley all the Remainder of my Lands from the aforesd hickory stump running up the Road till it comes to Capt. Wm. Timson's line, from thence along an Antient marked line down to Cabbin run, so up the sd Rum to the forementioned white oak by a straight line to be made to the aforesd hickory stump to him & his heirs forever.

All the rest of my Estate which God Almighty has been pleased to bless me with both Negroes & all my other goods & chattels to be equally divided among my loving & espoused wife Elliner Crawley & my aforesd Sons Jno Crawley & Robert Crawley. Each one to have share alike.

Lastly I do ordain & appoint my aforesd loving wife Elliner Crawley Execrs. Of this my last Will & Testament as Witness my hand & Seel this 19th day of Xber 1711.

Natt. Crawley

Test Jno D. Davis
Ambr. Cobbs
Jno Steward

APPENDIX B (2)

INVENTORY OF NATHANIEL CRAWLEY I

York Co. Orders, Wills
 Vol. 15, 1716-1720
 pp. 165-166

In Obedience to an order of York County Court baring date the 15th July 1717 We the
 Subscribers have mett & Inventoryed & appraised the Estate of Mr Nathl. Crawley
 deced. As follows Viz:

2 Nego Men Will & Robin & their beads at £30. 10s Each	61 00 00
1 Nego Man cald Tom & his bead at	35 10 00
1 Nego Woman cald Cate & her bead at	20 10 00
1 Young Do cald Hanah at	35 00 00
1 English Servant named Jno Barar at	00 12 00
In the Chamber---	
1 feather bed wth. Bolster 2 pillow & Cases. 1 Rugg 1 Pr blankets 2 pr. Sheets, Curtains & Vallens & bedstead	10 00 00
In the Garrett over the Hall---	
1 Do. & furniture	08 00 00
In the Kitchin Chamber---	
1 featherbed & bolster 1 Rugg, 1 Pr blankets, 2 Pr Sheets 1 bedsted & Corde	07 00 00
1 Servants bead & bedstead	01 00 00
1 Small Trussill bead, 1 Rugg, 4 pr Cotton Blankets, 1 Pr Virga. Cotton Sheets	02 00 00
2 large [?] falling Tables	02 10 00
2 Do. Less at	02 10 00
1 Small Do. At	00 15 00
1 doz: Rushy Leathr. Chairs at 9s p	05 08 00
4 Small Old Chairs at 4/ Each	00 16 00
1 old Trunk, 1 Small box	00 07 06
1 large Sielskin Trunk at	01 15 00
2 Diaper Table Cloaths & 14 Knapkins	03 12 00
4 old Table Cloaths, 5 Towels, 3 pillow Cases	00 12 00
1 Warming pan, 1 Pr brass Doggs, 1 Pr. fire tongs, 1 pr. Bellows belonging to the Chamber	01 05 00
18 Sticks Mohair, 6 doz: brest buttons, 3_ doz Coat buttons 3 doz: Horne Do. 4_ Yds. Drugget	

at 3s. P yd	01 05 03
1 Saddle & holsters, 1 P Pistolls, 1 Sword	03 10 00
1 Men's Saddle & bridle at 2£. 1 Gun 25s	02 10 00
1 bald faced horse at	04 00 00
2 Old Cart horses, 1 Cart & Wheels, 1 old Sett of horse harness	06 15 00
2 looking glasses	01 00 00
2 pr. of Money Scales, 1 Pr Sm Stillyerds	00 15 00

--

231 06 03

6 Sickles, 2 beef rope	00 05 06
6 m. Eight penny Nails. 2400 Tens, 900 Twenty penny	02 08 00
6 pewtr basons, 6 dishes, 15 plates a Pcell old peweter, 1 doz: alcamy Spoons	02 15 00
1 Small Still	00 08 00
a Pcell Old Tin	00 03 00
1 large Iron pott & hooks, 2 small Do, 2 pott rack 1 frying & dripping pan 3 Spitts 1 fork	03 00 03
2 P large Dogg Irons, P largest at 25/	02 05 00
1 large brass kettle, 1 Small Do, 2 brass Scimers, 1 Ladel 1 mortar & pestill, 3 brass Candlesticks, 1 Pr Snuffers 1 Small bell Mettle Skillit	03 11 06
1 Small washing Tubb, 2 old pails, 1 half bushell	00 06 00
1 Cross Cutt Saw & file, 1 Sythe, 4 Pr fire tongs, 1 Iron pestills, 1 Spade	00 19 00
70 ib. Wooll 2 old baggs	02 03 09
1 Spinning Wheel, 1 Pr. Cards	00 05 00
1 Tanners knife, 1 Pr Cross Garnish, 2 Iron hoops	00 09 00
1 Small Sett of Irons for Carte Wheels	00 10 00
1 lb. Yarn & Pcell Virga. Cotton	00 06 00
2 old Chests, 2 Meal barrils, a Pcell Old Casks & Tubs 5 baskets, 3 Syder Cask, 2 beer Rundlets	02 00 00
4 Hydes Tan'd Leather	02 05 00
2 old bread Trays, 3 Meal Sives, 2 yds hair Cloth	00 08 00
1 Grindstone, a Pcell old Iron & old Lumber	00 15 00

258 00 01

11 Cows, 5 five Year old Steers, 3 three Year Old Do.
7 Two Year Olds, 4 Yearlings, 5 Calves, 2 bulls
The sd. Cattle is to be Equally divided by Agreemt. of the Legatees without praising

Elinor Crawley

Ambr: Cobbs
Jno. Steward
Math: Pierce
Wm Jones

At a court held for York County 16th Septemr. 1717 Elinor Crawley Execrxor of
Nathl. Crawley deced. Presented the within Inventory & Appraisment of the sd Estate
& it is Admitted to Record

Test Phi: Lightfoot Cl Cu

APPENDIX C

WILL OF JOHN CRAWLEY

WI (20) 107-8

20 June 1748

In the name of God --- I John Crawley of York County in Bruton Parish being disordered I body but blessed be God in perfect Sence and Memory do make this my last Will & Testament in manner & form following.

Item I give and bequeath to my son Nathaniel Crawley the Land whereon I now live joining to Williamsburgh to him and the Male Heirs of his Body lawfully begotten forever and for want of such Male Heirs my desire is that my Son John Crawley to have the said Plantation to him and the Male Heirs of him Body lawfully begotten forever and for want of such Male Heirs then I do give the said Plantation to my son Robert Crawley to him and the Male Heirs of his Body lawfully begotten forever but if the Seat of Government should be moved from Williamsburgh then either of my three sons Nathaniel Crawley John Crawley or Robert Crawley may dispose of the said Plantation as either of them shall think proper but if the Seat of Government is established here then my will and desire is that the said Plantation to remain firmly in my family as long as any is to be found.

Item I give and bequeath to my son John Crawley that Plantation where I formerly lived to him and his Heirs forever but if he dies without Lawful Issue then the said Land to go to my Son Robert Crawley to him and his heirs lawful forever.

Item I give and bequeath to my Son Robert Crawley that Plantation which was formerly William Forbors and likewise I do give him another Plantation which my Uncle left me to him and his Heirs forever.

Item I give and bequeath to my Son John Crawley one Negro Girl about the Age of ten years old and all the rest of my Negros to be equally divided between my three Sons when they shall come to Age except two Negros which I shall hereafter give to my Wife.

Item I give and bequeath to my Daughter Elizabeth Crawley one hundred pounds Current Money and also one back room in one of my Dwelling Houses and one bed til she marries.

Item I give and bequeath to my Daughter Hannah Crawley one hundred pounds current money.

Item I give and bequeath to my Daughter Mary Crawley one hundred Pounds Current money.

Item I give and bequeath my Daughter Eleanor Segrove Crawley one hundred pounds current money.

Item I give to my loving Wife two Negros and my Dwelling House furnished during her natural life and after her death the said Negros to be divided between my three Sons and all the rest of my Personal Estate of what kind soever after my Wifes death may be equally divided between all my Children.

I do constitute and appoint my Son Nathaniel Crawley and my Son in Law Thos Cowles Exrs. of this my last Will and Testament Signed and Sealed this twelfth day of April Seventeen hundred forty eight.

John Crawley

Test

Thos. Cobbs

John Coulthard

Mary Cobbs

Rebecca (x) Coulthard

APPENDIX C (2)

INVENTORY OF JOHN CRAWLEY

York County Wills and Inventories 20, 1745-1759, pp. 110-111

A Bill of Appraisalment made on the Estate of John Crawley decd.

28 Head of Cattle at 35/ per head	£ 49 00 00
2 Calves a 8/ 1 Harrow 10/ 1 Fluke Hoe 5/	01 11 00
2 Cross Cut Saws 15/ 2 Mares & 1 Colt £6	06 15 00
19 Geese 19/ 4 Ducks 2/6 3 Spades 6/ 4 Axes 8/	01 15 06
5 Ox Chains 4 Yokes with Irons 30/ 1 hand Iron 5/	01 15 00
1 Grindstone 2/1d. 6 Hoes 1 Grubbing Do. 14/	
1 frying Pan & old pot 3/ 1 old brass kettle 2/	01 01 01
2 Hides 3/ a parcel of old Iron a 1d. per lb. 10/	00 13 00
1 Brass Cock 1/3 2 old Pistols 2/ 4 Wedges 7/6	00 10 09
1 Iron Pestle 5/ 1 Hammer & a rope 4/ 5 Cider Casks 18/	
236 Bottles at 26/ per Grace	03 09 07
1 Negro Named James £40 James Junr. £40	80 00 00
1 Do. Peter £30 Sarah £30 Will £8	68 00 00
1 Gun Bayonet and Cartouch Box 30/ 1 Do. old Gun &	
Bayonet 10/ 1 pr. of Dogs 10/	02 10 00
1 pr. Money Scales 1 Candle box 1 pr. Sheep Shears	00 05 00
1 Pail 6d. 9 Leather Chairs 27/ 2 Tables 20/	02 08 03
1 Corner Cupboard 7/6 1 Bed a pr. of Sheets, Rug, Pillows	
Bedstead Cord and Hide £4	04 07 06
1 Do. a pr. of Sheets a Rug Bolster and Pillow Bedstead	
Cord and Towell 3/9d. a Bed Bolster a pair of	
Sheets a Rug &c. £2	02 03 09
A parcel of old Window Glass 8/ 2 old hogsheads 6/	00 14 00
15 Sheep £3.15/ 3 Reaping hooks 2/3 1 Horse called	
Mattle £5 1 Sorrel Do. £5 1 Do. £4	17 17 03
1 Bay Mare £5 1 Riding Chair & Harness for 2 Horses £12	
3 old Barrels & a piece of Rope 3/ 1 Ox Cart 30/	18 13 00
Negro Sam £45 Do Judith £45 Cate £30	120 00 00
A Negro by Name Harry £10 Judith Junr. £30	40 00 00
Abigal £6 Negro Paul £40	46 00 00
6 Cows 4 Yearlings and a Calf	11 00 00
1 Womans Saddle & Bridle 15/ 1 Brass Kettle 8/ 35 Pewter	
Plates 24/ 12 Do. Dishes 40/ old Pewter 30/	05 17 00
1 Wash Bason 2/6 a small Pestle & Morter 3/	00 05 06
1 Bell Metal Kettle 3/ 1 Box Iron & Heaters 3/	00 06 00
1 pr. hand Irons 20/ 3 Iron Pots and Racks 25/	02 05 00
3 Pails 3/ 1 Spit 1 pr. Tongs, and a frying Pan 5/	00 08 00
1 Large Iron Pot 12/ 1 Dripping pan 7/6	00 19 06

1 Grid Iron & Lumber 10/ 1 old Table 2/6 1 old Iron Pot 1/6	00 14 00
A Parcel of old Casks 8/ 1 Jarr 7/ a parcel of Leather 12/	01 07 00
A Parcel of Tallow 20/ 4 Brass Cocks 5/ 5 Jugs 14/	01 19 00
4 Butter Pots 6/ 1 Bay Colt 15/ a pr. of Stilyards 8/	01 09 00
A Bed, Rug, Bolster, Pillows, Bedstead Cord, & Hide a pair of sheets	05 00 00
Do. without a Bedstead £3 1 old Bed 2 Pillows 1 pr. of Sheets 1 Rug 35/ 1 Warming Pan and 2 Chamber pots 5/	05 00 00
1 Violin 10/ 1 pair Cotton Cards 4/ 1 Buckskin 5/	00 19 00
1 old Bed pr. Sheets bolster and Rug 35/ 1 Do. a pr. of Sheets a Bolster 1 Pillow Bedstead £4.10/	06 05 00
1 Do. £4.10/ 1 Do. £3.10/ 1 Do. £3.10/	11 10 00
1 Bed &c 20/ 5 Blankets 1 Rugg 1 Osnabg. Tick 30/	02 10 00
2 Chamber pots 1/3 a parcel of wearing apparel £6	06 01 03
1 doz: Panes of Glass 7/6 1 Saddle Cover 10. 1 Bolster Case 2/	00 19 06
Spun Cotton 7/6 2 Swords 7/6 2 lb thread & some Flax 3/	00 18 00
1 Desk 30/ 1 pr. Money Scales 7/6 a parcel of Lumber 5/	02 02 06
2 doz: Silver Waistcoat Buttons 10/ 1 Looking Glass 20/	01 10 00
1 Oval Table 15/ 1 Do. 15/ 9 Leather Chairs 54/	04 00 00
2 Rush 3/ a Parcel of Books 30/	01 13 00
A Parcel of Earthen Ware & Glasses 6/ 1 Cloaths brush & Grater 15d.	00 07 03
1 pr. Iron Dogs 2/6 a parcel of Spun Yarn wt. 27 lb. at 1/6 per lb.	02 00 06
A Bed a Bolster a pr. of Sheets Rug Bedstead Cord and Hide	03 00 00
1 Square Table 3/ 1 Do. Walnut 2/6 2 pr. Window Curtains 2/6	00 08 00
1 Bed Bolster pr. of Sheets Rug Bedstead	05 00 00
1 Bed £5 1 Chest & Candle Box 4/6 a pr. Window Curtains 2/	05 06 06
1 Tea kettle & a parcel of Candlesticks 14/ 40 Yards of Irish Linnen 40/ 1 Saddle 2/6	02 16 06
A parcel of Wool & some Yarn 4/ a pr. of Wool Cards 2/ 11 Turkeys 13/9 18 Dunghill Fowls 6/	01 05 09
A parcel of Knives and forks and Spoons 5/ 7 Towels, 3 Table Cloths 15/ 1 Hoe 1 Ax 4/6	01 04 06
1 Rake with Iron teeth 2/ 1 Drawing Knife and Real 1/3d	00 03 03
1 Bed &c. £3.10/ 1 Spinning Wheel 4/6 _	03 14 06_

£ 572 14 09

In Obedience to an Order of the Worshipful Court of York County we have Appraised the Estate of John Crawley decd. accordingly.

Henry Wetherburne
James Shields
Matt: Shields

Returned to York County Court the 18th of July 1748 and Ordered to be Recorded.
Examd.

Teste

Thos. Everard Cl: Cur:

APPENDIX C (3)

SETTLEMENT OF JOHN CRAWLEY'S ESTATE

York County Wills and Inventories 20, 1745-1759
p. 145

The Estate of John Crawley decd.

Dr.		p. Contra	Cr.
To Widow Crawleys thirds Vizt.			
Sam	£45.00.00	By Sam a Negro fellow	45 00 00
Great Judy	40.00.00	By Great Judy s Negro Wench	40 00 00
Little Judy	30.00.00	By Little Judy a Girl	30 00 00
Harry	15.00.00	By Harry a Boy	15 00 00
To Nathl. Crawleys part Vizt.			
Peter	38.00.00	By Peter a Boy	38 00 00
Paul	40.00.00	By Paul a Fellow	40 00 00
To John Crawleys part Vizt.			
Little Jemmy	40.00.00	By little Jemmy a Boy	40 00 00
Kate	35.00.00	By Kate a Girl	35 00 00
To Robert Crawleys part Vizt.			
Great Jemmy	45.00.00	By Great Jemmy a Fellow	45 00 00
Will	15.00.00	By Will a Fellow	15 00 00
Abigail	10.00.00	By Abigail a Girl	10 00 00
To Negro Sarah left Jno. Crawley by Will	25.00.00	By a Negro paid John Crawley as per Will	25 00 00
	----- 378.00.00		----- 378 00 00

Elizabeth Crawley Widow to pay her
three sons Nathl. John & Robert £4.00.00 to be equally divided among them.

Nathl. Crawley pay Robert his Brother 3.13.4

John Crawley pay Robert his Brother 0.13.4

Pursuant to an Order of York Court bearing Date the 16th January 1748/9 We the Subscribers have laid off and assigned unto Elizabeth Crawley her dower in Slaves of her late husband John Crawley decd. And have made a Division of the Residue of the said Slaves among the Children of the said Decedent they paying to each other as above as Witness our hands this 24th day of January 1748/9.

Thos. Cobbs
Henry Wetherbourn
Mat. Pierce

Returned to York County Court the 20th day of March 1748 and Ordered to be Recorded.
Examd.

Teste
Thos. Everard Cl. Cur.

APPENDIX D

INVENTORY OF SAMUEL TIMSON

York County Records, DOW 12, pp. 212-213
Inventory of Samuel Timson

An Inventory of the Estate of Mr Samuel Timson Deceased March the 16th 1703/4

6 Sheep & 3 Lambs	
31 Cowes	
17 Calves	
3 Steares five Yeares Old	
3 Steares four Yeares Old	
4 Steares three Yeares old	
3 Heiffers four Yeares old	
7 two Yeares old	
9 One Year old	
One Bull	02 00 00
One old Horse, 1 Harness, 1 Cart, 1 Wheele	06 00 00
One Mare & Colt	03 00 00
One Horse 3 Yeares Old att	02 00 00
One Mare 4 Yeares old	02 10 00
One small Horse 4 Yeares old	02 00 00
One Gray Gelding	05 10 00
One Black Gelding	04 10 00
One very old Horse	01 15 00

In the Hall

12 Leather Chares, one small table	03 17 00
One Bed & Furniture	12 00 00
One pr of Doggs brass heads tongs & fire shovell	01 05 00

In the Palar

Eight old Chaires 2 old Chests	01 00 00
One folding Table	01 05 00
One pair Iron Doggs 1 pair of Tongues	01 00 00

In the Chamber over the Palar

One Bed & furniture	09 00 00
6 Leather Chaires one Close stoole	02 06 00
One Chest of Drawers 1 Small Trunk	01 10 00
One large Lookingglass one small	01 08 00

In the Porch Chamber

One old feather Bed & furniture 05 00 00

In the Hall Chamber

One Trussell, 1 Rugg, 1 Blanket 1 Sheet 1 Bed 01 10 00
 One old Looking Glass 00 02 06

In the Garrett over the Hall

One feather bed one flack Bed & furniture 04 05 00
 3 old Chest, 1 old Spice box 01 00 00

In the Garrett over the Palar

One feather bed & furniture 04 10 00
 two old Chests 00 13 00

 81 16 06

118# of Old brass att 12d 05 18 00
 57# of Old Pewter at 6d 01 08 06
 23# of Midling Pewter at 12d 01 03 00
 3 Pewter Basons 5 Porringers 2 Cha: potts 1 qt: pott
 1 funnell 1 flower box 01 00 00
 2 Brass Candlesticks 1 Warming Pan 00 15 00
 1 Tin pastey Pan 1 Kittell 2 Skilletts 00 10 00
 4 Iron Potts 3 pr Potthooks 02 00 00
 2 pott racks, 2 Spitts 1 old Drip: pan 01 00 00
 4 Candlesticks 2 Smoothing Irons 1 Old Mortar & 1 Grid Iron 00 07 06
 1 pair of Iron Doggs 1 pr of Tongs 1 Old Still 02 00 00
 [] Trench [] 00 05 00
 Eight Course Table Clothes 11 Towells 10 Napkins 01 17 00
 11 Diaper Napkins 1 Table Cloth 01 00 00
 13 Pillowbeares 00 16 06
 A parcell of Books & Lumber in the Closet 02 10 00
 9 Sheets 02 05 00
 4 Pillows 2 Ruggs, 3 Blanketts, 1 Bed Tiken 04 05 00
 1 Old Flock Bed & Eight Sickles 01 00 00
 7 Old Cyder Cask 1 Old Case & Bottles 01 00 00
 2 Old Chest 4 Doz: bottles one Peck 01 00 00
 2 pair of Old Styliards 00 12 00
 One old Silver Tankard one Cupp 08 00 00

11 Silver Spoons att 11	06 01 00
One parcell of Earthen Ware	00 12 00
One old Bottle	00 15 00
8 Hogg 2 Yeares old	
8 Hoggs 1_ Yeares Old	
8 Hoggs one Year old	
8 Shotes _ Year Old	
One Negro Frank, 1 Wo: Bridgett	42 00 00
One Negro Man Sandy, 1 Wo: Pegg	50 00 00
Molatto George & Sambo	60 00 00
One Molatto boy Shock	12 10 00
One Negro boy Mingo	30 00 00
One Negro Girl Jone	15 00 00
One Negroe Boy George	12 10 00
One Negroe boy Tim	10 00 00
One Negroe boy Peter	30 00 00
One Negroe Girle Di	30 00 00
One Negroe Nanny	30 00 00
One old Negroe Wo: one Indian	20 00 00

--

390 00 06

In Obedience to an Order of Court wee the Subscribers have Invitoried & Aprized the Estate of Mr. Samuel Timson Deced.

Wm Timson Junr

Edward Wigg
Wm. Penkethman
Bar. Howells
Ambrose Cobbs

March the 24th 1703/4
Then presented in Court by Capt. Wm Timson
On his Oath & According to Order is Recorded

P Willm Sedgwick ClCur

APPENDIX E

INVENTORY OF WILLIAM TIMSON

York County Records, Orders, Wills, 15, 1716-1720, pp. 512-515

November 11, 1719

In Obedience to an Order of Court Baring Date Sept 21st 1719 wee the Subscribers have mett Invented & appraised the Estate of Capt Wm Timson decd Ass followeth—

(Viz) In the Garrett Over the Parler Chamber

3 Large Chests 2 Flasketts	£	01 07 06
1 New Sagathay Caott wth a Burdett Wescoate & Breeches		04 10 00
1 Sute of Drugett Cloaths		05 00 00
a parcell of Old Wearing Cloaths		04 00 00
3 Silver Hilted Sword & 2 Belts		06 00 00
5 pr of Old Hose 1 Caine 3 pr Old Gloves		00 19 00
1 pr of New Shoes 1 pr Worsted hose		00 13 00
---		-----
		22 09 06

In the Garrett Over the Hall Chamber

7 Chests & 1 Small Box		02 00 00
1 New Rusher Leather Saddle 2 bridles 4 girts		02 15 00
1 Old Screane 1 wickard Chaire 1 Old Spining Wheele		01 00 00
1 feather bed & bouster 2 pillows 1 Rugg 1 blankett		
1 Sute of Curtains & Vallins		06 10 00
2 Sides of upper Leather		00 08 00
1 Trooping Saddle pistols & houlsters 1 half Cheek bridle		04 10 00
1 parcell of Spanish brown & Spanish wht. paint		00 15 00
10 old Sickles		00 04 00
----		-----
		40 12 06
		[40.11.06]

In the Chamber Over the Hall

1 feather Bed & all furniture to itt	11 00 00
1 Chest of Draws 1 Dressing box 1 Looking Glass	04 00 00
6 Caine Chairs 1 Low Leather Do: 2 Brushess	01 18 00
1 pr of small hand Irons 1 pr fire tongues	00 07 06
1 Old falling Table 1 Old Looking Glass	00 12 06
2 Small Tables Carpitts 2 Setts of Window Cirtaines & Vallins 1 Chimney Cloath	00 12 00
a parcell of Earthen Ware upon the Mantle tree	00 03 00
1 Diaper table Cloath 25 Knapkins Do.	02 02 06
1 Old Dowlis table Cloath 1 Doz of Holland Knapkins	01 08 00
1 pr holland Sheets	03 00 00
2 Old Table Cloaths 2 Doz Huckaback Knapkins	02 02 06
1 pr Corse Holland Sheets	01 07 00
2 wht Ozbriggs Table Cloaths 6 Knapkins	00 10 00
a parcell of Old Table Lying	00 04 00
1 Doz of pillow Cases 6 Towells	00 17 00
1 Old Cabinet 2 Chests 2 boxes 3 Old Wood Chaires	00 15 00
1 feather bed 1 Rugg 1 blankett 1 pr Sheets 1 bedsted & Card	05 10 00

In the Camber Over ye Parler

1 feather bed & all furniture to it 1 Chest of Draws 1 Large Looking Glass	09 00 00
1 Little baskett 1 pincoshing 2 Comb boxes	01 15 00
5 Leather Chairs 1 Closestool 2 Tables	02 05 00
1 pr Brass Candlesticks & Snuffers some Earthen Ware	00 07 06
7 pr Sheetts	05 00 00
1 pr Window Cloaths 2 Table Carpitts 1 small Case of Bottles 4 boxes 1 old Desk	00 07 06
a parcell of small Trifling things	00 05 00
a parcell of Paticaries Goods	00 12 00
1 Large Gar & three Juggs	00 06 00
9 _ Ells Sheeting Holland	01 12 03
16 _ Ells broad Garlix	02 09 06
7 yds of Kersey	01 01 00
8 Doz of Coat Buttons 3 felt Hatts	00 13 00

103 15 00
[103.14.03]

11 Sticks Mohaire 1 Grose Ticken buttons	00 07 08
1 fine Caster Hatt 16 lb Castle Soape	01 12 00
a parcell of Old Books 1 Old Large Bible	02 00 00
16 yds of Ticking 1 Perewigg	01 19 00

1 New sute of boys Drugett Cloaths 1 pr hose	01 17 06
2 Guns	03 00 00

In the Hall

3 Old Tables 1 Screwtore & Old Carpetts	04 10 00
1 Doz of Caine Chairs 1 Caine Couch	05 05 00
1 Looking Glass 2 Large pictures 11 small Do	05 00 00
a parcell of Cupps & Ornaments for the Mantlepeice	00 07 06
1 Large Silver Tankard 1 Do Can 10 Do Spoons	18 10 00
a parcell of Old Silver 13 Old Silver Spoons	06 12 00
1 pr Iron Doggs 1 pr Brass fire-tongs & Shovle	01 10 00
3 knives & forks 1 horn hand Do	00 01 08
a parcell of Old Shewmakers tools 1 hand Vise with some other old tools	01 00 00
4 howboys 1 Gaging Rod	00 07 00
1 Decanter 1 Sugar Box 1 umbarillow	00 09 00

In ye Parler Chamber

1 feather bed & all furniture to it	08 10 00
1 Trunill bed Do	02 10 00
1 Chest of Draws 1 Dressing Box 1 Looking Glass	02 05 00
3 Old Tables 7 Old Leather Chaires	01 17 06
1 press & a parcell of Earthen Ware	01 05 00
1 Doz Case knives & forks 3 Do Old Knives 6 forks	00 08 03
2 Sutes of Window Curtains 1 Lanthorne one Spy Glass	00 06 00
a parcell of Trifling things some Old Books	00 06 00
2 pr Old Stilyards 1 pr Shott Moulds	00 17 06
3 Smoothing Irons 1 box Iron Do	00 05 06
1 pr Iron Doggs 1 pr fire tongs	00 17 06

In the Ketching

10 puter Basons Sorted	01 18 06
2 Doz puter plates & 38 lb old puter	03 03 00
1 bed pan & pasty pan	00 06 00
2 Doz Old puter plates	01 00 00
30 _ lb puter Little Worn 1 putter Callinder	01 16 00
a parcell Old puter 2 puter Candle Moulds	01 05 00
2 Doz _ tin pattery pans a parcell of Old Tin 1 quart pot	00 12 06
1 Brass Kettle 2 Older Do 1 Warming pan	06 02 06
5 brass Candlesticks 1 pr snuffers 2 Ladles 1 Skimer	00 12 06
4 bellmettle Skilletts 1 Do Morter & Pestle	01 15 06
2 Spits 2 frying pans 1 Driping pan	00 14 00
5 pr Sheep Shears 2 Iron pestles 1 pr fire tongs 1 flesh fork	00 08 00

3 Large stone Butter pots	1 Small Do	3 Earthen Do	00	17	06
2 bread trays	1 powdering tub	a parcell of Old Barrells			
		1 box	00	12	06
2 pr Old Skales & Wts			00	07	06
2 Sack Baggs	1 Do Ozembriggs		00	08	00

In the Ketching Chamber

2 Old Beds	1 old Rugg	25 lb new feathers	00	02	00
2 Old Saddles & Bridles			01	05	00
	a parcell of old Coopers tools	1 hand saw	01	10	00
1 Sithe	2 Wedges		00	09	06
6m 8d Nails	5 Broad hows		02	00	00
2 Chests & a prcell of Wool			02	15	00
	a parcell of 10d nails about 10m		03	10	00
10 Syder Caskes			01	15	00
	about 5 bush of salt		00	15	00
2 Syder Caske	1 Do bear Caske	1 Old pipe	00	10	00
	a parcell of Earthen Ware		00	03	00
1 Speaking Trumpet	1 branding Iron		00	04	00

--

226 07 10
[226.06.04]

1 Cart & Wheelles with old harniss			05	00	00
2 meale Sifters	2 Do Wire Sifters		00	06	00
87 bottles	2 Stone Judgs		00	18	00
1 bedstead & a parcell of Old Lumber			00	15	00

Cattle

14 Large Steares			28	00	00
4 Small Do			05	00	00
11 Small Steares & heafears			06	17	06
4 Bulls			04	00	00
25 Cows			34	07	06
11 Yearlings			04	19	00
44 head of Sheep			12	02	00
1 Old Cart horse			02	00	00
2 Old Mares Do			04	00	00
2 young Mares Do			02	00	00
1 Spade Mare Do			02	15	00
1 Small Riding horse			03	00	00
1 Do Large paceing horse			06	00	00
26 head of Hoggs			09	02	00
24 Shote Do			03	00	00

--		360 09 10
		[360.08.04]
Negroes		
1 Negro man Named Sandey		20 00 00
1 Do Mallatto named George		30 00 00
1 Negro man named Andrew		37 10 00
1 Mullatto man Called young George		37 10 00
1 Do Mullatto Named Timothy		37 10 00
1 Servt boy to be free a Mollatto		20 00 00
1 Negro boy Named Andrew		30 00 00
1 Do Named Halladay		27 10 00
1 Do Named Billy		18 00 00
1 Old Negro Woman Named Joane		05 00 00
1 Do Called Samboes Nanney		25 00 00
1 Do Called Andrews Nanny		35 00 00
1 Do Named Moll		37 10 00
1 Do Young Wench Named Alce		32 10 00
1 Do Named Frank		32 10 00
1 Do Girl Named Dinah		27 10 00
1 Do Named Cate		27 10 00
1 Mullatto Girl named Poll		18 00 00
1 Negro boy Named Paul		22 10 00
--		881 09 10
		£ [881.08.04]

Annamaria Timson

At a Court held for York County Novr 16 1719
 This Invry was presented in Court by the
 Execrs & Admitted to Record --

Robt Cobbs Junr
 Matth Peirce
 Wm Jackson

Test Phi Lightfoot ClCur

APPENDIX F

WILL OF SAMUEL TIMSON III*

WI (18) 603-4

23 October 1739

To son John Timson: the land that was given by his grandfather in Blisland parish in New Kent to him and his heirs and all my horse arms and accountriments.

1 guinea for a ring.

The use of two Negroes named Cambridge and Sarah so long as Mrs. Anna Maria Scarburgh shall live and then returned to the estate and then to be equally divided among his four children.

To son William Timson: tract of land whereon I now live.

1 guinea for a ring.

To Nathaniel Timson: land Samuel Timson III bought from George Wigg in Blisland parish of New Kent County.

1 guinea for a ring.

One Negro named Fill.

To daughter Elizabeth Timson: Two Negroes named Patt and Betty.

1 guinea for a ring.

To daughter Anne Timson: One Negro woman named Moll.

Item I will and bequeath to my [sic] Mary Buckner a guinea to buy her a ring.

Wife to have children's estates during widowhood or til they come of age.

Remainder of estate equally divided between wife and children vizt. William, Nathaniel, Elizabeth, Ann

*this is an absract – not a full transcription.

APPENDIX F (2)

INVENTORY OF SAMUEL TIMSON III

York County Wills & Inventories 18, 1732-40
pp. 679-680

An Inventory of the appraisal of Saml. Timsons Estate late of York County
decd.

To 2 Steers one Bull £3.10	To 12 Cows	
	2 Steers £14	17 10 00
To 6 Two Year old £3.12	To Yearlings £2.2	05 14 00
To 1 horse one Mare & Colt £4		
	To 14 hogs £3.15	07 15 00
To 15 Do. £3.3	To 23 Sheep £5.15	08 18 00
To 2 old horses one Mare		02 10 00
To Quinn Stones one Grind Stone		00 10 00
To 1 Saddle & housing 26/	5 old Cask 5/	01 11 00
To 3 hydes & Skins 14/	To 6 old hhds 12/	01 06 00
To 1 Cart and harness 35/	To 1 Corn barrl.	
	& 2 Trays 3/	01 18 00

In the Porch Chamber

To 1 Looking glass and Table		01 07 00
To 1 Trunk 4/	To 1 Bed & fruniture £8	08 04 00
To 1 Damask Table Cloath and 12 Napkins		02 11 00
To 5 Napkins & 3 Towels 7/		
	To 3 pr. holland Sheets £4.10	04 17 00
To 2 Table Cloths & 4 pr. Sheets		02 08 00
To 4 pillow Cases a Counter pin & 2 Napkins		00 05 00
To 2 Chairs		00 14 00

In the Room over the Hall

To 1 Bed and furniture £5	To 3 boxes & 1 Speaking Trumpet	05 08 00
To a parcel of peas at 2/ p. bushell		

In the Hall

To 1 Looking Glass 10/	1 Desk 30/	12 Chairs £4.10	06 10 00
To 2 Tables £3	pr. of Dogg Irons	Tongs & Shovell 40/	05 00 00

In the Porch

To 30 lb. of old Iron 2/6 3 pr. hinges 2 brandg. Irons 7/	00 11 06
To a pacl of old Tools 10/ 1 Crosscut Saw	
1 old Table 12/6	01 02 06
To 1 pr. small stillards	00 05 00

In the Parlour

To a parcel of books £3.5 To 1 Bed & furniture £3	06 05 00
To 1 warming pan 2 Chairs and Lumber	00 18 00
To 1 Bed & furniture £9 To 1 Do. 40/	11 00 00
To 1 Chest of Drawers and Looking Glass	06 00 00
To 6 Chairs 2 Trunks 1 Chest & Lumber	01 19 00

In the Back Room

To a pcel of Lumber £2.5 pr. Togs and Irons Flat Irons Ct. 20/	03 05 00
To 1 Case of bottles & Lumber 15/ doz. Silver Spoons Do. £9.18	10 13 00
To 6 small Do. Tongs and Strainer c. s	01 10 00
To 1 large Silver Tankard	10 00 00
To 2 pint Silver Cans £4 2 Silver Salvers 2 Salts £6.12	10 12 00
To 1 China punch bowl and 6 plates	02 05 00

Carry'd up	151 02 00
------------	-----------

Brot up	151 02 00
---------	-----------

To a parcel of China & Tea board	03 02 06
To 1 Tea pot Decanter Ct.	00 10 00
To 4 pr. Scales & weights one burning glass & 2 Raizors	01 16 00
To 5 jugs & 5 butter pots	01 03 00
To 5 hydes & 2 Skins in Tan 3 Sides of Sole Leather 1 Side & pr. of upper	02 01 00

In the Kitchen

To 6 Iron pots pot hooks and rack	02 02 00
To 1 brass Kettle and Skillet	04 00 00
To 1 Gallon pot and pr. Garden Shears 8/ 19 lb. pewter 14/10	01 02 10
To 1 frying pan a Spitt an Iron pestle And Tea Kettle	00 07 00
To 1 _ doz. Pewter plates 22/6 52 lb. pewter at 15d.	

p. lb. £3.5	04 07 06
To 1 pr. old Dogg Irons qt. 22 lb. 1/10	
a pcel of Lumber 7/	00 08 10
To 1 Spice Mortar 3/ a parcel of old Cask 32/	01 15 00
To a parcel of Iron wedges 16/ a Silver watch £5	
1 good Gun 20/	06 16 00
To a parcel of Troopers Arms Ct.	09 00 00
The Crop of Corn at 5/ p. barrl. And the Crop of	
Tobo. At 15/ p. Ct.	

Slaves to wit Poplar £35 Stratford £30 Nanny £20	85 00 00
To Margaret £20 Stephen a boy £27 Sue a Girl £20	73 00 00
To Phillip a boy £17 Will a boy £15 Judith a wom. £30	62 00 00
To Edith a Girl £10 Harry a boy £10 Fanny a wench £26	46 00 00
To Latter Betty £15 Patt a Girl £15 Cambridge a Man £35	65 00 00
To Sarah a wench £25 5 old hoes 2 Axes a froe &	
Hone 13/6	25 13 06

At the Quarter in New Kent

To 17 hoggs & 18 piggs £6 30 head of Cattle £25.1	31 01 00
To 1 Mare & Colt £2.10 1 Bules hyde 4/	02 14 00
To 1 pot 4 hoes 2 Axes and some Cask	00 06 00

Slaves there

To Limus £30 Bess £20 Mary £15 Tom £25	90 00 00
The Corn at 5/ p. Barrl and the Tobo. At 15/ p. Ct.	

705 16 02

Purst. to an order of York County Court we the
Subscribers being duely quallify'd have appraised the
Above sd. Estate as foregoing is Specify'd witness our
Hands this 13th day of Decr. 1740.

Jane Timson

Ralph Graves
James Shields
James Barbar

At a Court held for York County Febry the 16th 1740/1
This Inventory & Appraisement of the Estate of Saml. Timson
dec'd. Was this day ret'd. To Court and order'd to be recorded.

Test.
Matt Hubard Cl. Cur.

BIBLIOGRAPHY

- Beaudry, Mary. *Documentary Archaeology in the New World*. Boston: Cambridge University Press, 1988.
- Beaudry, Mary. "Words for things: linguistic analysis of probate inventories." In *Documentary Archaeology of the New World*, edited by Mary Beaudry. Boston: Cambridge University Press, 1988.
- Blassingame, John. *The Slave Community: Plantation Life in the Antebellum South*. New York: Oxford Press, 1972.
- Brown, Marley R. III. "The Behavioral Context of Probate Inventories: An Example from Plymouth Colony." In *Documentary Archaeology in the New World*, edited by Mary Beaudry. Boston: Cambridge University Press, 1988.
- Bushman, Richard L. *The Refinement of America: Persons, Houses, Cities*. New York: Alfred A. Knopf, 1992.
- Carr, Lois Green. "Emigration and the Standards of Living: The Seventeenth-Century Chesapeake." *Journal of Economic History* 52 (1992): 271-292.
- Carr, Lois G. and Lorena S. Walsh. "Changing Lifestyles and Consumer Behavior in the Colonial Chesapeake." In *Of Consuming Interests: The Style of Life in the Eighteenth Century*, edited by Cary Carson, Ronald Hoffman, and Peter J. Albert. Charlottesville: University of Virginia Press, 1994.
- Carr, Lois G. and Lorena S. Walsh. "Inventories and the Analysis of Wealth Consumption Patterns in St. Mary's County, Maryland, 1656-1777." *Historical Methods* 13, no. 2 (1980): 81-104.
- Carr, Lois G. and Lorena S. Walsh. "The Standard of Living in the Colonial Chesapeake." *The William & Mary Quarterly* 3, no. 45 (1988): 135-159.
- Carr, Lois Green; Menard, Russell R.; Walsh, Lorena S., ed. *Robert Cole's World: Agriculture and Society in Early Maryland*. Chapel Hill: University of North Carolina Press, 1991.

Carson, Cary, Norman Barka, William Kelso, Gary Wheeler Stone, and Dell Upton. "Impermanent Architecture in the Southern American Colonies." *Winterthur Portfolio* 16 (1981): 135-196.

Carson, Cary, Ronald Hoffman, and Peter J. Albert, ed. *Of Consuming Interests: The Style of Life in the Eighteenth Century*. Charlottesville: University Press of Virginia, 1994.

Dunn, Richard S. "Servants and Slaves: The Recruitment and Employment of Labor." In *Colonial British America: Essays in the New History of the Early Modern Era*, edited by Jack P. and J. R. Pole Greene. Baltimore: Johns Hopkins University Press, 1984.

Elkins, Stanley. *Slavery: The Problem in American Institutional and Intellectual Life*. Chicago: The University of Chicago Press, 1959.

Epperson, Terrence. "Constructing Difference: The Social and Spatial Order of the Chesapeake Plantation." In *"I, Too, Am America": Archaeological Studies of African-American Life*, edited by Theresa A. Singleton. Charlottesville: University Press of Virginia, 1999.

Gallman, Robert and John Joseph Wallis. *American Economic Growth and Standards of Living Before the Civil War*. Chicago: University of Chicago Press, 1992.

Genovese, Eugene D. *Roll, Jordan, Roll: The World the Slaves Made*. New York: Vintage Books, 1972.

Glassie, Henry. "Meaningful Things and Appropriate Myths: The Artifact's Place in American Studies." In *Material Life in America, 1600-1860*, edited by Robert Blair St. George. Boston: Northeastern University Press, 1988.

Greene, Jack P. *Pursuits of Happiness: The Social Development of Early Modern British Colonies and the Formation of American Culture*. Chapel Hill: University of North Carolina Press, 1988.

Henretta, James A. "Wealth and Social Structure." In *Colonial British America: Essays in the New History of the Early Modern Era*, edited by Jack P. and J. R. Pole Greene. Baltimore: John's Hopkins University Press, 1984.

Herskovits, Melville. *The Myth of the Negro Past*. New York: Harper & Brothers, 1941.

Horn, James. *Adapting to a New World: English Society in the Seventeenth-Century Chesapeake*. Chapel Hill: University of North Carolina Press, 1994.

Horn, James. "Servant Emigration to the Chesapeake in the Seventeenth Century." In *The Chesapeake in the Seventeenth Century: Essays on Anglo-American Society*,

edited by Thad Tate and David Ammerman, 51-95. New York: W. W. Norton & Company, 1979.

Isaac, Rhys. *The Transformation of Virginia, 1740-1790*. New York: W. W. Norton & Company, 1988.

Kelly, Kevin. "In dispers'd Country Plantations': Settlement Patterns in Seventeenth-Century Surry County, Virginia." In *The Chesapeake in the Seventeenth Century: Essays on Anglo American Society*, edited by Thad Tate and David Ammerman, 183-205. New York: W. W. Norton & Company, 1979.

Kulikoff, Allan. *Tobacco and Slaves: The Development of Southern Cultures in the Chesapeake, 1680-1800*. Chapel Hill: The University of North Carolina Press, 1986.

Main, Gloria. "Inequality in Early America: Evidence from Probate Records of Massachusetts and Maryland." *Journal of Interdisciplinary History* 7, no. 4 (1977): 559-581.

Main, Gloria. "Personal Wealth in Colonial America: Explorations of Probate Records from Maryland and Massachusetts, 1650-1720.", Columbia University, 1972.

Main, Gloria. "Probate records as a source for early American history." *William & Mary Quarterly* 32 (1972): 89-99.

McCracken, David G. *Culture and consumption: new approaches to the symbolic character of consumer goods and activities*. Bloomington: Indiana University Press, 1988.

Morgan, Edmund. *American Slavery, American Freedom: The Ordeal of Colonial Virginia*. New York: W. W. Norton, 1975.

Myrdal, Gunnar. *An American Dilemma: The Negro Problem and Modern Democracy*. New York: Harper & Brothers, 1944.

Novick, Peter. *That Noble Dream: The "Objectivity Question" and the American Historical Profession*. Cambridge: Cambridge University Press, 1988.

Phillips, Ulrich B. *American Negro Slavery*. Gloucester: P. Smith, 1959 (c1918).

Prown, David Jules. "Mind in Matter: An Introduction to Material Culture Theory and Method." In *Material Life in America, 1600-1860*, edited by Robert B. St. George. Boston: Northeastern University, 1988.

Prown, David. "Mind in Matter: An Introduction to Material Culture Theory and Method." In *Material Life in America, 1600-1860*, edited by Robert Blair St. George. Boston: Northeastern University Press, 1988.

Rutman, Darrett B. and Anita Rutman. *A Place in Time: Middlesex County, Virginia, 1650-1750*. New York: W. W. Norton & Company, 1984.

Shackel, Paul. *Personal Discipline and Material Culture: An Archaeology of Annapolis, Maryland, 1695-1870*. Knoxville: The University of Tennessee Press, 1993.

Shackel, Paul. "Probate Inventories and Material Culture: An Archaeology of Annapolis, Maryland, 1695-1870." In *Text Aided Archaeology*, edited by Barbara J. Little, 205-216. Boca Raton: CRC Press, 1992.

Smith, D. S. "Underegistration and bias in probate records: and analysis of data from eighteenth-century Hingham, Massachusetts." *William & Mary Quarterly* 3s, no. 32 (1975): 100-112.

Sobel, Mechal. *The World They Made Together: Black and White Values in Eighteenth-Century Virginia*. Princeton: Princeton University Press, 1987.

St. George, Robert Blair, ed. *Material Life in America, 1600-1860*. Boston: Northeastern University Press, 1988.

Stampf, Kenneth. *The Peculiar Institution: Slavery in the Antebellum South*. New York: Vintage Books, 1956.

Tate, Thad W. *The Negro in Eighteenth-Century Williamsburg*. Williamsburg: The Colonial Williamsburg Foundation, 1965.

Tate, Thad W. and David L. Ammerman, ed. *The Chesapeake in the Seventeenth Century: Essays on Anglo American Society*. New York: W. W. Norton & Company, 1979.

Walsh, Lorena. *From Calabar to Carter's Grove: The History of a Virginia Slave Community*. Charlottesville: University of Virginia Press, 1997.

Walsh, Lorena S. "Community Networks in the Early Chesapeake." In *Colonial Chesapeake Society*, edited by Philip Morgan Lois Greene Carr, and Jean Russo. Chapel Hill: University of North Carolina Press, 1988.

Walsh, Lorena S. "Questions and Sources for Exploring the Standard of Living." *William & Mary Quarterly* 3, no. 45 (1988): 116-123.

Walsh, Lorena S. "Urban Amenities and Rural Sufficiency: Living Standards and Consumer Behavior in the Colonial Chesapeake, 1643-1777." *Journal of Economic History* 43 (1983): 109-117.

Wells, Camille. "New Light on the Sunnyside: Architectural and Documentary Testament of an Early Virginia House." *Bulletin of the Northumberland County Historical Society* 32 (1995): 3-26.

VITA

Whitney Lutricia Battle

Born in New York City, New York, December 2, 1971. Graduated from Harry S. Truman High School in the Bronx, June 1989, B. A., Virginia State University, in Petersburg, Virginia, 1994. Accepted to the Historical Archaeology apprenticeship program with Colonial Williamsburg's Department of Archaeological Research. An M. A. candidate, The College of William & Mary, 1994-2000. Research concentrated on seventeenth- and eighteenth-century African American history and culture. Involved in archaeological and research projects associated with Colonial Williamsburg's African American archaeology program from 1994-1996.