

Manual for Handling and Shedding Blue Crabs (Callinectes sapidus)

by Michael J. Oesterling

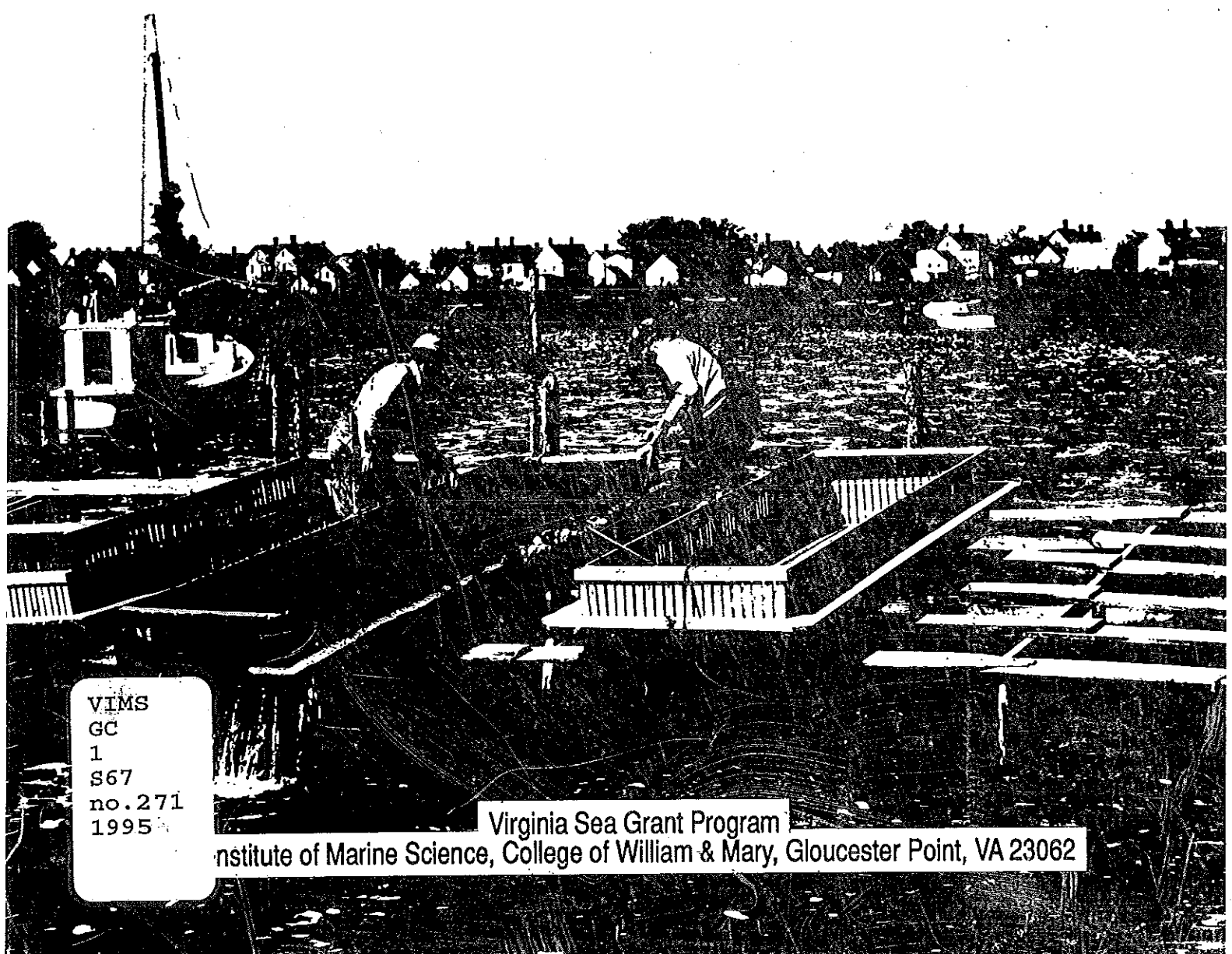

VIMS
GC
1
S67
no. 271
1995

Virginia Sea Grant Program
Institute of Marine Science, College of William & Mary, Gloucester Point, VA 23062

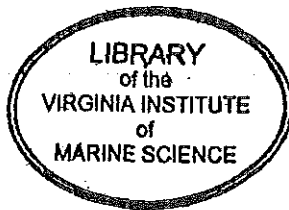

Manual for Handling and Shedding Blue Crabs (*Callinectes sapidus*)

by
Michael J. Oesterling
Marine Advisory Services
Virginia Institute of Marine Science
College of William & Mary
Gloucester Point, Virginia 23062

Special Report in Applied Marine Science and Ocean Engineering No. 271

1ST PRINTING SPRING 1984

FIRST REVISION 1988
SECOND REVISION 1995

Copies of this publication may be ordered for \$6.00 each
from the Sea Grant Communications Office,
Virginia Institute of Marine Science
Gloucester Point, Virginia 23062

Acknowledgements

In any successful production, there are players working behind the scenes who deserve special recognition for their effort.

Two people that unknowingly have assisted over the past 10 years in the development of not only this manual, but the career of the author, are Willard Van Engel of the Virginia Institute of Marine Science (VIMS) and Mike Paparella of the University of Maryland, Crisfield Laboratory. I would like to give special thanks to these two grand gentlemen of "blue crabology" who have willingly shared their extensive knowledge of the blue crab and soft-shell crab production.

Mike Castagna of VIMS Eastern Shore Laboratory offered encouragement and provided excellent advice in the material content of this manual, as well as critically reviewing the manuscript.

Thanks are also due to the staff of the Sea Grant Advisory Services at VIMS. Cheryl Teagle for typing draft portions of the manuscript; Dick Cook for final editing, artwork, photography and layout, and for putting up with my harassment, and finally, Dr. Bill DuPaul for funding and continual producing. Thanks!

And finally, but certainly not least, "thanks" is due to members of the Virginia soft crab industry. George Spence, Louis Whittaker, Roger Rawson and others have openly shared information they've gathered through years of personal experience. In some cases, industry members served as guinea pigs for field experiments. In the final analysis, industry has made much of this manual possible.

This work is a result of research sponsored by NOAA office of Sea Grant, U.S. Department of Commerce, under Federal Grant Number NA90AA-D-SG045 to the Virginia Graduate Marine Science Consortium and the Virginia Sea Grant College Program. The U.S. Government is authorized to produce and distribute reprints for governmental purposes, notwithstanding any copyright that may appear hereon.

Table of Contents

	Page
ACKNOWLEDGMENTS	i
LIST OF FIGURES	iii
PREFACE	v
INTRODUCTION	1
PEELER IDENTIFICATION AND HARVEST	3
PEELER CARE	17
FACILITY DESIGN AND CONSTRUCTION	19
The Float Operation	19
The Shore-based Facility	21
Tanks and Supports	22
Pump	26
Plumbing and Flow-through Considerations	28
Closed System	38
FACILITY OPERATIONS	59
MARKETING AND PACKAGING	66
SHEDDING ROCK CRABS	79
APPENDIX I: Sea Grant Marine Advisory Service	84
APPENDIX II: Additional Reading	86
APPENDIX III: Common Terminology of the Soft Crab Industry	88
APPENDIX IV: Determining Amount of Water in a Shedding System	91

List of Figures

	Page
Figure 1. Top view of blue crab	5
Figure 2. White line sign	6
Figure 3. Pink line sign	6
Figure 4. Red line sign	7
Figure 5. Apron of juvenile female	7
Figure 6. Comparison of abdomen shapes	8
Figure 7. A "buster" crab	9
Figure 8. Typical peeler pound net	12
Figure 9. Deep water peeler pound net	13
Figure 10. Jimmy potting	13
Figure 11. Typical crab scape	16
Figure 12. In-water crab float	18
Figure 13. Wooden shedding tank	23
Figure 14. Concrete shedding tanks	25
Figure 15. Fiberglass shedding tanks	25
Figure 16. Two-box screened water intake	30
Figure 17. Overhead water introduction	30
Figure 18. Countercurrent water input	32
Figure 19. T-aspirator	32
Figure 20. Flow-through shedding system	33
Figure 21. Overflow pipes	35
Figure 22. Standpipe drains	37
Figure 23. Nitrogen cycle	40
Figure 24. Typical conditioning response	43
Figure 25. Cross-section of biological filter	46

List of Figures (continued)

	Page
Figure 26. Corrugated fiberglass roofing material	47
Figure 27. Protein skimmer	49
Figure 28. Diagram of a protein skimmer	50
Figure 29. Cross-section of protein skimmer	51
Figure 30. Orifice venturi	54
Figure 31. Mechanical filter	55
Figure 32. Schematic of closed system	55
Figure 33. Waxed cardboard shipping box	69
Figure 34. Packed live soft crabs	70
Figure 35. Removing gills of soft crabs	71
Figure 36. Removing apron of soft crabs	71
Figure 37. Removing eyes and mouth parts	72
Figure 38. Wrapping cleaned soft crabs	72
Figure 39. Wrapped soft crab	73
Figure 40. Individual wrapped soft crabs	73
Figure 41. Rock crab versus blue crab	80

Preface

This manual is intended to present a practical approach to constructing and operating a Chesapeake Bay crab shedding facility. Included are portions of an earlier VIMS publication by Paul A. Haefner, Jr. and David Garten (1974), "Methods of handling and shedding blue crabs, (*Callinectes sapidus*)," as well as a compilation of other scientific and industry experiences.

Techniques described may not apply to all situations; in many cases general recommendations are made. Additionally, descriptions of various facility designs refer mainly to those in use in Chesapeake Bay; other areas of the country may use varying, but similar designs.

Although the information in this manual will be very helpful in establishing a soft crab shedding operation, the prudent person will seek out additional assistance. In all soft crab producing states there are Sea Grant Marine Advisory Programs (Appendix 1) or other organizations willing to provide personalized services. These people should be searched out and contacted for guidance in entering the soft crab industry. Suggestions for additional reading are provided in Appendix 2.

The use of trade names in this publication is solely for the purpose of providing specific information. It is not an endorsement of the products named and does not signify that they are approved to the exclusion of others.

Introduction

Soft crabs were being eaten long before the English settlers arrived in Chesapeake Bay. Initially soft crabs were caught in a haphazard manner. However, in the mid-1800's attempts to mass produce soft-shell blue crabs began near Crisfield, Maryland.

The past few years have witnessed a resurgence of interest in the production of soft-shell crabs. Soft-shell blue crabs are not a separate species of crab, but are blue crabs (*Callinectes sapidus*) that have shed (molted) their hard outer shells in preparation for growth. The relative ease with which crabs can be shed and the high market value for soft crabs have been instrumental in the renewal of soft crab production.

"Controlled" shedding of crabs was first conducted in wire enclosures staked-out in tidal areas. These crab "pounds" were filled with hard-shelled crabs which were fed and watched closely for the appearance of soft crabs. This method was difficult to manage and numerous crabs were lost to cannibalism or through mortalities due to variations in water quality.

Later crab pounds were equipped with floating boxes to house and protect crabs until they molted. In time, experienced producers learned to examine hard crabs for unique signs which indicated a pre-molt condition. Producers used more and more floating boxes, and relied on the selective harvest of peelers (pre-molt crabs). (Appendix 3 contains definitions of common terminology used in the soft crab industry.)

Little change occurred in the systems used to shed crabs until the 1950's when bank or shore floats were developed. Shore floats were simply shallow troughs or tanks used to hold running water pumped from an adjacent brackish-water supply. These open-flow systems were easier to manage than floating boxes and some evolved into shedding tanks roofed over to

provide crabs with shade and protection from rain and predators. Recently, attempts have been made to carry these facilities one step further with the development of closed (recirculating) systems which permit better control of water quality in shedding tanks.

All three facilities - in-water crab floats, open (flow-through) and closed systems - are in use today. Any one of the three may be the most suitable depending upon location and water quality, and each individual waterman's background, training and financial situation. Each system will be addressed separately.

Peeler Identification and Harvest

All soft-shell crab producing systems, whether traditional floats or on-shore facilities, have two basic requirements: an adequate supply of wild peeler crabs and a method of catching them. One without the other will limit production.

Peeler crabs can be identified by visual inspection. Although there are several indications that molting is approaching, the most reliable and widely used sign involves color changes associated with the formation of the new shell. These color changes also indicate the time until molting.

As the time for molting approaches, the new shell of the crab will begin to form and become visible underneath the hard shell. The new shell is most visible as a line along the inside edges of the last two flattened sections of the last leg, the paddle fins (Figure 1). The next to last segment of the leg is more often examined than the last segment. In early stages the line is white (Figure 2), indicating that the crab will molt within two weeks. As molting time nears, the indicator line gradually changes color: a pink line peeler (Figure 3) will molt within one week, a red line (Figure 4) indicates molting within one to three days. With just a small bit of practice, the soft crab producer can recognize these signs.

An additional color sign indicating imminent shedding is abdomen (apron) color. This is best seen in an immature female preparing to molt into the adult stage. The abdomen of a juvenile female is triangular in shape (Figures 5 and 6A), but becomes broadly rounded and semi-circular in shape in the adult (Figure 6B). Once an adult, female crabs normally do not successfully molt again. A juvenile female which is not yet a peeler will

have a white or creamy colored abdomen which will not change in color if the female remains a juvenile after shedding. But, an immature female approaching sexual maturity will have a pinkish purple abdomen (Figure 5). It has been suggested that some male peelers (distinguished by an abdomen shaped like an inverted-T) may also exhibit a change in abdomen color. The abdomen of some male peelers may develop a yellowish color due to the new developing shell. This color should not be confused with the yellow shell color of old, much larger, "sea-run" crabs. Few Chesapeake Bay watermen rely on male abdomen color as an indicator.

The last peeler stage is not recognized by a color sign, but rather on the physical condition of the hard shell. A split develops under the lateral spines and along the posterior edge of the shell. At this point the crab is termed a "buster" and has actually begun molting, which may be completed in another 2 to 3 hours (Figure 7).

Peeler crabs are caught with a variety of gear along the Atlantic and Gulf coasts: peeler pound net (crab trap, crab fyke, peeler trap), peeler pot, regular hard crab pot, scrape, trotline, bushline, dipnet, trawl, seine, and by hand. Each of these methods is used under different geographical and environmental conditions and legal frameworks. Descriptions of these gear types and how they are employed can be found in other publications listed at the end of this manual. In Chesapeake Bay, the predominant gear types used for the directed harvest of peelers are the peeler pound net, peeler pot, scrape and hard crab pot.

Peeler pound nets are patterned after fish pounds and consist of three parts: the hedging (or leader), the heart and the box (head) (Figure 8A). It is not well understood why peeler pounds are selective for pre-molt crabs, but location is critical. Pounds are generally placed in shallow, slow moving waters where peeler crabs are known to exist.

The peeler pound works by virtue of its placement in areas where crabs are seeking shelter for shedding (Figure 8A). Crabs moving along shore encounter the hedging, which is set perpendicular to the shore. While search-

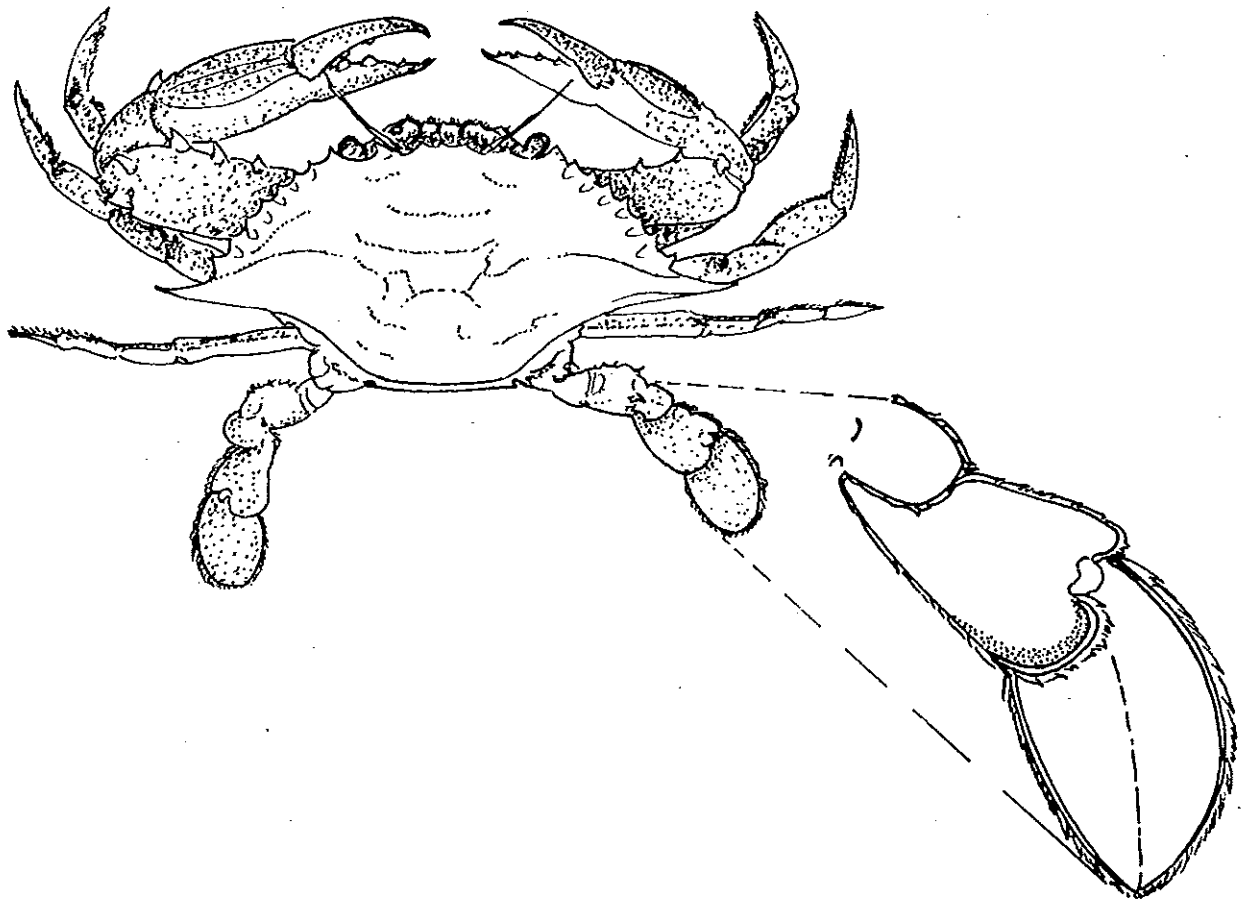

FIGURE 1. Top view of a blue crab showing differing leg shapes and location of the paddle fin. The enlarged drawing of the last two segments of the paddle fin indicates the area to be inspected in order to identify peeler stage.



FIGURE 2. White line sign on the next-to-last segment of a paddle fin. This crab will shed within two weeks.

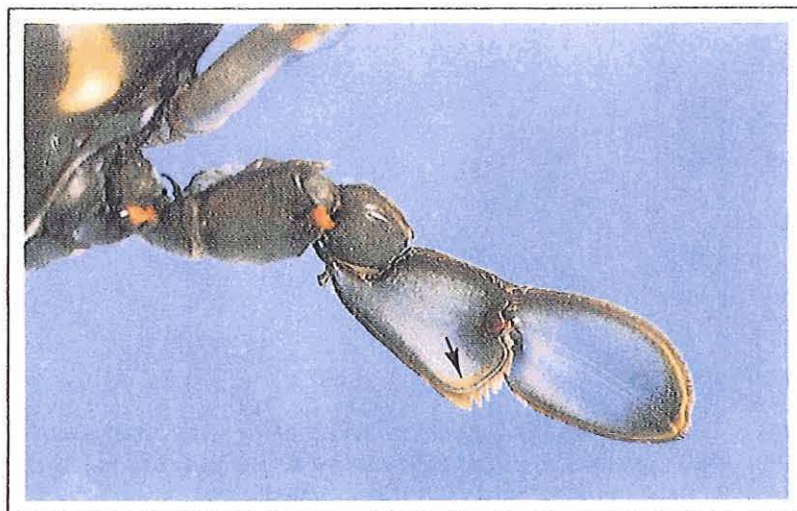

FIGURE 3. Pink line sign on the next-to-last segment of a paddle fin. This crab will shed within one week.

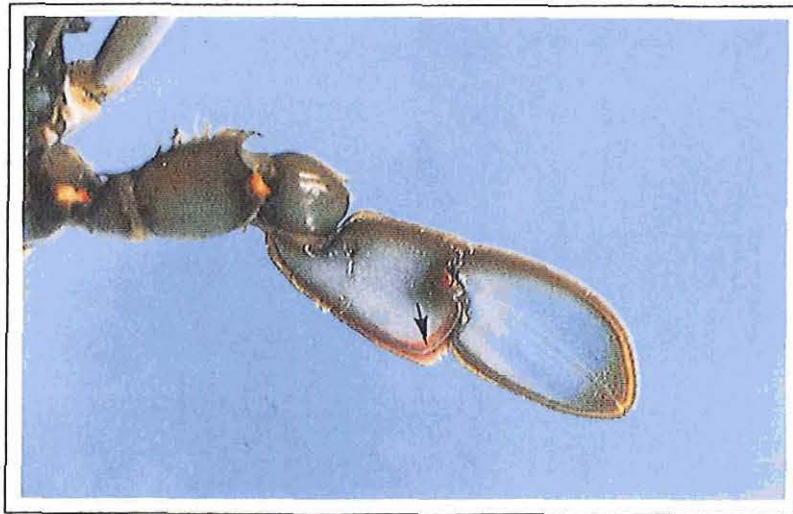

FIGURE 4. Red line sign on the last two segments of a paddle fin. Also called a rank peeler, this crab will shed within three days.

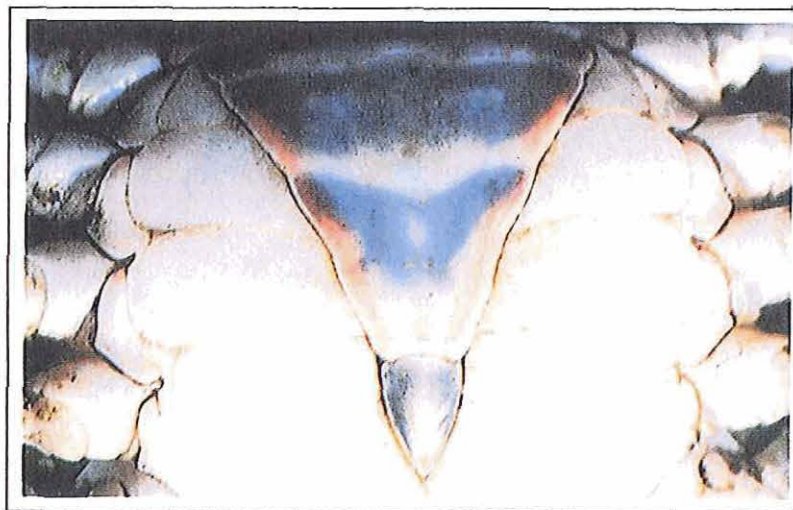

FIGURE 5. Triangular abdomen (apron) of a juvenile female showing the color sign prior to her molt into an adult. The grayish color will be carried over on the abdomen of the adult female.

A

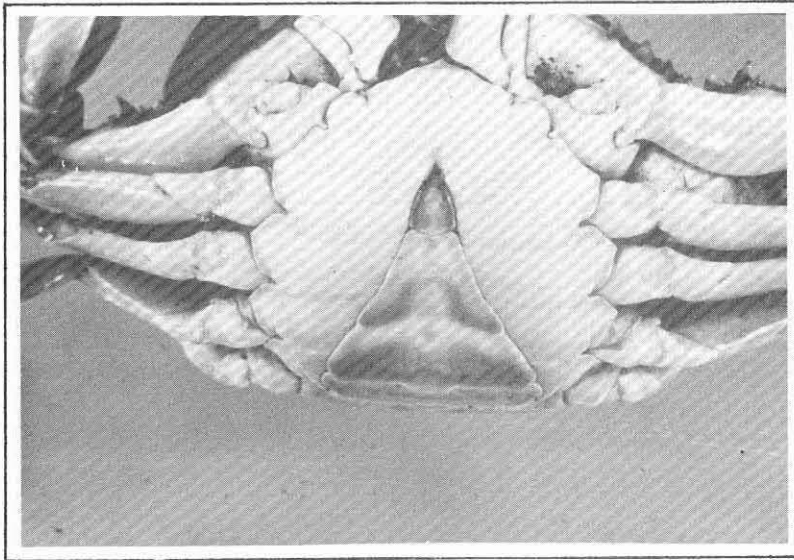
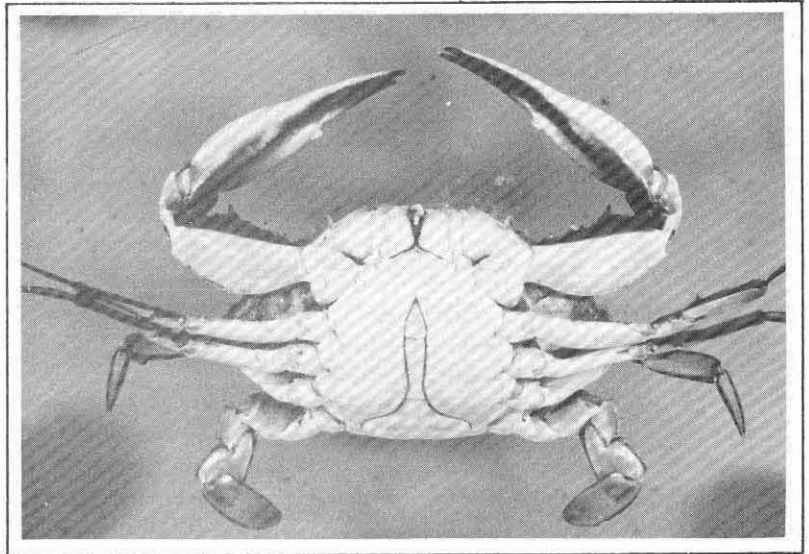

FIGURE 6. Comparison of abdomen shapes. (A) Juvenile female prior to molting to an adult. Note the grayish color in the triangular abdomen.

B

(B) Broadly rounded abdomen of an adult female. The grayish color corresponds to that seen in (A).



C

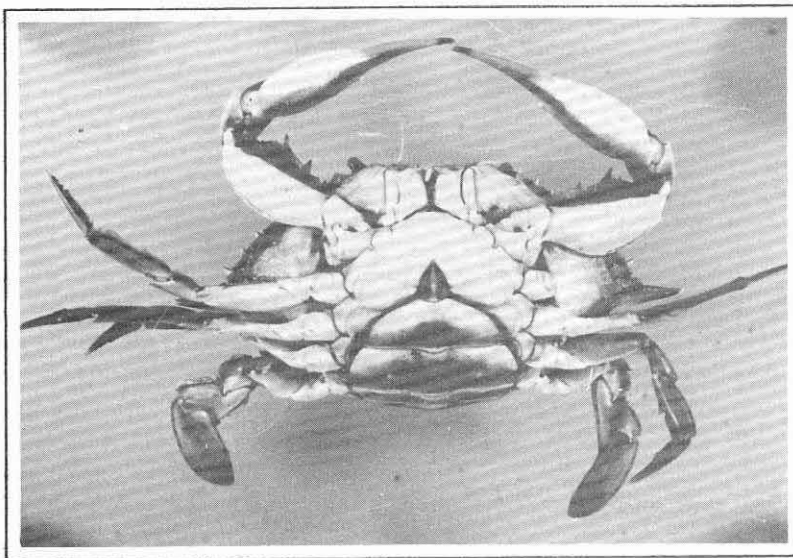

(C) Abdomen of a male crab. Shape does not change with maturity in male crabs.

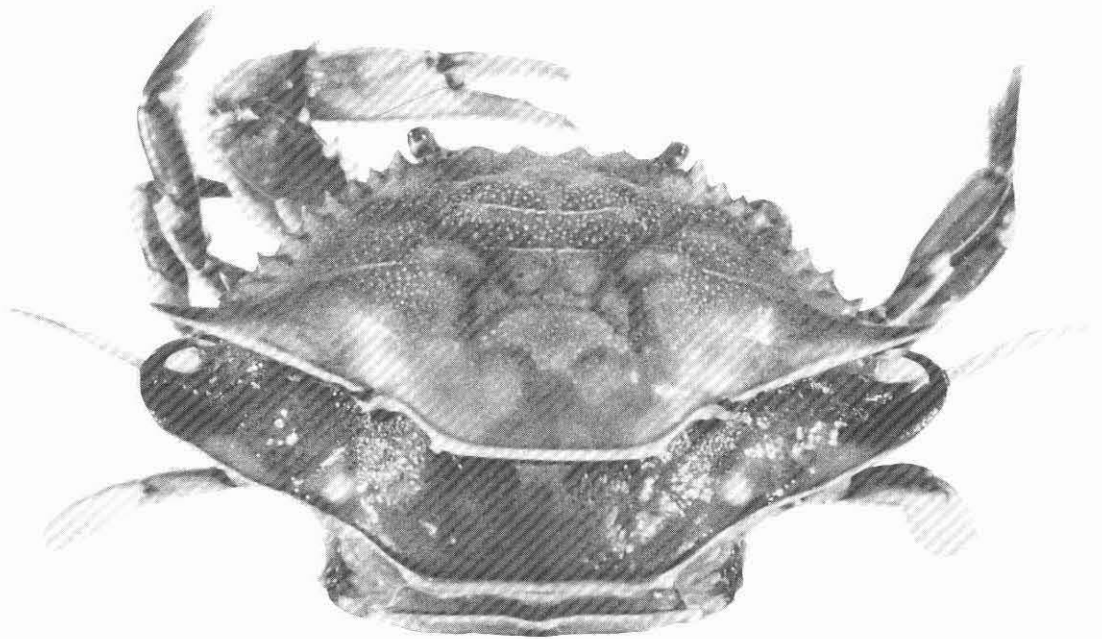

FIGURE 7. A "buster" crab. The hard outer shell has split and is opening to allow the soft crab to back out.

ing for a way around this obstruction, crabs are directed offshore by the hedging, where they eventually move into the heart. The heart continues to direct the crabs into the close-fitting entrance funnel of the box. Once inside the box, crabs are trapped until the waterman comes to remove the catch, which is usually daily.

Peeler pound hedging will vary in length, depending upon the area, water depth and bottom contour. Hedgings can be anywhere from 10 to 100 feet in length. They are most frequently constructed of galvanized wire, similar to crab-pot wire, and are staked into place. Another and perhaps better material for hedging construction is purse seine webbing (1-1/4" mesh) known as bunting. Its advantages over wire mesh are better flexibility (allowing it to follow the bottom contour) and ease of setting. A length of heavy chain is attached to the bottom of the bunting; floats on the other edge help keep it stretched into place. This reduces the number of stakes necessary to hold the hedging. By dipping this bunting in anti-fouling (copper-based) paint at the beginning of each season and carefully cleaning it following peeler season, watermen can obtain many years of usage from this type of hedging.

The heart of a peeler pound is shaped just as the name implies. Size will vary with location and individual preference. The heart is situated so that the pointed end is next to the box, at the entrance to the funnel. Hearts are constructed of 1" - 1-1/2" galvanized wire mesh and may or but usually do not have a top and/or floor. Like the hedging, hearts are staked into place.

Peeler pound boxes also vary in size. Common sizes for boxes are 2' x 3' x 4' deep, 2' x 2' x 4' deep, and 3' x 3' x 4' deep. Other sizes are also used. Boxes are constructed of a wooden frame (1" x 2" or 2" x 2" pressure treated), painted with anti-fouling paint and covered with 1" galvanized or vinyl coated wire mesh, and equipped with zinc anodes to minimize corrosion (Figure 8B).

Some watermen have begun using steel reinforcing bars to frame peeler pound boxes and hearts. The re-bar frames are very sturdy, relatively light when compared to the water-soaked wooden frames of other boxes and are not subject to attack by wood-eating animals. Properly cared for, re-bar frames will last several seasons.

The box is fitted with a hinged top for removing crabs and, on the back side (nearest the heart) below the water level, an upward pointing entrance funnel similar to that of a standard crab pot. The entrance funnel should always be made of galvanized wire. Unlike the hedging and heart, the box is not staked into place, but is left removable to permit easy emptying. It is kept in place next to the heart either by rope loops over extended heart stakes or by an arrangement of runners and cross-pieces on the box and heart (Figure 8C). Most boxes will also have a "lift-bar" attached across the top to permit the waterman to hold onto when emptying the box.

Although crab pound nets are very efficient producers of peelers they do have drawbacks. Because of their means of operation they can catch everything that encounters the hedging. This can result in peelers that are damaged due to excessive numbers of hard crabs, fish, turtles, etc., within the trap. In addition, if for some reason a particular peeler pound is no longer yielding a good supply of peelers, it is difficult to move the trap. In Virginia, each peeler pound is licensed by location, further complicating a move. They must, by law, be set at least 100 yards apart.

Peeler pound nets are not always set with the hedging tied to the shore. A pound net may be set on an offshore bar, with two or more hedges set along the bar at angles to each other and leading to a single, central box set in deeper water.

A variation of the shallow water peeler pound is the deep water pound (Figure 9). The principle of operation is the same as in the regular peeler pound, as are the basic components. However, deep water pounds are fished in water approximately 12-20 feet deep. They are generally used dur-

FIGURE 8. (A) A typical peeler pound net showing the basic parts and usual placement relative to the shoreline.

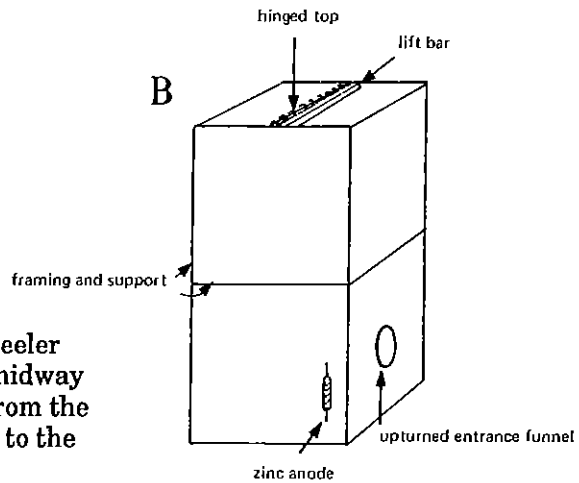
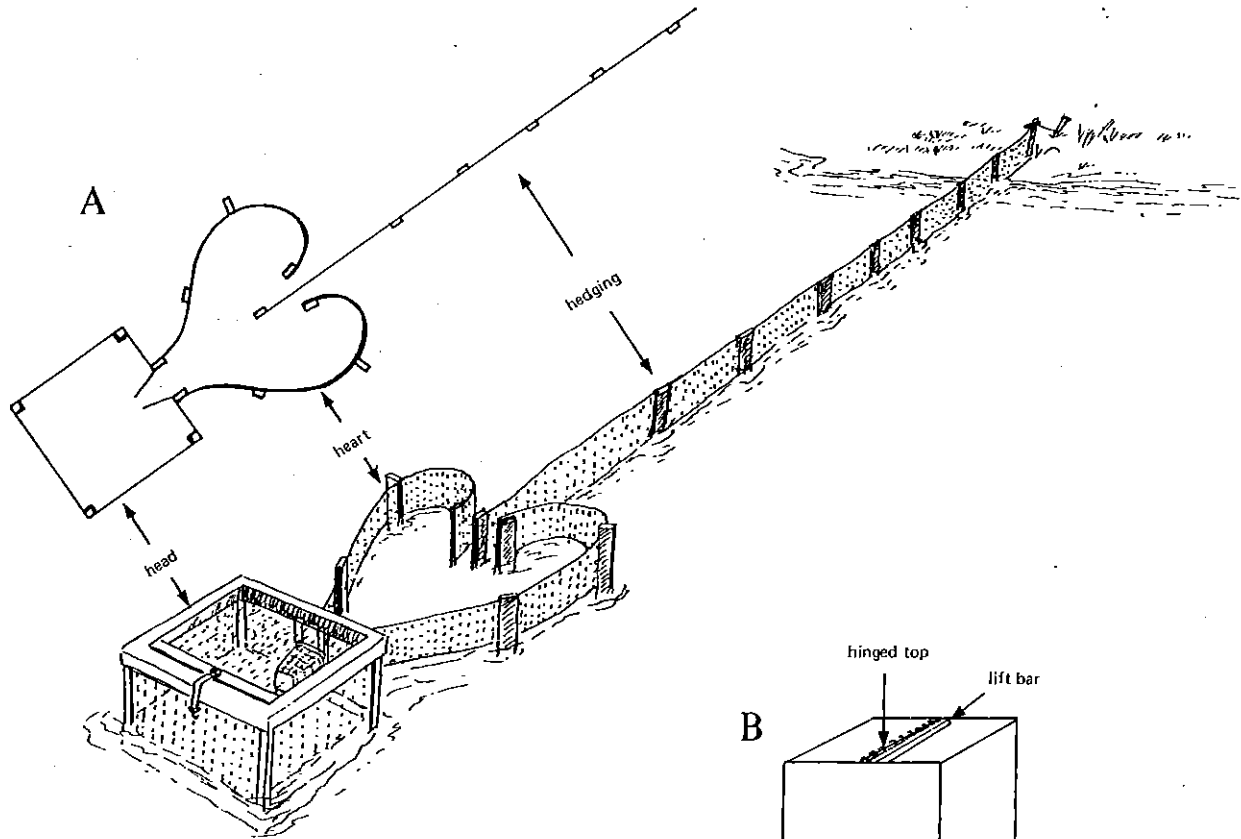

FIGURE 8. (B) Basic framing and parts layout for a peeler pound net head. Note the additions of support pieces midway up the head and a zinc anode approximately 8 inches from the bottom. Also, a lift bar of framing material is attached to the top of the head to facilitate lifting for easy emptying.

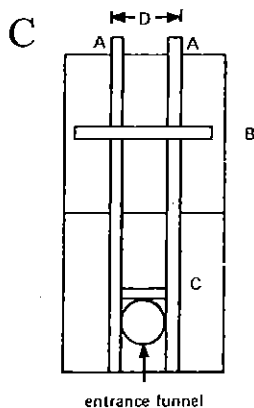

FIGURE 8. (C) Details for a runner system on a peeler pound net head to hold it against the heart. Boards (A) run the entire length of the head on either side of the entrance funnel and extend a couple inches above the top. Board (B) is attached across and on top of (A), extending several inches beyond either side of (A). This creates a space the thickness of (A) between (B) and the wire of the head. Board (C) attaches between (A)'s. The opening at the pointed end of the heart will be equal to (D). At the end there will be two boards that are the same length and size as (A). When the head is in place, (A)'s will be between the heart boards, (B) will be behind them so that the heart boards are between (B) and the wire. This arrangement will keep the head snugly against the heart.

FIGURE 9. Drawing of a deep water peeler pound net. (A) Bridle attachment for hauling. (B) Hinged door for emptying. Note that it opens from the bottom of the trap and swings upward. (C) Head portion of the trap, 48" on a side. (D) Entrance funnel from heart to head, 24" in diameter. The cross-hatched wires are to keep the funnel free of animals or debris that could block it, primarily horse-shoe crabs. (E) Heart portion of the trap, 64" across at its widest point narrowing to 24". The entire opening is 18" across with the bar for hedging attachment centered. Not shown are zinc adodes on the head and heart sections.

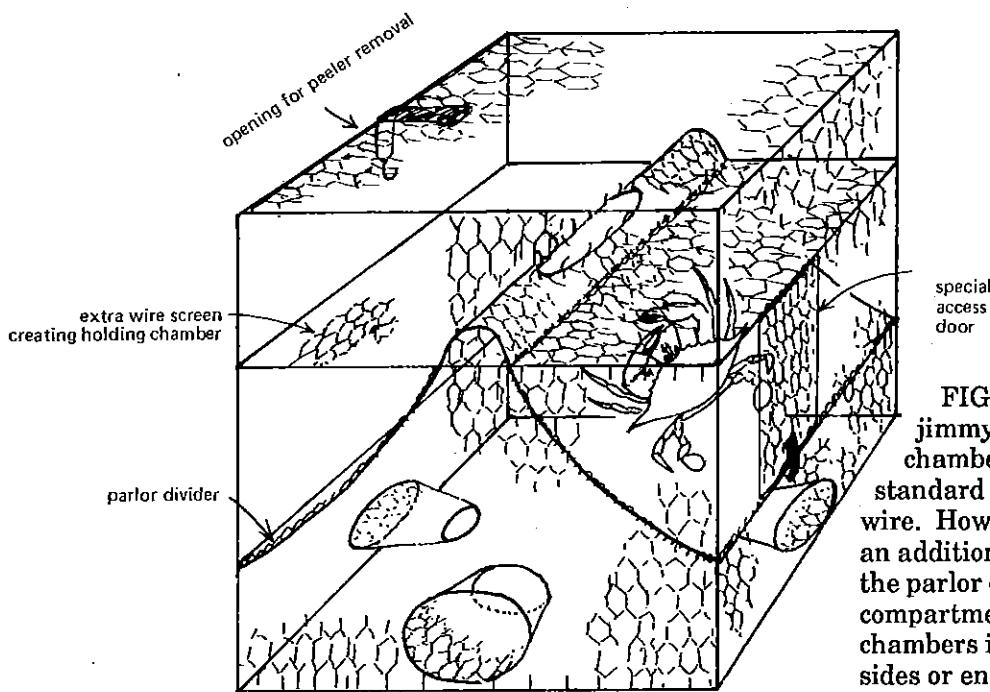
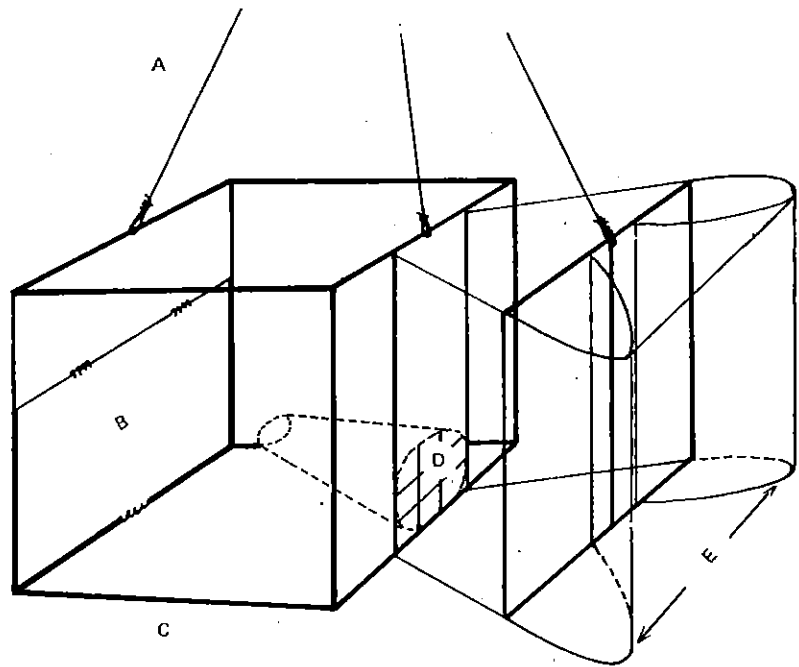

FIGURE 10. Peeler pot used for jimmy potting, with a separate holding chamber for male crabs. The pot is of standard construction using 1" mesh wire. However, there is no bait well, and an additional piece of wire is placed across the parlor divider, creating two additional compartments. Access to these holding chambers is through special doors in the sides or ends of the chambers.

ing the warmer months of summer when peelers seek out deeper, cooler waters.

Unlike regular peeler pounds that have separate parts, all the components (box, heart and hedging) of a deep water peeler pound are joined (Figure 9). The heart and box are a single unit constructed of angle iron or reinforcing rods and galvanized wire. In one design, the dimensions of the box portion are 4' by 4' by 4'; the heart portion at its widest point is 5' 4" narrowing to 2', and is 4' high. The hedging is always of purse seine bunting (1-1/4" mesh) and can be up to 90' long. The hedging is connected directly to a piece of angle iron running vertically through the center of the heart opening. Floats are attached to the top of the hedging and chain (1" links) is attached to the bottom. A single stake is used to secure the free end of the hedging.

Other deep water pound designs are also used. The most striking difference from the previously described design is the incorporation of two entrance funnels leading from the heart portion to the box portion of the pound. Additionally, the heart portion no longer has the characteristic heart-shape, but is just an extension of the box. A single opening from the hedging to the heart is still maintained.

Because of the size and weight of this piece of gear, it requires a larger boat and a winch to fish. Deep water pounds usually are set on muddy bottom at the edge of channels or drops. The hedging is set so that it runs from shallow to deep, following the contour of the bottom. It is advisable after first setting to have the entire pound inspected by a scuba diver to check for potholes under the chain, bottom debris and other obstructions to insure that the gear is properly deployed.

At certain times of the year peeler pots can be very productive. A peeler pot is quite similar to a hard crab pot in basic design; however, there are several modifications that are or can be made. While hard crab pots are constructed of 1-1/2" galvanized mesh, peeler pots use 1" mesh, so that they will retain smaller crabs. A peeler pot may or may not have a bait well.

Virginia law prohibits using fish as bait in a peeler pot. However, male crabs may be used as bait in a practice known as "jimmy potting."

Jimmy potting is most productive during spring and mid-summer when juvenile females are preparing for the transition to sexually mature adults. During these mating runs, females are attracted to male crabs. For jimmy potting, male crabs (2 to 10) are placed inside peeler pots as bait (Figure 10). There are several different techniques to hold jimmies in a peeler pot. If the pot has a bait well, jimmies can be put in it or they may be placed in the upper chamber of the pot. Other peeler pots may have special holding compartments (Figure 10). Pots in which jimmies are separated from females are thought by some crabbers to work best, since there is some indication that once a jimmy doubles, he will quit "calling" females. Jimmy potting success can be enhanced in relatively confined areas by intensive hard crab potting prior to the mating season. The removal of "wild" jimmies ensures that most of the males present for mating will be those in jimmy pots.

During other times of the year, peeler pots may go unbaited (no jimmies) in hopes of peelers entering them for protection during shedding. This bare-potting can be productive for male peelers, but experience and location are important in pot placement.

The crab scrape (Figure 11), another capture device, is a rectangular metal frame (approximately 1'x 4') with an attached webbing bag and a bridle for towing behind a boat. Virginia law stipulates that "it is unlawful for any person to: 1. Use a crab scrape having a mouth longer than four feet and a toothed bar;" (Section 28.2 - 706). Crab scrapes are pulled through grass beds where peelers and soft crabs congregate. Short tows of 5 to 10 minutes duration are made to insure good condition of peelers.

Hard crab pots are also an effective gear for harvesting early-sign peelers, those still actively feeding. Also, juvenile female peelers and adult soft crabs are often brought into crab pots doubling with male crabs which are attracted to the pot's bait.

Limited numbers of high quality peelers can be caught by hand or dip net in marshes or shallow flats. Pairs of pre- or post-mating crabs, called doublers, can be caught with dip nets on pier or bridge pilings.

Prospective crab shedders may take another approach to obtaining peelers. Rather than catching their own they may choose to purchase peelers from established crabbers. Prices to be paid for different sized crabs will be dictated by time of year, peeler availability and local demand. If the decision has been made to purchase peelers, firm commitments should be obtained from enough suppliers to assure a constant, adequate source of peelers. Initial contact with local crabbers should be made prior to any decision on purchasing peelers.

Much interest has been expressed over the use of artificial means to speed peeler development or to cause initiation of shedding. One that has been investigated and shows some potential is the use of a molt inducing hormone containing the compound ecdysone. In experimental application this hormone has sped peeler development; however, at this time no commercial usage has been attempted. There are still questions to be answered regarding hormonal usage before it gains widespread acceptance.

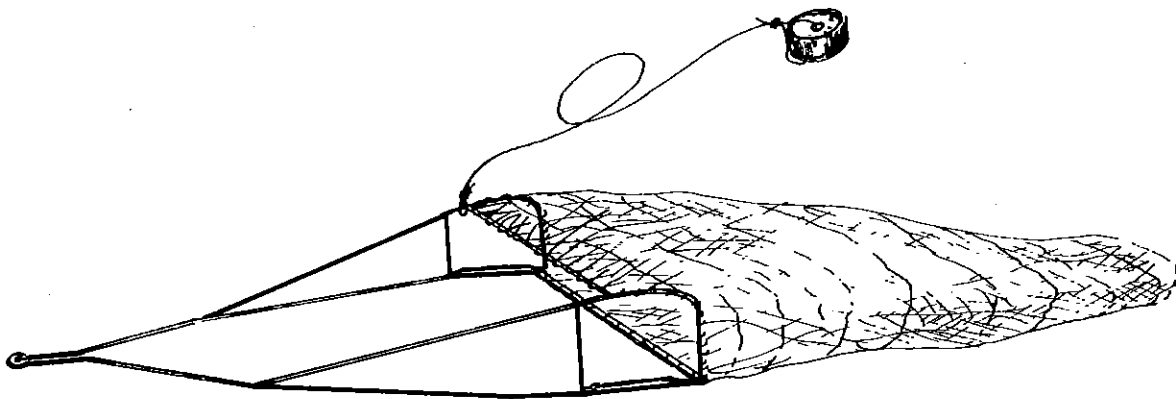

FIGURE 11. Typical crab scrape used in Virginia. The attached buoyed line permits a scrapé to be retrieved should the main towing line part or the scrape become hung on the bottom.

Peeler Care

The care with which peelers are handled during harvesting and transporting to the shedding facility will greatly affect the ultimate success in shedding crabs. Even the type of gear used to capture peelers will affect survival of the soft crab; those that are less damaging to the peeler, in terms of nicks, pinches or other puncture wounds, will produce a better quality peeler more likely to successfully complete its shed. The following gears are listed in order, beginning with the least damaging and progressing to the most damaging: by hand or dip net; doubles on trotlines; crab scrapes; jimmy baited peeler pots; hard crab pots; peeler pounds.

Peelers must be handled as gently as possible during harvest and culling. Care at this point may make a big difference in shedding success. In order to minimize puncture wounds, cutting, bleeding, and the loss of claw and legs when emptying pots or pounds, try not to shake the pot too much or dump peelers on top of each other.

Peelers should be culled during fishing with ripe (rank) crabs separated from green crabs. When packing crabs in baskets or boxes, avoid the crushing effects of weight by limiting the number of peelers in any one container. Shallow containers will help prevent over-packing. The addition of brush or alternate layering of moist sea grass or pine needles will help reduce the possibilities for injury. Boxed peelers should not be exposed to direct sunlight, but should be kept in a shaded area, as well as being covered with moist burlap or other materials. Additionally, peelers should be packed right side up, not carelessly thrown together. Packed peelers should not be allowed to come in contact with gas/oil leaks or fumes.

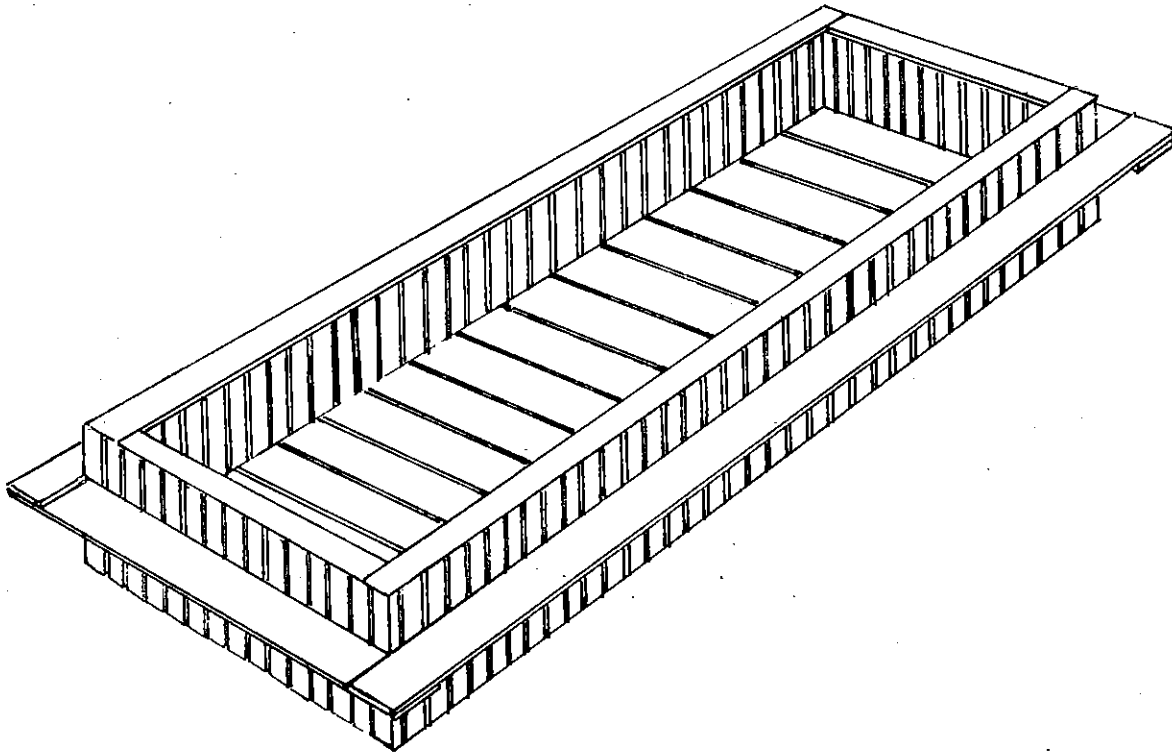

FIGURE 12. Three dimensional drawing of an in-water crab float for shedding crabs.
For dimensions, refer to text.

Facility Design and Construction

As mentioned previously, there are basically two methods for holding peelers for shedding purposes, either in-water crab floats or on-shore in tanks with a flow-through or a recirculating water supply.

The Float Operation

The crab floats of today are little changed from those existing at the beginning of the industry (Figure 12). Floats are made entirely of wood, usually pine, and are of a basic design although variations (mainly in size) are found. They often are 3' or 4' wide, 12' long and 15" - 18" deep.

Floats for white or pink sign crabs have slat bottoms of narrow boards (1" x 4" or 6") with 1/2" spaces between them to allow circulation of water through the float. For ripe peelers and buster crabs, the bottom boards are fitted tightly together. In both, the sides and ends are constructed of vertically placed laths (1-1/2" wide) with 1/4"-1/2" spaces between them. On board bottom floats, 1/4" mesh galvanized hardware cloth may be tacked to the sides and ends to prevent the entry of predators such as eels and bull minnows. A wooden shelf, 6 to 8 inches wide encircles the float at about mid-depth. This wing stabilizes the float and helps buoy it at a level preventing escape of the crabs. Bracing should be added at the top and bottom of the float for increased structural strength. Sometimes screened covers are installed to keep waterfowl, gulls, kingfishers, raccoons and other predators out of the floats, but usually floats are left uncovered.

Most float operations are located in shallow coves, harbors or inlets which are protected from excessive wind and wave action. These same locations, unfortunately, lack adequate currents; thus, circulation of water is poor. Without the proper circulation, waste products from the crabs accumulate, dissolved oxygen can be depleted and water temperature can rise to lethal levels. Natural ebb and flood tide or water currents are required to promote movement of water through the floats, and water depth must be sufficient to keep floats from resting on the bottom at low tide.

These situations can become critical during long periods of low rainfall and high summer temperatures. Since the crabs are confined to the upper 9 to 12 inches of the water column (due to the nature of the float construction), this exposure may become severe. At this depth, mortality in the floats can also occur from freshwater runoff from heavy rainfall because of the rapid change in temperature and salinity.

Most floats are painted, usually with anti-fouling paint. However, the use of paints containing copper, which is toxic to crustaceans, should be avoided. Instead of painting with a toxic compound to control fouling, floats may be removed from the water periodically as needed, scrubbed to remove the fouling plants and animals, and dried for several days to prevent rot and to destroy wood-borers. Operations employing floats will have sloping platforms or runners onto which the floats may be hauled for cleaning and drying or storage.

A commercial float operation will consist of either a wooden building ("shanty," "shedding house," or "soft-crab house") supported on pilings over the water or a shore-based building, and adjacent floats. Floats will be moored to stakes driven into the bottom at regular intervals. In some cases, a breakwater may be required to keep high waves from rocking the floats and tearing them loose from their moorings. Between stakes and suspended above the floats are lights to facilitate working at night.

The use of floats over an entire season is not widespread within the industry. In many cases floats are used only during times of peak peeler abun-

dance, mainly the first run in early summer and possibly the late summer. At other times they are used for short-term holding when all shore-based tanks are full.

Of the methods used to produce soft crabs, floats are the least expensive to construct, maintain and operate. They require no elaborate wood-working skills, and are easily built. Once in place, the only financial requirements are for labor and a small electrical charge for lighting. However, this is where the advantages cease.

There are more disadvantages than advantages to a float operation. To begin with, there is the need for waterfront property conducive to the siting of many moored floats. Second, when using floats there is no control over the environment. As mentioned previously, short-term fluctuations in temperature and salinity can cause catastrophic deaths. Crabs held in floats also are exposed to predation by animals both in and out of the water. However, perhaps the greatest drawback to a float operation is the physical difficulty associated with tending a group of moored boxes. Removal of soft crabs and empty sheds from floats, and re-sorting crabs generally has to be done from a skiff, with the operator bending over the gunnel—back breaking work, in other words. The desire for convenience, more than any other, led to the development of the shore-based facility.

The Shore-Based Facility

Either the open or closed seawater system may be employed in a shore-based tank operation, depending on the location of the facility and preference of the crab shedder. The open system is commonly used in shedding operations situated within reasonable pumping distance of a natural supply of good quality brackish water; the water is pumped into the tanks, passes through the system and is returned to the river or bay. The closed system involves the recirculation of a given volume of water within a series of tanks and filtration units. This type of facility is usually located in areas where it

is impractical or impossible to pump from a natural water supply or because of poor water quality.

There are features unique to each of these systems, but they have the same basic components and recommendations for their construction, as well as considerations designed to make the systems functional.

Tank and Supports

The most common type of tank used in the industry today is one constructed of wood, with outside dimensions of 4' x 8' x approximately 9- 3/4" (depending upon the thickness of tank floor) (Figure 13). This size is derived from the basic sizes of the materials used. The bottom of the tank is formed by a 4' x 8' piece of plywood. Although marine grade plywood is preferred and is more expensive, a good grade of exterior plywood will provide many years of service. Floor thicknesses of 1/2" to 3/4" are normal in wooden tanks. Onto the plywood are fastened sides of 2" x 10" or 2" x 12" pine. While most softwoods are acceptable for tank construction, wood such as western red cedar, Tennessee cedar and redwood should not be used as they may be toxic to crabs.

Some tanks will have an additional lip around the top edge that protrudes 2 - 3 inches towards the tank center. The purpose of this lip is to prevent crabs from escaping. However, this practice is disappearing within the industry.

When attaching the sides to the bottom, there are several alternatives available. The one chosen will depend upon finances and where the tanks will be located. The simplest method is to nail or screw the sides to the bottom board, without any sealant. Initially, leaks are unavoidable, but in many cases after water is put in the tank and the wood has had an opportunity to swell, these may cease. If the tanks are to be located where water leaks can do no harm, nailing is an acceptable method. However, if the



FIGURE 13. Typical wooden shedding tank located alongside a water source and under a covering. Notice the lip around the top edge of the sides and the placement of the water inflow at opposite corners.

tanks are to be situated where water leaks may cause problems (i.e., indoors), additional measures should be taken in building tanks.

One method for making a tank watertight is to apply a thin bead of "liquid nails" to the board prior to nailing. "Liquid nails" comes in a caulking tube, is easily applied and is waterproof when it dries. Additionally, it will provide extra holding power to the wood seams. Other sealants, such as silicon-based compounds, may also be used to help make seams watertight. Caution should be taken when choosing a sealant to ensure no toxic compounds are introduced into the shedding tank.

Tanks may be coated with various epoxy resins or fiberglass to seal them. One epoxy resin that is quite satisfactory is GLUVIT. It not only waterproofs the wood, but seals the joints and is durable enough to be scrubbed. GLUVIT is much easier to apply than fiberglass cloth and resin, another alternative, but may breakdown in sunlight unless painted or shaded.

If a tank is sealed, by whatever means, prior to operation it should be filled with water and flushed several times in order to leach out any toxic compounds.

Some crab shedders paint the interior of their tanks. If tanks are to be painted, a non-toxic epoxy type paint should be used. Light colored paints should be avoided in favor of a more "natural" color (brown, sand-colored, etc.). There is some evidence that crabs may delay shedding when placed on a light-colored (white) background. Anti-fouling paints should not be used. Any painted tanks should always be flushed with water prior to using.

Although wooden tanks are the easiest to construct, those who want to invest more money initially on permanent equipment should consider the construction of concrete (cinderblock) tanks or purchase of gel-coated fiberglass tanks (Figures 14 and 15). Concrete tanks, however, have several disadvantages. Once they are set they cannot be rearranged without some demolishing and they require a coating of a non-toxic epoxy resin as a sealant. Fiberglass tanks, on the other hand, are relatively lightweight,

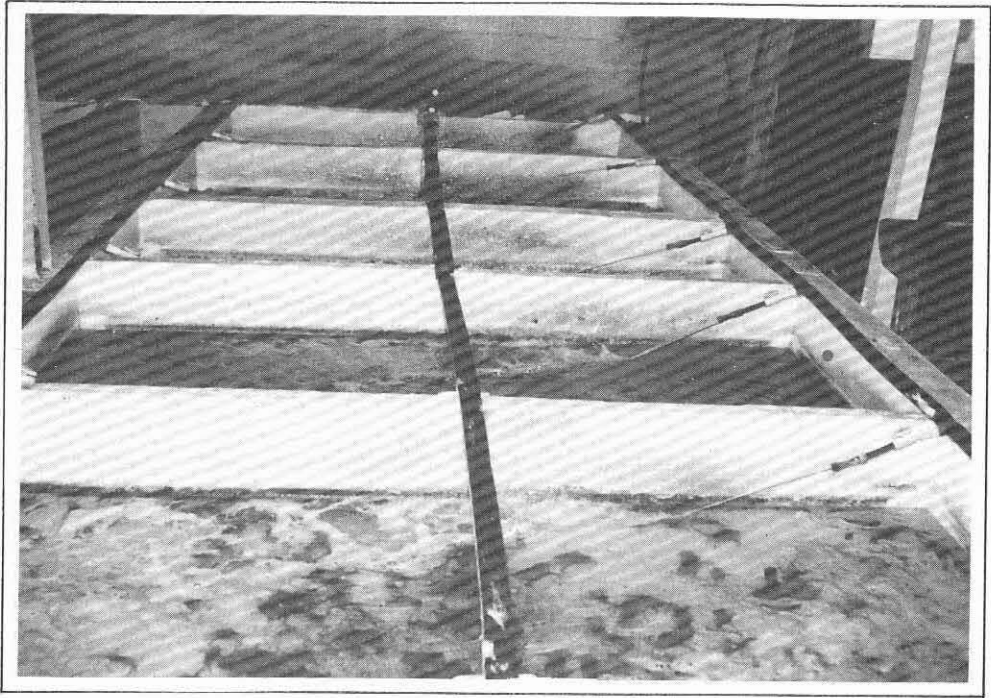

FIGURE 14. Concrete block shedding tanks arranged along a floor inside a building.

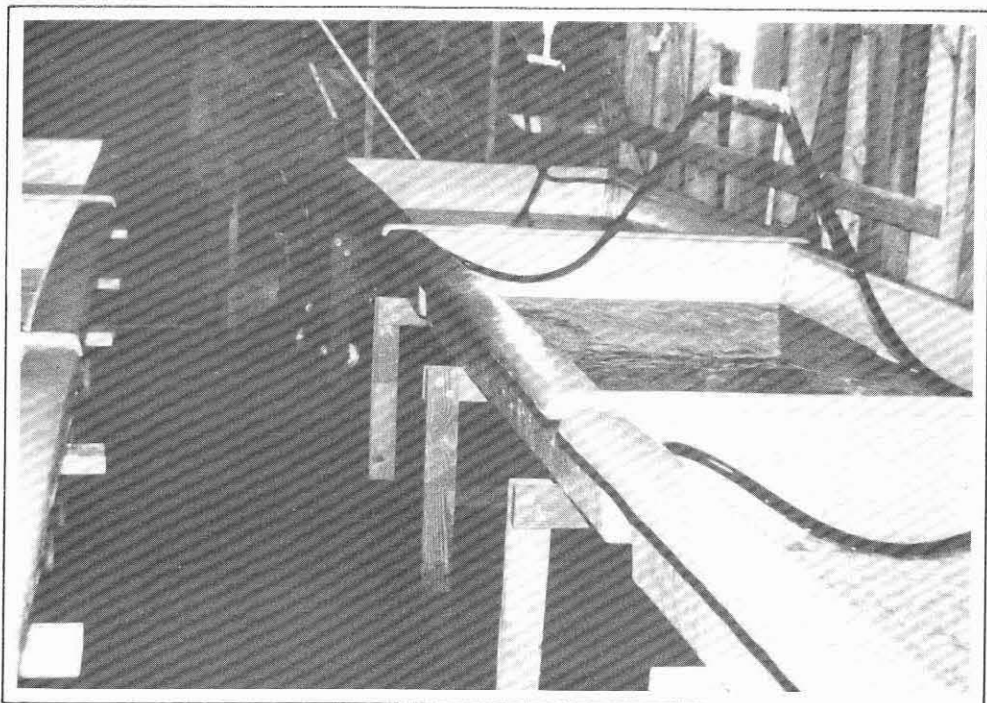

FIGURE 15. Example of commercially produced fiberglass shedding tanks.

quite strong, require no painting and, with reasonable care, should outlast wooden tanks. Fiberglass tanks are available from commercial sources. They are, however, considerably more expensive than wooden tanks, costing between \$200 and \$300 each.

There is no specific design required for tank support. Some shedders use trestles or sawhorses; some place the tanks on pilings; concrete tanks are built right on the floor. If a table or other support method is desired, it should be ruggedly built and reinforced according to the size of the tank it will support. A cubic foot of water (7-1/2 gallons) weighs 62.4 pounds. The weight of water in a 4' x 8' tank with the recommended water depth of 4" (approximately 80 gallons) is nearly 660 pounds (Appendix 4).

If a table support is to be used, it should be constructed with six 4" x 4" legs bolted to an upper framework of 2" x 6" lumber. Additional strength is provided by an internal cross-bracing of 2" x 4" boards fastened to the 2" x 6" skirt.

For convenience, the top of a tank should be approximately 30" from the floor, or about waist level. Double-decking of tanks can also be done, with one tank supported above the other, if additional bracing is provided.

Pump

The size of the pump will depend on the volume of the overall operation. It is necessary, however, that a sufficient circulation and turnover of water be maintained in order to aerate the water and to remove toxic waste products. Some of the factors which must be considered in choosing a pump are (1) vertical suction lift from water to pump, (2) the length and diameter of this suction line, (3) whether or not a strainer is employed on the suction line, (4) the vertical discharge head from the pump, (5) the length and diameter of the discharge line, (6) the number and type of fittings (elbows, T's, etc.) in the system, and (7) the desired flow rate. Pump manufacturers can

provide prospective buyers directions and formulae to allow them to utilize these factors and make a decision on pump size.

Pumps currently used by the shedding industry are of two types, centrifugal or submersible, generally high volume - low pressure, and are self-priming. Many commercial brand name pumps of these types are available (Sears, Gould, Teel, Wayne, to name a few). Whatever brand is chosen, replacement parts should be readily available locally. In addition, the impeller and other internal pump parts which contact water should be of a non-toxic material such as plastic or stainless steel. Copper, monel metal, zinc or lead should not be employed in any water contact parts. Submersible pumps have been increasing in use at shedding facilities located directly next to the water source and where there is little head pressure to restrict their pumping capabilities. They can deliver large volumes of water when not restricted by back pressures and are almost maintenance-free once in place.

The higher the rate of water turnover, the better conditions will be for the crabs. In a 4' x 8' tank with 4" of water (about 80 gallons), it is recommended to replace all the water in the tank every 12 to 20 minutes, or 3 to 5 times per hour. For 3 water replacements per hour (240 gallons), a flow rate of 4 gallons per minute per tank would be required; at 5 water replacements per hour (400 gallons), a flow rate of almost 7 gallons per minute per tank would be necessary. For a 10 tank facility to achieve 3 water turnovers per hour, its pump must be capable of delivering 40 gallons per minute. (Appendix 4 explains how to determine the amount of water in a shedding tank.)

The most popular size pumps in use today are 1-1/2 Hp and 2 Hp. This size pump is capable of supplying a sufficient water volume to 10 to 20, 4' x 8' tanks with 4" of water. The actual number of tanks on a single pump will depend upon the previously mentioned factors. Facilities utilizing more than this number of tanks must add additional pumps accordingly. It is probably best to maintain pump-tanks integrity so that sections of the facility may be brought on and off line, depending upon peeler availability.

Plumbing and Flow-through Considerations

Just as important as the pump are pipes, plumbing fixtures and the way the entire facility is laid out. This section will cover the basics of plumbing and water circulation for a flow-through tank. These basic construction principles will also apply to recirculating systems.

All piping and related fittings should be corrosion resistant and of non-toxic material, the most popular of which is polyvinyl chloride (PVC). Not only are PVC materials non-toxic, but they are readily available, easy to work with and come in all shapes and sizes. Because of PVC's popularity in other industries, every fitting, valve, nozzle, etc., that would be needed in a crab shedding facility is available.

Determining the size pipe (internal diameter) to be used will depend upon your pump selection. Pipe diameter from the water source to the pump and then from the pump to main water distribution lines will be determined by the respective openings on the pump. Normally pipes with internal diameters of 1-1/2" or 2" are used for input water and main distribution lines. Then, by using various couplings, diameters can be reduced down to 1/2"-1" at the point of delivery to the shedding tanks. Care should be taken, however, as pump delivery rates can be significantly reduced by too small delivery lines in which friction occurs and back pressure on the pump is applied.

The water intake of the system should be placed in the deepest water possible. A deep location is preferable because the water is usually cooler and has a more constant salinity than in a shallow location. The intake should, however, be suspended at least a foot above the bottom so that mud and sediments are not drawn into the system. A screened box surrounding the intake is recommended, with the possibility of using two different screen mesh sizes (e.g., two screened boxes over intake) (Figure 16). The outer screen would be of 1" mesh wire (like crab pot wire), while the inner screened box would be of 1/4" hardware cloth. The outer screen would catch

larger pieces of debris, the inner smaller pieces. Intake screens must be cleaned or replaced periodically to prevent disruption of flow into the pump.

When situating the pump and water intake, it should be remembered that it is easier for a pump to "push" water than to "pull" it. Therefore, the pump should be located as close to the water source as possible. Also, the intake should be located as far away from the discharge from the shedding tanks as possible. It would be detrimental to the entire system if the deoxygenated, waste-laden outflow water were to be picked up in the intake and recycled.

Surface fouling organisms (barnacles, sea squirts, oysters and other encrusting animals) can set in pipelines and seriously impede water flow. Periodic shutdown and backflushing with fresh water will kill the organisms and free the lines. Also, the system can be shut down and water be allowed to stand in the pipes for about a week to become deoxygenated (go anaerobic), thus killing the fouling organisms which can then be flushed from the lines. Fouling organisms can also be mechanically removed by including removal caps in the plumbing, so that a brush or other reaming device can be run through the pipes.

In the Chesapeake Bay area, frequent shutdowns may be necessary for ridding pipes of fouling organisms. Since this may not be practical with a single pump and line system, a double system may be needed. The dual system allows one set of pump and lines to be placed in operation while the other set is being cleaned.

It is essential to achieve good water circulation within individual shedding tanks. This will ensure that oxygenated water is supplied to all portions of the shedding tank, as well as provide for the removal of waste materials. Therefore, the introduction of water to the shedding tanks and subsequent discharge should be designed to provide good circulation.

There are several ways currently employed by industry members for water inflow and drainage within shedding tanks (Figures 17 and 18). The most prevalent means of water introduction is by overhead spray. Water is

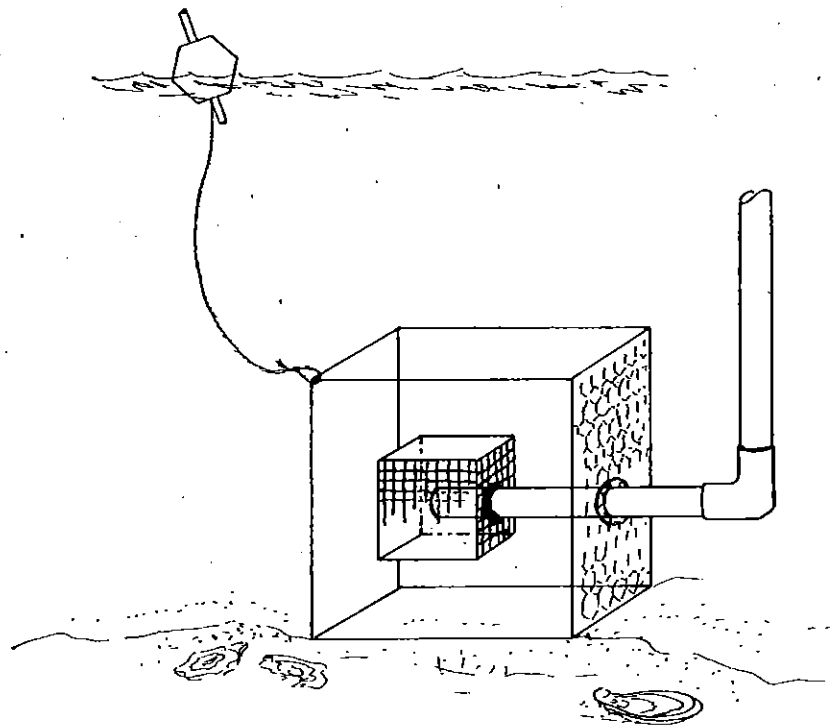

FIGURE 16. Construction details for a two-box screened water intake. The smaller, inner box should be constructed of small mesh wire (1/4"). The larger outer box should be larger mesh (1"). A buoyed line is attached to allow for raising the screened intake for periodic cleaning.

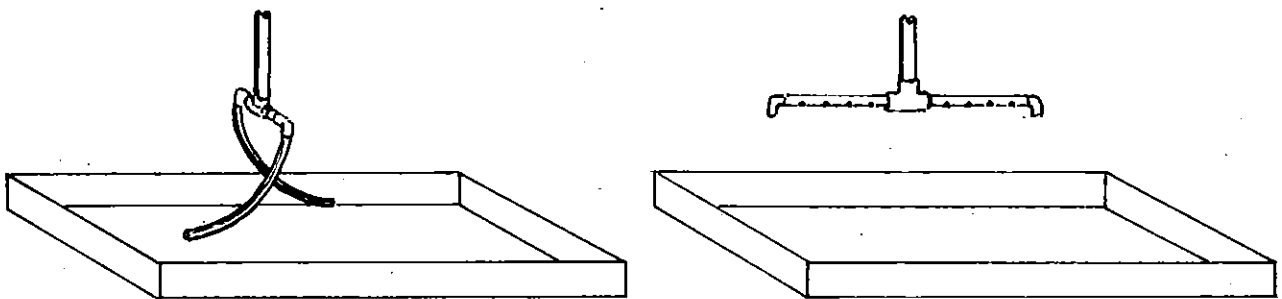

FIGURE 17. Examples of overhead water introduction into shedding tanks. An even simpler method is a piece of PVC pipe with holes drilled in it, extending over all shedding tanks. A disadvantage is not being able to control water going to individual tanks.

sprayed down vertically or at a slight angle in single or multiple streams. These can come from short supply pipes or from holes drilled in an overhead pipe. This method agitates the surface, mixing air with the water. Its disadvantages are that it does not encourage circulation of water in the tank and that valves located overhead are often difficult to reach.

Since water is introduced to the tanks under pressure, modification in the plumbing can be made in conjunction with a variety of fittings to implement not only the direction of flow of water in the tanks, but also the introduction of oxygen. Systems employing aspirator valves in the section of pipe supplying each tank are another means of aerating water. Commercial aspirators are available or can be built out of easily obtained materials.

A simple aspirator can be built by adding a T to the inflow at the tank (Figure 19). The arm of the T should point upward. This arrangement allows air to be sucked into the water as it moves by the T's opening.

One method of water introduction that has proven very successful for obtaining good water circulation involves below-surface or just above surface inflows at opposite corners or sides of a tank (Figures 18 and 20). This creates a circular motion within the tank, eliminating dead spots. It also tends to concentrate silt and debris (crab parts and wastes) in the center of the tank, making for easy cleaning. This is especially true if a center drain is used.

Water can be drained from tanks by holes either in the bottom of the tank with stand pipe drains or through the sides of the tanks with overflow pipes. Regardless of the methods used, water depth in the shedding tank is regulated by the drain. It is necessary to have only enough water to cover the backs of crabs, about 4".

Overflow pipes can be of two types. The more simple one is a straight piece of pipe through the side or end of a tank at the desired water depth (Figure 21A). When water reaches that level it merely flows out. In some cases this flow goes directly to another shedding tank or tanks, prior to being eventually discharged overboard. The other overflow method involves

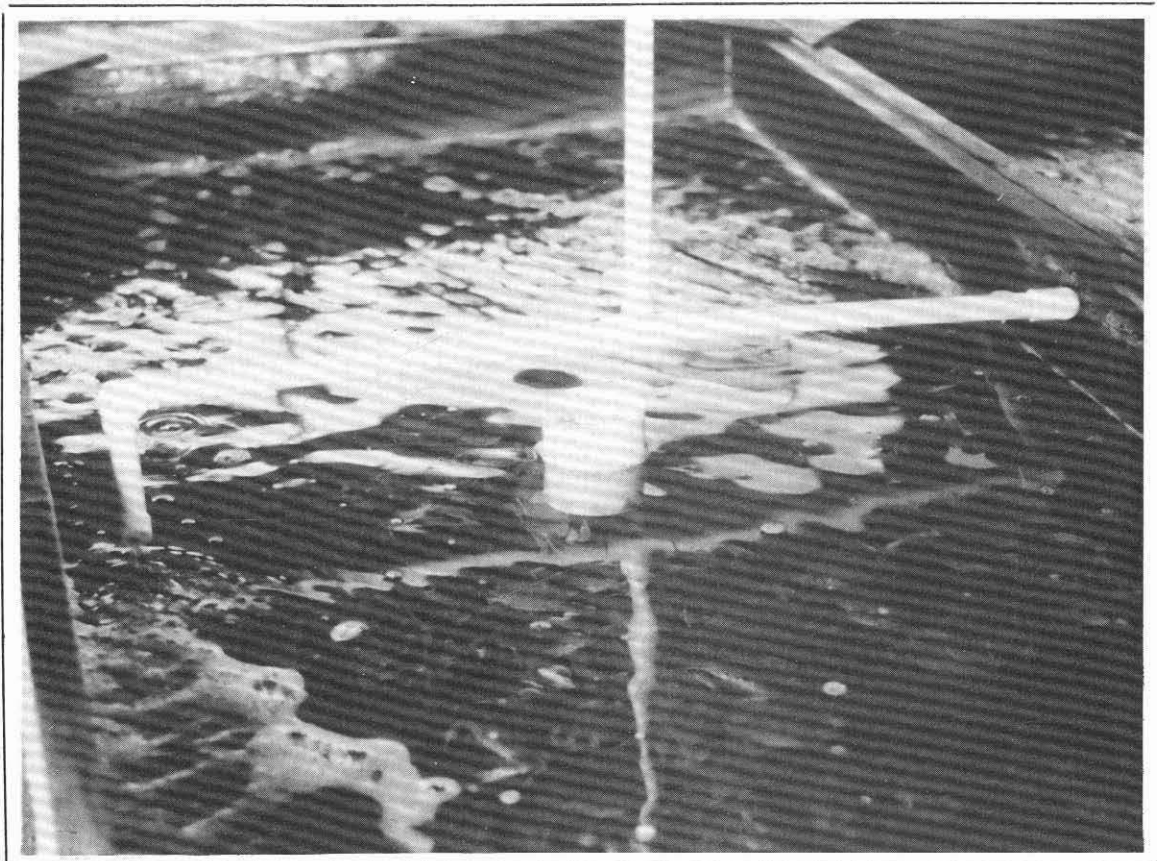

FIGURE 18. Example of a countercurrent water input. Water is supplied from an overhead main delivery line. At each shedding tank a branch line drops to within several inches of the water surface. A valve for water regulation is included in the branch line. By using various fittings (T's, elbows and caps) water is sprayed in opposite directions, creating a swirling pattern. Note the center double pipe design drain (see Figure 22B).

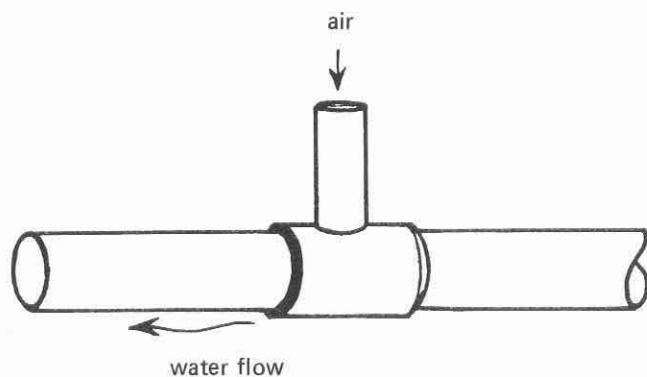

FIGURE 19. A simple T-aspirator. More elaborate aspirators can be purchased or constructed using reduction couplings and special parts. A detailed description of an elaborate aspirator can be found in Perry, et al.

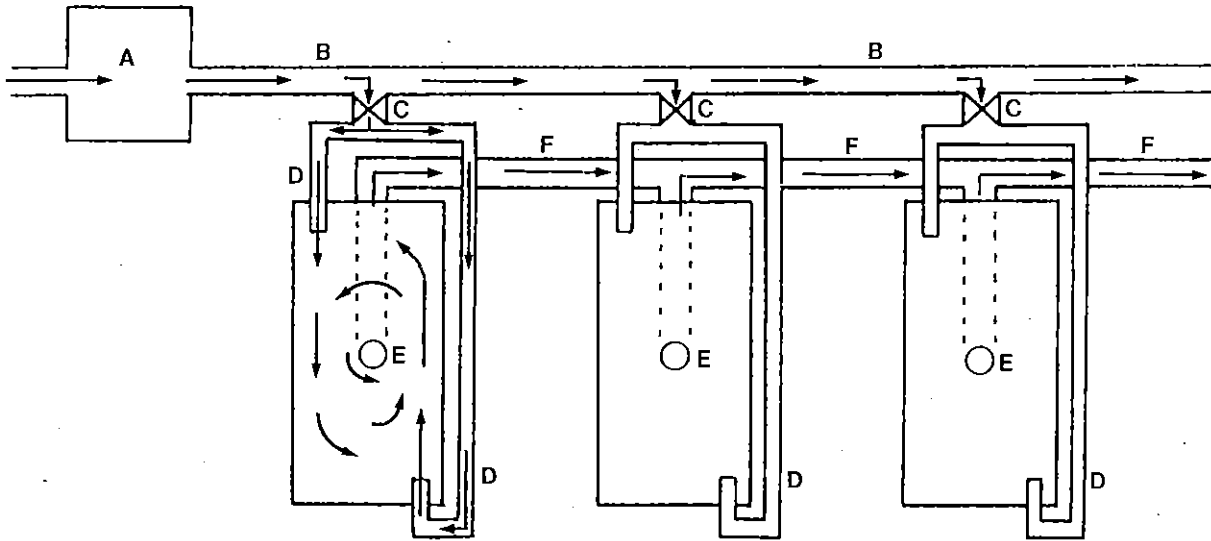
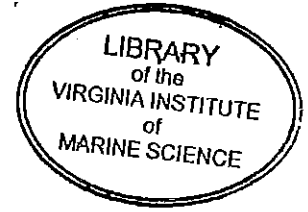

FIGURE 20. Layout for a flow-through shedding system employing dual water injection and center drain for optimum water circulation. Arrows indicate direction of water flow. (A) Water pump. (B) Main water delivery line. (C) Valve with reduction coupling. (D) Tank water delivery line. (E) Tank standpipe drain. (F) Main drain line.

an elbow and moveable arm (Figure 21B). A piece of pipe goes through the end of a tank near the bottom; to this is attached, but not sealed, an elbow; into the elbow is placed another piece of pipe. With this arrangement, water depth can be regulated by the angle at which the attached pipe is set.

Water depth (and drainage) is most commonly regulated by means of a standpipe drain. Drain pipes are usually 1-1/2" - 2" in diameter. Water level is controlled by the height of the pipe. Standpipes can either be a simple, single-pipe or a double-pipe arrangement. With a single-pipe, water will be drawn off the surface, allowing silt and pieces of debris to settle and collect within the tank (Figure 22A).

The double-pipe drain causes water to be drawn from the bottom of the tank, thus creating a self-cleaning system (Figure 22B). To construct a self-cleaning drain, begin by installing a single standpipe of the desired height. Next take a piece of pipe 2" to 4" inches larger in diameter and approximately 2" longer than this first pipe. In the larger pipe 1" saw-tooth notches should be cut around one end. This larger pipe is now placed over the smaller pipe with the notched end down. The inside pipe will still regulate water depth, but now water and silt will be sucked out through the notches in the bottom edge of the outer pipe, will go between the two pipes and then over the top of the inside pipe.

Water level controlling standpipes can be affixed to the shedding tanks by several methods. The easiest is simply to drill a hole in the bottom of the tank the same size or slightly smaller than the outside diameter of the stand pipe. The standpipe is then just forced into the hole. Sealing devices such as through-hull boat fittings or other plumbing fixtures (for example, shower drain connectors) can be placed in the tank bottom and then the standpipe inserted. PVC coupling fittings are also used. Standpipes, however, should not be sealed or glued so as not to be removable.

Whichever standpipe system is used, it should be easily removable for flushing. Additionally, a 1/4" hole should be drilled about 1" from the bottom of the pipe which controls water depth. This will act as an emergency.

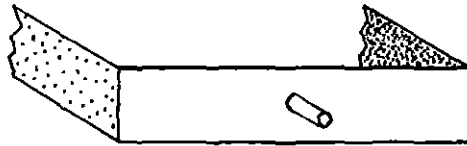

FIGURE 21. (A) Simple overflow pipe through the end of a shedding tank. Pipe placement regulates depth, but is unchangeable.

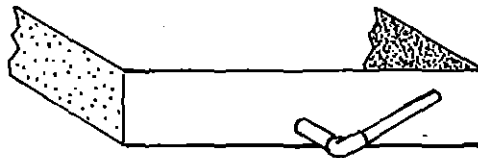

FIGURE 21. (B) Overflow pipe employing a movable arm and elbow. By changing the angle of the arm-elbow, water depth can be regulated within the shedding tank.

drain should water flow stop from an electrical or mechanical failure. Crabs completely submerged in still water can quickly deplete available oxygen and die. However, if held in only enough water to keep their gills moist, they will be able to "bubble" and receive atmospheric oxygen. Some shedders with recirculating systems have chosen not to include the emergency drain for fear of water loss from the system in the event of power outages.

Placement of the drain should also be considered when designing for good water circulation. Avoid placing drains directly under or in the path of incoming water. If water is coming in from overhead, determine the furthest point from the inflow and place the drain there. When water enters from opposite corners, as mentioned previously, a center, self-cleaning drain is recommended. In this configuration silt and debris are moved towards the center and then drained from the system.

Water leaving individual tanks can be returned to the original water supply by means of pipes, channels, or ditches, depending upon shedding facility location. If piping is used, it should be of sufficient internal diameter to handle the volume of water leaving, as well as having air space left over. This will prevent drain water from backing up. For example, assume a 2" standpipe drain; under the shedding tank would be another length of 2" pipe emptying into a main drain line of 4" to 6" diameter which collects water from several or all shedding tanks. Drainage is by gravity flow.

When assembling the entire shedding facility, it should be remembered that elbows, T's, or other bends and angles all tend to impede water flow by increasing friction. The ultimate result is a reduced flow rate. Although these fittings are necessary, they should be held to a minimum.

It will be desirable to have some control valves within the system. Points where they may be located are at water inflows to individual tanks to help regulate flow rate or to facilitate culling by turning off the water supply; at main distribution lines to a series of tanks in order to take a number of tanks out of service; or at the pump to regulate water flow; however, the last option is a very inefficient means of water regulation. As with every-

FIGURE 22. Standpipe drain construction options.

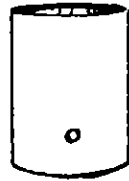

1/4" hole, 1 inch from bottom for emergency drainage

(A) Single piece of PVC pipe cut to the desired water depth (about 4") draws water from the surface for drainage. It should be removable to facilitate total drainage or for tank cleaning.

serrations all around base

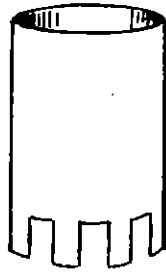

OUTSIDE PIPE

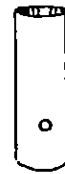

INSIDE PIPE

1/4" hole, 1 inch from bottom for emergency drainage

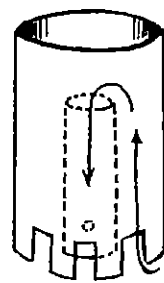

TOTAL SYSTEM

(B) Double pipe design. A 2-pipe system where water depth is controlled by the inner pipe, the outer pipe insures that water is drawn from the bottom, thus helping to remove mud, excreta and other debris. Both pipes should be easily removable for total drainage and tank cleaning.

thing else in the system, any valves used should be of non-toxic material construction.

It is desirable to have the shedding facility under a roof or covering of some kind to provide shade (helping in temperature control and to reduce algal growth in tanks) and to eliminate problems from rainfall. You will also be better able to protect your investments from predators or poachers. Overhead lighting should be kept to a minimum and only used when necessary to harvest soft crabs or culling. Otherwise, keep it turned off.

A final word on facility construction: learn to be your own carpenter, plumber and electrician. Being able to do most or all of the construction on your facility will save you money. Likewise, you'll be able to handle repairs on your own-try finding (or affording) a plumber to make a house call at 2:00 a.m.!

Closed System

During the past few years a great deal of interest has been generated over the use of closed (recirculating) water systems for crab shedding. A closed system is essentially a large aquarium for holding shedding crabs. All construction parts and considerations mentioned in regard to flow-through systems apply to closed systems as well. Closed systems offer several advantages over traditional methods. Foremost among these is better control over environmental factors: salinity can be maintained at a constant level; temperatures can be kept lower than those of natural waters; there are no dangers from pollutants or siltation; and, water clarity can be increased. A closed system may also free one from the necessity of having costly waterfront property. Closed systems can be constructed most anywhere. However, a closed system has disadvantages as well. It is more complex and costly to build and maintain than a flow-through system, and since there is no overboard discharge, constant attention is required for the control of toxic wastes added to the system by crabs.

Crabs continue their normal bodily functions of respiration and excretion in the closed system. Respiration can result in increased levels of carbon dioxide and decreased levels of oxygen in the water. Excretory products can become toxic to peelers and soft crabs. These materials must be removed for the health of the crabs. This means filtration, defined in its broadest sense.

There are three general types of filtration that can be used in a closed system: biological, chemical and mechanical. In any one system, a combination of these will prove effective. However, of the three, biological filtration is by far the most important.

Biological filtration is the conversion of toxic nitrogenous waste products into less harmful compounds by bacterial action within a filter bed. This occurs in a step-wise process identified as the nitrogen cycle (Figure 23). The first step in this process is the conversion of organic nitrogen (waste products, proteins and amino acids) into ammonia. Ammonia is then further processed by bacteria into nitrite, and nitrite into nitrate. Both ammonia and nitrite are toxic to peelers at relatively low concentrations, approximately 7 and 1 parts per million (ppm) respectively. Nitrate is much less toxic than ammonia or nitrite, requiring concentrations hundreds of times greater to cause mortalities. The bacteria which accomplish these conversions are known as nitrifying bacteria, and are the mainstay of any biological filter.

Nitrifying bacteria have certain requirements for growth and reproduction. They are aerobic, meaning they need oxygen to survive. It is important to note that the bacteria in a properly functioning filter may actually consume more oxygen than the crabs in the system. Oxygen levels of 4 ppm or greater are necessary to maintain bacterial growth. Nitrifying bacteria are also surface dependent and surface limited. This means they require a substrate to grow onto, and that the more surface area available, the more bacteria can be supported. They are also pH sensitive, preferring more of a neutral (pH 7.0) environment to an acidic (less than 7.0) or alkaline (greater

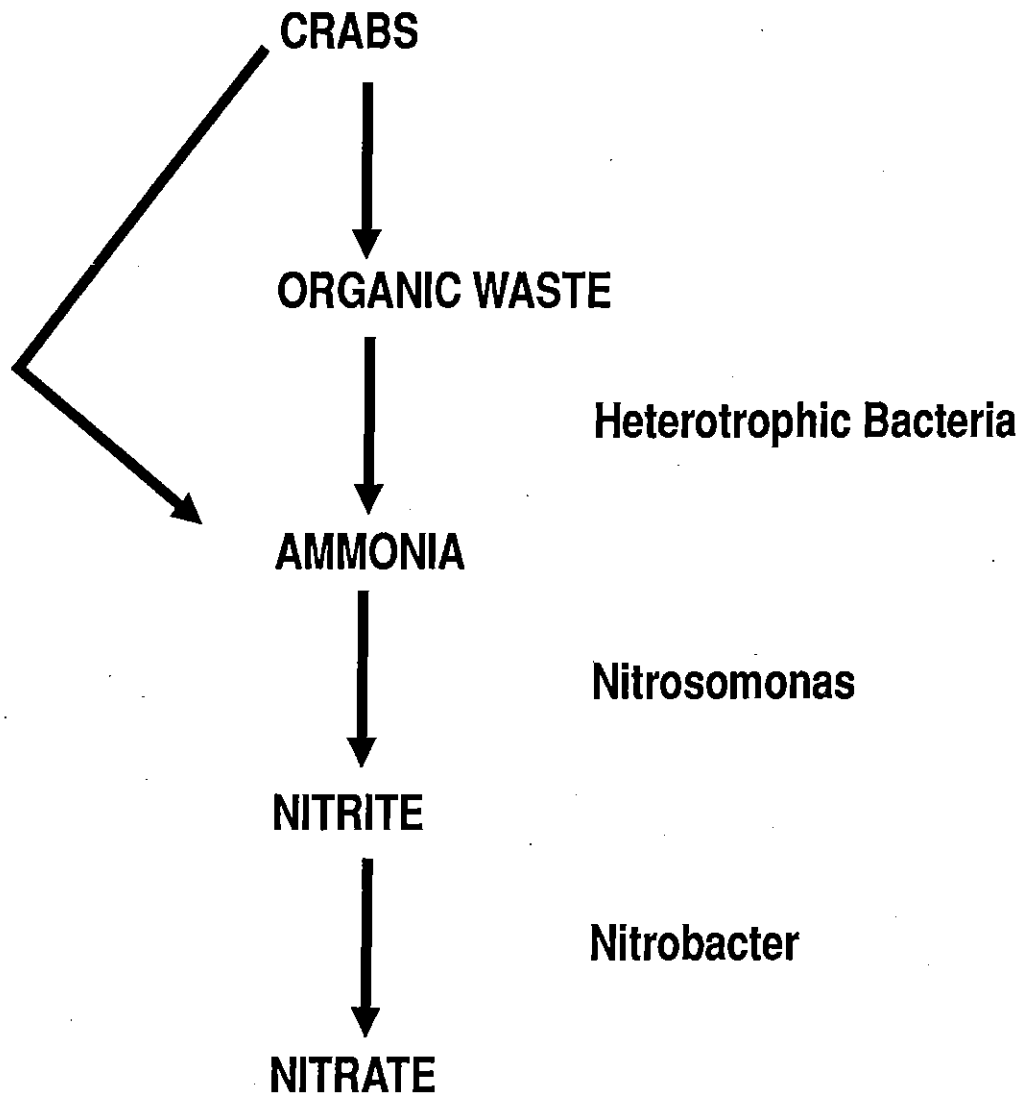

FIGURE 23. Pathway for nitrogen breakdown (nitrogen cycle) within a biological filter.

than 7.0) one. Finally, they are slow growers, taking weeks to build up their numbers under the best of conditions. This point is important when starting a biological filter.

Recent research has indicated that as many as 30 days are needed for a filter to become ready (conditioned) to receive peelers (Figure 24). This means that the closed system must be started and the biological filter conditioned in advance of when peelers are to be added. The necessary filter bacteria occur naturally in brackish water as well as in soil. To shorten the time required for the filter to become conditioned, use natural sea water and add soil nitrifying bacteria. To obtain soil bacteria, put some garden soil in a jar, fill it 3/4 full of fresh water, and then shake vigorously. After the soil has settled, the water containing bacteria can be added to the system. Another method to speed the establishment of filter bacteria is to obtain filter material and water from an established recirculating system. In recent years commercially produced bacteria "soups" have become available. There is some evidence that use of these products may speed conditioning. Experience has also shown that regular additions of these products to biofilters has a beneficial effect on the filters. It has become common practice among users of closed systems to once a week add approximately one ounce of these products to their biofilters to assist in maintaining healthy bacterial populations.

Just adding bacteria to a filter is not enough. In order for them to grow and reproduce, they must be fed. In other words, waste materials must be supplied to them. Turtles, catfish and hard crabs are less affected by ammonia than other fish or shellfish and when placed in the system will supply the necessary wastes that are sources of food for the bacteria. When conditioning a biofilter it is necessary to gradually increase the animal "load" within the system. Initially, only a few animals are added to the system. Then, at regular intervals of several days, the numbers of animals are increased until the carrying capacity of the filter is reached. Carrying capacity refers to the total number of animals that the system is able to safely

hold. It is possible that the final conditioning and attainment of carrying capacity can be accomplished by using peeler crabs.

To have suitable numbers of bacteria to convert waste materials to less harmful compounds, biological filters must provide suitable substrate upon which the bacteria may grow. A biological filter is nothing more than a box containing materials that provide increased surface area on which bacteria become established. Most any material can be used, such as rocks or shells. The size of the individual pieces of filter material should be such as to provide maximum surface area and permit ample water flow through the filter. It is recommended that individual pieces of the filter medium be no smaller than 1" in diameter.

An additional consideration when choosing filter material is its buffering capabilities. As a result of biological action (crab and bacteria metabolism), there is a tendency for the water within a closed system to become acidic (decrease in pH). Without some method to restore pH to a healthy level, it will continue to decrease ultimately causing crab deaths. The use of materials high in carbonates as filter medium will counteract this acid buildup. These materials are naturally occurring in the form of dolomite gravel (high in magnesium carbonates) and oyster or clam shells (high in calcium carbonates). Limestone, although similar to dolomite, does not have sufficient magnesium concentrations to be an effective buffer.

The Chesapeake Bay filter is called a downflow submerged filter. Water enters from the top, passes through the filter material and is removed (pumped) from the bottom of the filter box. The filter materials are always kept moist or covered with water. While most any kind of box will hold the filter material, the most prevalent type is the bottom half of a concrete septic tank. For a 20 tank shedding system, the bottom half of a 700 to 1000 gallon septic tank is used. To hold down costs, flawed septic tank bottoms that do not meet health department requirements for use in a sanitary system can be utilized. They are available at a reduced price. However, there should be no large leaks in the walls.

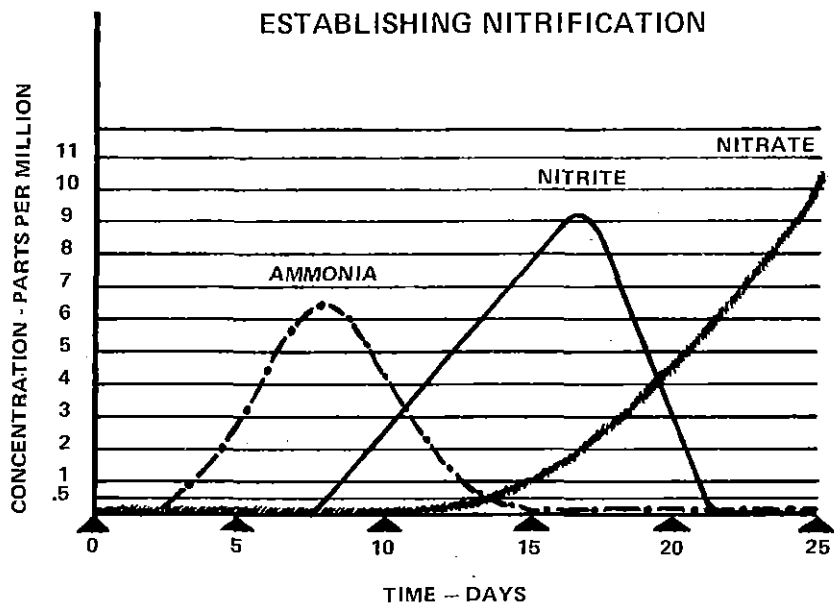

FIGURE 24. Typical conditioning response in a biological filter. Initially, ammonia levels will increase; populations of *Nitrosomonas* bacteria grow and consume ammonia, nitrite concentrations increase; finally, as *Nitrobacter* populations increase, nitrite is converted to less toxic nitrate. The whole process can be viewed as a stepwise procedure occurring over several weeks.

The filter material being used in Chesapeake Bay is mostly oyster shell; however, some clam shell is also used. Oyster shell is readily available at reasonable prices and provides the necessary buffering and surface area requirements for a biological filter. It can be obtained as whole shell or in 1" diameter pieces, or can be easily crushed to make pieces.

Prior to adding shells to the septic tank, a solid partition 6 to 12 inches from an end wall and extending from the top to within a few inches of the bottom is installed inside the tank (Figure 25). This creates a head chamber within the septic tank. Crab pot wire (1" mesh preferable) should be placed at the bottom of the partition to prevent oyster shell from entering the head chamber. Either whole oyster shells or pieces of shell 1" in diameter or larger are put into the larger compartment of the septic tank. Oyster shells to be used should be old, sun-bleached (white) shell, without any pieces of oyster meat or living organisms (mussels, barnacles, worms, etc.) attached. Water is introduced to the filter over the shells and is pumped out from the small head chamber. This forces the water to be drawn down through the oyster shell and pass under the partition prior to being returned to the shedding tanks or sent to another filtering device.

A piece of corrugated fiberglass roofing material with slits evenly cut along all ridges is placed directly over the oyster shells to distribute incoming water evenly over the filter surface (Figure 26). This serves several purposes. First, by spreading the water over the surface of the filter, it helps prevent channelization through the filter material, which would reduce filter efficiency. It can also help reoxygenate water entering the filter through increased agitation and surface disturbance. Other methods can be used to distribute the water over the surface of the filter. These include trough systems with passages in them or spray manifolds.

The final part to a biological filter is a top, and a simple sheet of plywood is sufficient. A top prevents extraneous materials from entering the filter, cuts down on water evaporation, and keeps rain water out.

Additionally, nitrifying bacteria prefer to be in a darkened environment. It also prevents people from accidentally falling into the filter.

The goal of a biological filter is to provide a favorable environment for bacteria to convert all entering toxic nitrogenous waste materials into nitrate. Although nitrate is much less toxic than ammonia or nitrite, given time it may reach dangerous levels. There is another type of bacteria, denitrifying, that attacks nitrate and converts it to free nitrogen gas, which is released to the atmosphere. Unfortunately, unlike nitrifying bacteria, denitrifying bacteria being anaerobic, must work in the absence of oxygen. There are other means of reducing nitrate concentrations, however.

The method being used to reduce nitrate levels in Chesapeake Bay closed systems involves replacing a portion of the water at regular intervals. This reduces ammonia and nitrite levels as well. A good rule of thumb is to replace about a quarter of the volume of water in the entire system with new water every 2 to 3 weeks.

Following biological filtration in importance to a closed system is chemical filtration. Certain chemicals such as proteins, fats and sugars are released in crab feces and urine. These compounds can also be the parent sources for other nitrogenous wastes, thus their removal will benefit the biofilter. They dissolve in water and may build up to critical levels even when a biological filter is in operation. Since these compounds remove oxygen from the water, they compete with crabs for available oxygen. However, not all nitrogenous compounds, such as proteins, are converted to ammonia and then to nitrite and nitrate.

“Chemical filtration” in a shedding system does not necessarily refer to a reaction such as that which occurs between acidic (vinegar) and alkaline (baking soda) compounds. Rather, it refers to a complex process known as adsorption. Adsorption is the concentration or buildup of dissolved substances at a surface or interface. By creating an interface upon which dissolved organic substances can become attached, it is possible to remove them from the system. The interface to be created is between air and water,

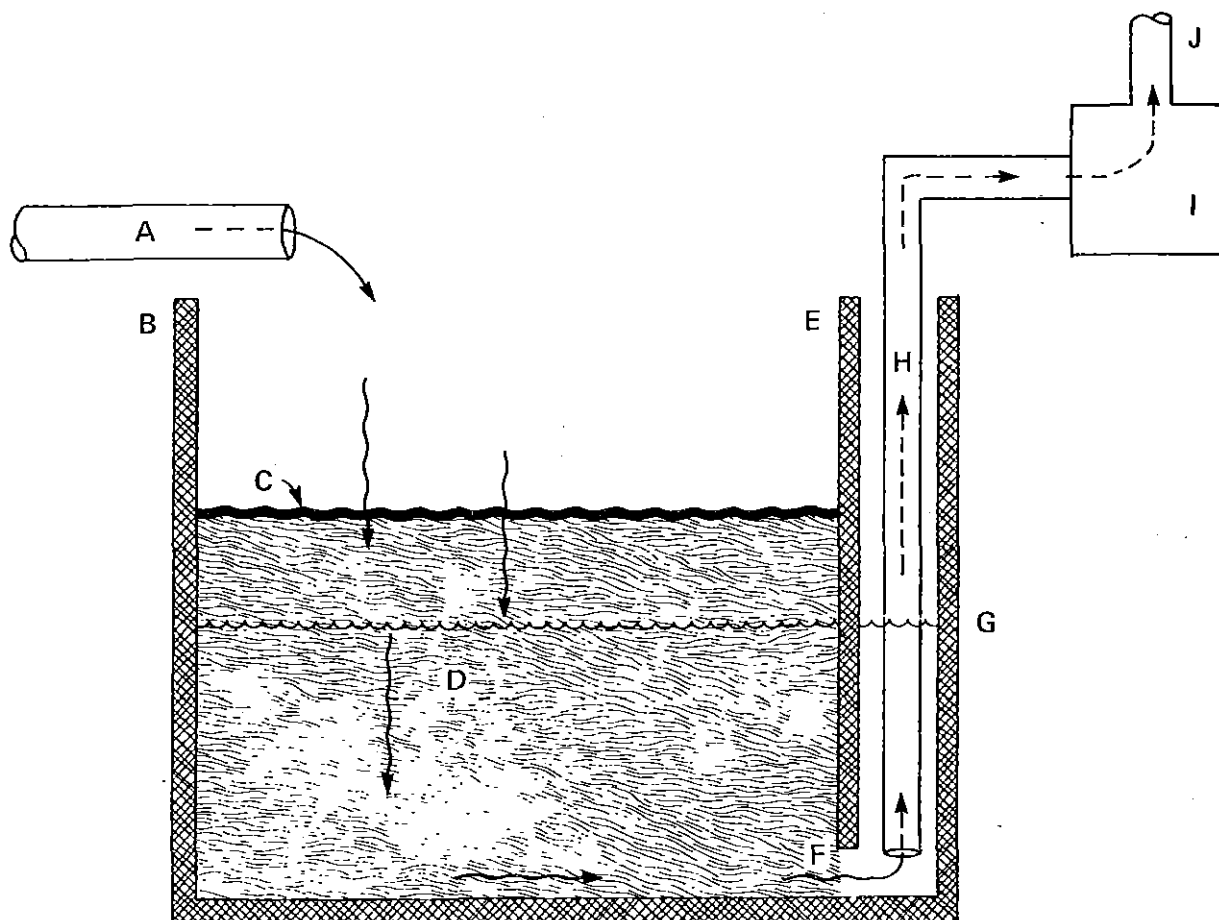

FIGURE 25. Cross section of a biological filter. (A) PVC pipe (4"-6" i.d.) carrying water from the shedding tanks. (B) Bottom half of a septic tank (500-1000 gallon capacity) containing the biological filter. (C) Corrugated fiberglass roofing material with holes (cuts) in it to "spread" water over the filter material. This should be placed directly on top of the filter material. (D) Filter material (sunbleached oyster shells). Oyster shells should fill about 2/3 of the biological filter. In the bottom half of a septic tank this amounts to 30-40 bushels of whole shell. (E) Solid partition within the septic tank creating a head chamber from which water will be pumped. (F) "Open" space (about 2") under dividing partition covered with 1" mesh wire. (G) Water level within biological filter should be maintained, if possible, several inches below the corrugated fiberglass water distribution sheet. (H) Water suction line. (I) Pump. (J) Pipe leading to shedding tanks or protein skimmer. Arrows indicate direction of water flow.

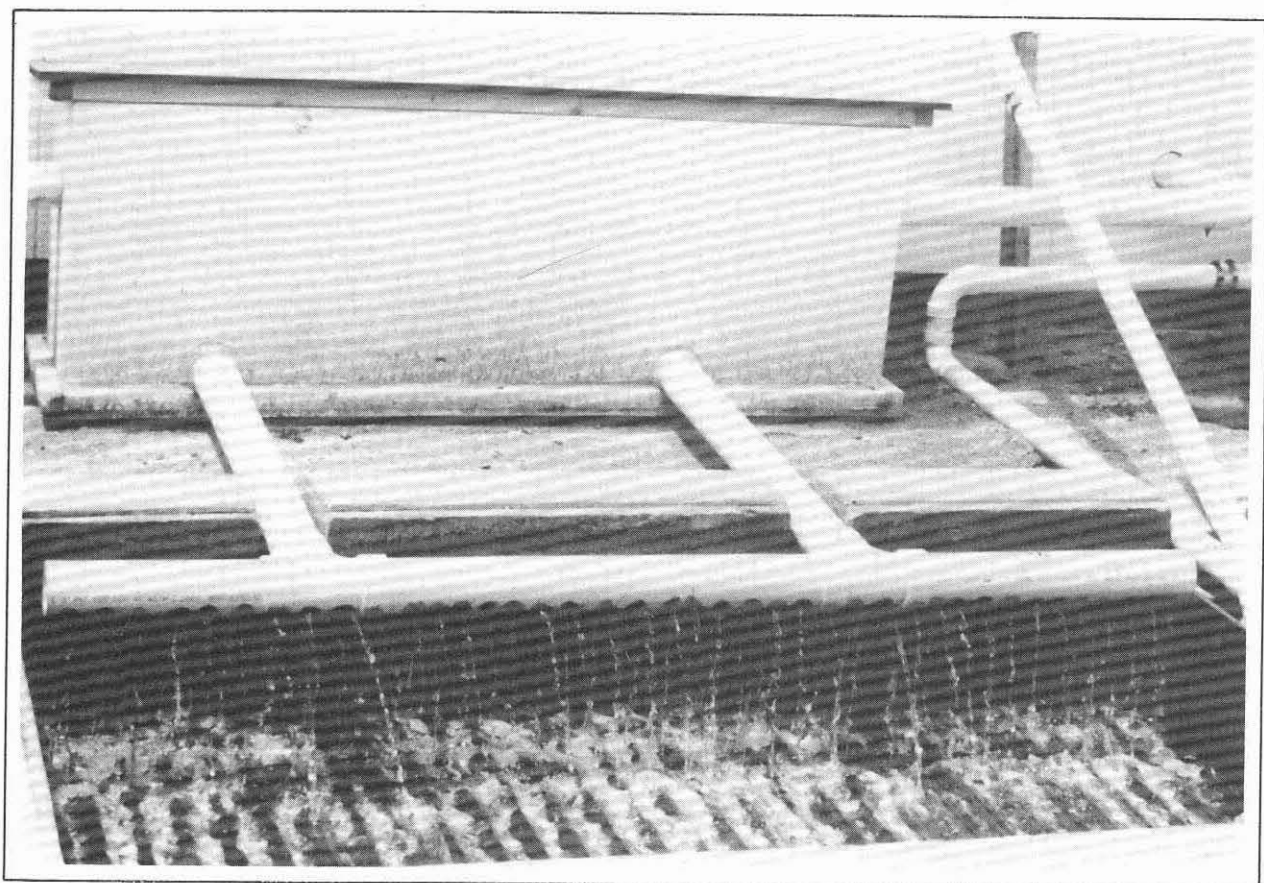

FIGURE 26. Corrugated fiberglass roofing material is used within the biological filter to evenly distribute incoming water over the filter media. The use of a "spray manifold" also increases water distribution, as well as reoxygenation of the water. The white box in this picture contains a mechanical filter to pre-screen water before it enters the biological filter.

bubbles in the water. Bubbles passed through a column of water will accumulate dissolved substances on their surface, resulting in a foam. The foam can be skimmed off the water and discarded. This process is called foam fractionation, airstripping or protein skimming.

Besides benefits derived from direct removal of dissolved organic materials, protein skimmers have additional value. Since much of the organic material being removed is acidic in nature, skimmers are an additional aid in maintaining a stable pH. Also, because of the way skimmers function, they are excellent means of ensuring a well aerated water supply to shedding tanks.

Commercially, skimmers are available in a variety of sizes. They utilize a countercurrent flow of compressed air against water, which creates the foam and causes it to flow to a chamber which can be emptied at periodic intervals. However, this requires that an air compressor be utilized as well as a water circulating pump. Protein skimmers employed by Chesapeake Bay crab shedders use designs which eliminate the need for an outside air compressor and which are easy to construct.

The typical protein skimmer (Figure 27), is constructed entirely of PVC pipe. The main portion of the design is formed by an upright, 15'-20' length of PVC pipe with an internal diameter of 10"-12" (Figure 28). The bottom end of the pipe is capped. This allows the pipe to hold a column of water. Water will enter the skimmer approximately 8"-12" from the bottom and will leave via a pipe inserted through the center of the bottom cap. When the water enters the skimmer there will be a short piece of pipe (Figure 29). A valve in the pipe leaving the skimmer will help regulate the height of water in the skimmer. The height of water within the skimmer should be maintained to within 1-2' of the top. This provides the necessary water column for air to bubble through, as well as creating a head chamber for water flow to the shedding tanks. The easiest method for ascertaining the height of water within the skimmer is to place a float with a stick through it into the skimmer. By knowing the length of the stick and seeing how much is

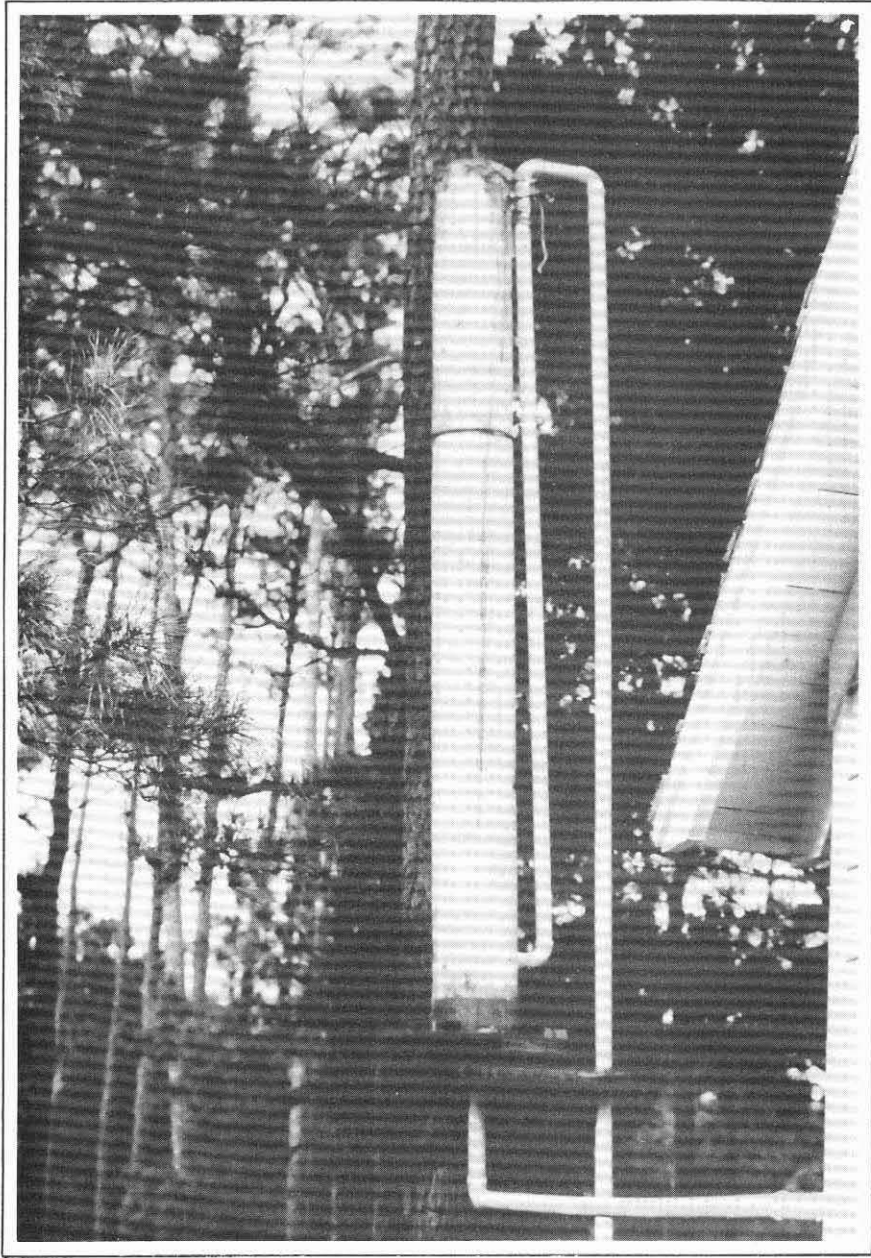

FIGURE 27. Protein skimmer attached to a tree at a Virginia soft crab production facility.

Protein Skimmer

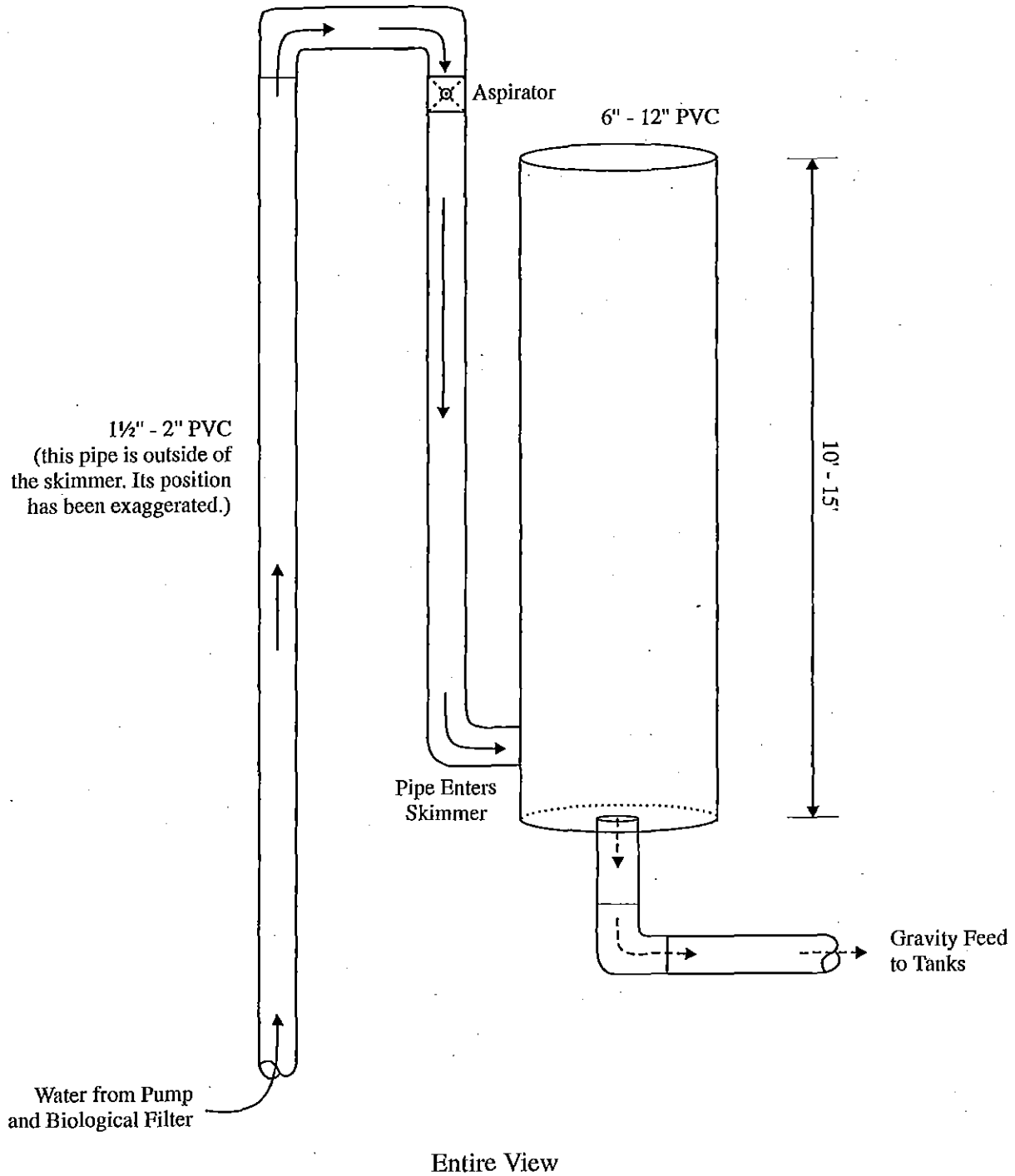

FIGURE 28. Diagrammatic representation of a protein skimmer. This particular skimmer employs an orifice venturi (aspirator) as a means of introducing air into the water column. Dimensions are representative of protein skimmers currently in use. Refer to Figure 29 for cross-sectional view.

PROTEIN SKIMMER

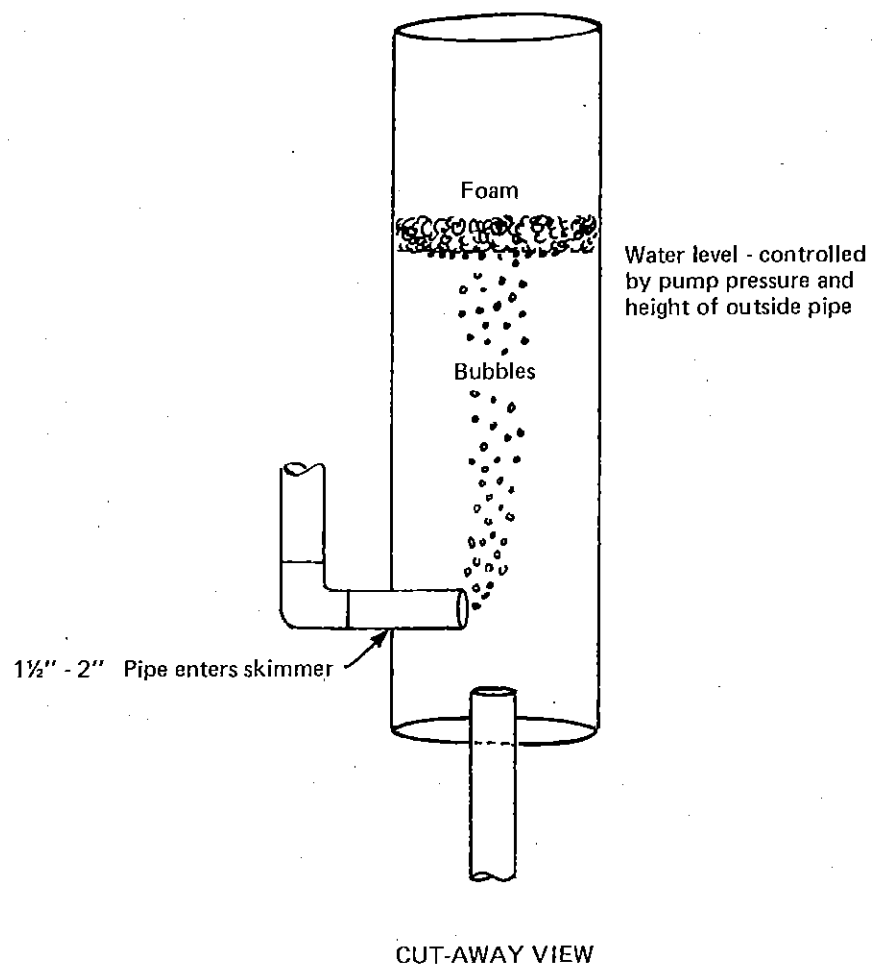

FIGURE 29. Cross-sectional view of a protein skimmer.

above the top of the skimmer, the height of water in the skimmer can be determined.

Chesapeake Bay protein skimmers utilize an orifice venturi to supply the air necessary to create bubbles within the main body of the skimmer. An orifice venturi is nothing more than a constriction or obstruction in a pipe and an adjacent opening to the air. Its placement, however, is critical. Additionally, extra piping is required. However, with the orifice venturi, a pipe must first run up the outside of the main body of the skimmer, make two right angle bends, then run down the outside of the main body before entering the skimmer (Figure 27 and 28). The orifice venturi is placed at the start of the down leg, allowing gravity to aid in water flow and aeration.

Construction of the orifice venturi is a simple task (Figure 30). Prior to connecting the down leg pipe mentioned previously, a hard plastic or metal (non-toxic) disk is inserted. This disk should be of a sufficient diameter to fit tightly into the downward elbow. If this diameter is 2", then a hole with a diameter of 1 1/2" should be drilled into the center of the disk. The disk is then put into the down elbow and the down leg pipe sealed in place. This creates the constriction in the water flow, forcing the water to again jet through the hole. Then about 1/4"-1/2" below the bottom of the down elbow, a 1/8" to 1/4" hole is drilled to allow air to be sucked into the down leg pipe. This hole should either be covered with window screen to prevent insects from plugging it, or should be fitted with a stop-cock valve. The stop-cock valve gives the capability of varying the amount of air that can be sucked in. Observations indicate that the "consistency" of the foam produced can be varied by the amount of air being allowed into the water column.

The final type of filtration, mechanical, is really a strainer to catch large pieces of debris and trap silt before they enter the biological filter. Although to some degree the biological filter acts as a mechanical filter, a separate mechanical filter is included within the Chesapeake Bay closed system.

The most common mechanical filter is nothing more than fiberglass insulation material, held in some manner in the water flow of the system

(Figure 31). Some operators have built frames with pieces of plastic window screen stretched across them and then sandwiched fiberglass insulation between them. Other facilities use plastic milk crates (approximately 1-1/2' x 1-1/2') into which the insulation material is stuffed. Generally, these filters are placed at the point where water enters the biological filter. Then, as the surface of the fiberglass accumulates sediments or other debris, the operator can either peel off a part of the top insulation or just discard the entire fiberglass section and replace it with new clean material.

The typical layout of a closed system which utilizes a septic tank biological filter, a protein skimmer with an orifice venturi and a fiberglass mechanical filter follows (Figure 32). Starting at the shedding tanks, water will flow by gravity toward the biological filter. For this to work the biological filter must be buried with its top at ground level or a few inches above ground level. Putting the biological filter in the ground is also a means of controlling temperature. Prior to entering the biological filter, waste water will pass through the mechanical filter and onto the distribution device (corrugated fiberglass, etc). From the biological filter, water will be pumped (1-1/2 Hp or 2 Hp pump) to the protein skimmer. The protein skimmer must be elevated above the level of the shedding tanks to create a sufficient head pressure to deliver water to the shedding tanks by gravity flow. Generally, the bottom of the skimmer must be raised about 10' above the shedding tanks to accomplish this. Skimmers have been attached to telephone poles, trees and the sides of buildings. From this basic design various modifications can be made.

A possible modification is essentially an expansion of the basic closed system design. One or more biofilter/reservoirs are added to the entire system in such a way that water falls or cascades from one tank to the next. This increases the volume of water which is held within the shedding system. Increasing the biofilter and reservoir holding capacity allows for a greater dilution of nutrients and tends to dampen the effects of shock loading.

ORIFICE VENTURI CONSTRUCTION

This type of construction negates the need for fancy tooling or for an additional compressed air source

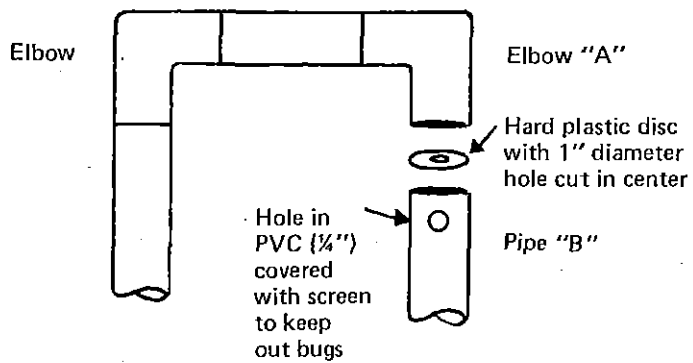

Before connecting Pipe "B" to Elbow "A" insert plastic disc. This creates a constriction, forcing water to "jet" through. This in turn sucks air in through the hole drilled in Pipe "B," oxygenating the water.

FIGURE 30. Construction details for an orifice venturi (aspirator).

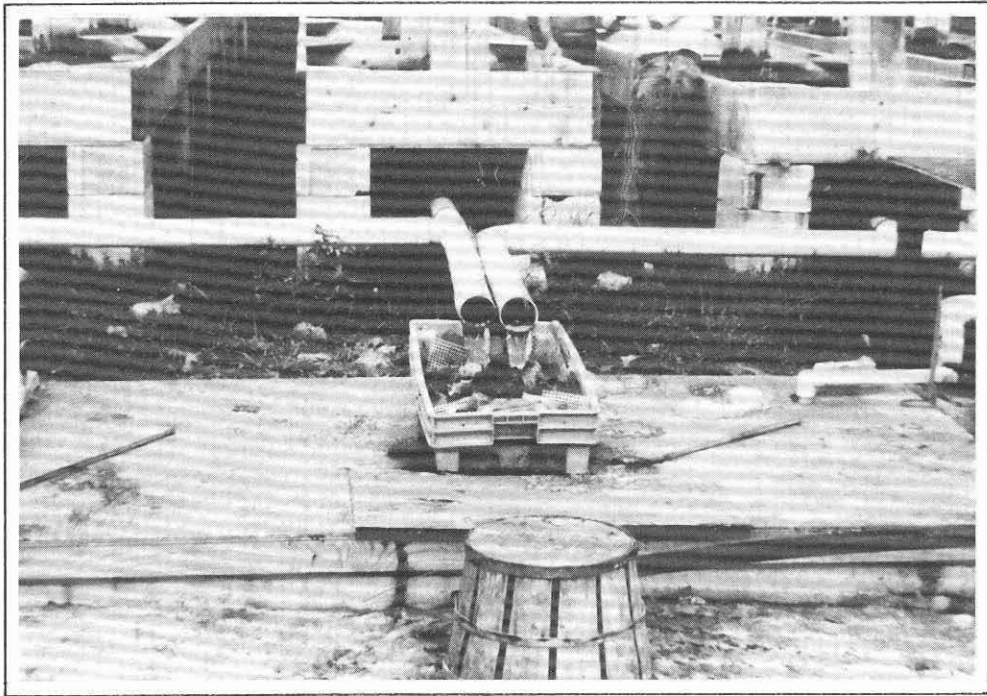

FIGURE 31. A plastic milk crate filled with fiberglass insulation material functioning as a mechanical filter. Its placement between the shedding tanks and biological filter prevents debris from entering the biological filter.

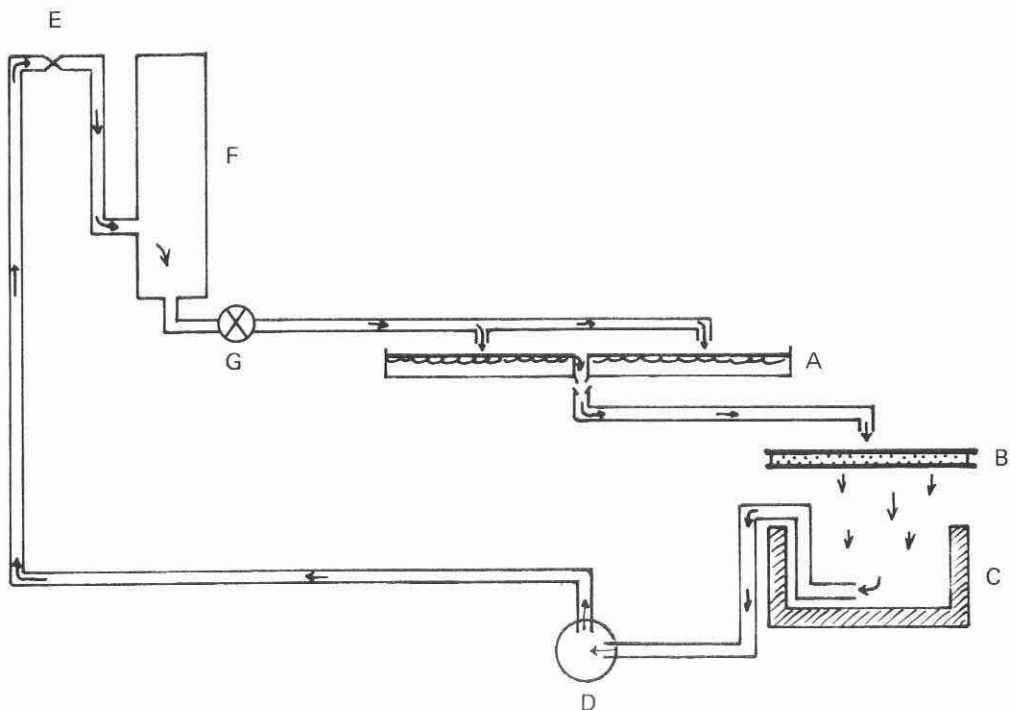

FIGURE 32. Schematic for a closed system utilizing a biological filter, mechanical filter and protein skimmer. (A) Soft crab shedding tank. (B) Mechanical filter. (C) Biological filter. (D) Pump. (E) Throat venturi. (F) Protein skimmer. (G) Valve. Arrows indicate direction of water flow.

A second modification could be called a semi-closed system since the facility functions both in a flow-through and a recirculating mode. This system can be used under special circumstances where the shedding facility is located on a water source of varying quality or availability based on tidal stage. For instance, at high tide there may be adequate depth of good quality water to operate in a flow-through mode. However, at low tide there may be insufficient water of acceptable quality to utilize for flow-through. In a semi-closed system, at high tide, water can be pumped into the shedding system. By incorporating a sump in the system and installing additional valves, the flow-through situation can be quickly and easily converted to a recirculating mode. Since acceptable water quality is available on a regular basis, a total filtration package is not needed. A mechanical filter is added to the sump in order to prevent organic debris from accumulating at the bottom of the sump. As water quality declines over the period of a day or two, the entire water contents in the system can be replaced. This reduces the need for constant and close water monitoring, especially if a regular water replacement schedule is followed. This design is highly site specific, with water quality and quantity available to be able to operate the system in a flow-through mode for at least part of the time.

While there is no longer the problem of positioning intake and outflow, one must still consider the original source of seawater to fill the closed system. There are two options available.

Some operators of a closed system may wish to haul natural seawater to their installation. The feasibility of doing this will depend on the volume of water needed, the distance from the source and the quality of the natural water. One would have to determine the difference in cost between the transportation of natural water (if it is of satisfactory quality) and the use of artificial seawater.

If the shedding facility is located within a short distance of a brackish or marine water supply, it would appear obvious that such a source be utilized. However, it is suggested that the operator determine the quality of the

water before making any decision. Since it is particularly beneficial to have the salinity of the water in a shedding system nearly the same as that from which the crabs were caught, this should be considered when deciding on using a natural water source. The natural water source may not be totally satisfactory, even if the salinity is within the desired range. Suspended sediment may be at a level that would be detrimental to the facility in the form of shutdown time for such tasks as cleaning tanks, unclogging pipes or repairing pumps. The natural water supply may contain undesirable concentrations of phosphates, nitrates, pesticides, heavy metals and other forms of pollution. Rather than operating with water of low quality, one might consider transporting water from another source or making artificial seawater.

Artificial sea salts are available commercially. They are convenient in that one can concoct any salinity desired. Common table salt or commercial rock salt are not satisfactory for use in making artificial seawater. Sea salts contain the major chemical elements and most of the minor elements in the same proportions as in natural water. The salt mixtures are designed to be made up with fresh water. Some brands condone the use of tap water; others specify that deionized or distilled water be used, making them very expensive for use in a crab shedding facility. Regardless of the brand of artificial salt used, it is necessary to know the quality of the freshwater supply. If chlorinated tap water is to be used, the chlorine in it should be removed by allowing the water to stand for several days and by bubbling air through it. Most operators choose to haul natural seawater because of the expense involved in using artificial salts. Additionally, problems could arise if the operator is forced to change water quickly.

In any recirculating system, certain water quality tests must be made on a routine basis. All of the tests mentioned below should be performed weekly or more frequently. There are water chemistry kits or instruments on the market (pet stores, etc.) which allow such analyses to be performed simply and conveniently. In recirculated systems the recommended analy-

ses should include: ammonia (danger level above 4 ppm); nitrite (danger level above 1 ppm); nitrate (danger level unknown, but thought to be hundreds of ppm); dissolved oxygen (danger level below 3.0 ppm); pH (danger level any deviation below 7.0 and above 8.0); and salinity. It is important that a record be kept of all water quality measures. In this way, potential problems can be identified and dealt with before they arise.

Salinity is the only parameter which cannot be measured with a water chemistry kit. It is easily estimated by measuring the specific gravity (density) of the water with an hydrometer available from most aquarium supply houses or pet stores. It would be better, however, to pay a little more and buy a direct-reading hydrometer (which shows salinity) with an expanded scale. Because the water in a closed system will evaporate, leaving the salts behind, salinity will have a tendency to rise. When water is first added, establish a baseline value for salinity, then as it rises add fresh water to return it to the original level.

A few words of caution prior to investing in a closed system. Recirculating systems are not for everybody. If good quality water is available at your location, an open, flow-through system may be superior to a closed system. At least an open system should be your initial shedding facility. If problems are experienced, then consider a closed system. Closed systems will not prevent all mortalities. Only those deaths due to poor water quality can be avoided. Mortalities for any other reason (poor quality peelers, etc.) will still occur. Do not build a closed system just because it has worked well for someone else. Consider all the variables already mentioned and evaluate your own situation. Experience has shown that closed systems are not good for the holding of green peelers (early white line) and the subsequent ripening to rank peelers (pink-red line). Lastly, closed system shedding is still relatively new, with developments in information and filtration happening around the country. Be prepared and willing to change; seek out other information from different sources.

Facility Operations

Topics dealing with day to day operations of a shedding facility range from considerations of handling, culling and harvesting, to water quality, and will apply to float and shore-based operations.

To a great extent, success in shedding soft crabs will depend upon the original condition, sex and sign of peelers placed in the system. Already discussed were the types of gear and their effects on peeler quality. Peelers with injuries such as puncture wounds run a high risk of not completing a shed. "Nicking" by breaking the movable finger on a crab's claw is a common practice within the industry but it is **not** recommended. It is done to prevent cannibalism and fighting, primarily among green peelers; rank peelers, being closer to shedding, normally are not nicked.

Improper nicking can cause bleeding, swelling and blood clot formation in the joint which may lead to infection and death. Also, swelling may prevent successful claw extraction, causing the crab to "hang-up" and die, or shed without claws. A clawless soft crab is called a "buffalo." Proper separation of peelers of different signs and good handling practices, along with a properly functioning float or tank, should be sufficient to keep fighting and cannibalism to a minimum.

The sign of a peeler has much to do with success in shedding. The following table illustrates the results of a study conducted in Crisfield, Maryland on shedding success of different sign peelers held in floats:

SIGN	% SHED	TIME TO SHED
Red (Rank)	91.2	1 - 3 days
Pink	83.5	2 - 5 days
White	59.2	3 - 10 days
Green (Hard)	47.5	5 - 25 days

Peelers of different stages of ripeness should never be mixed in one tank; each stage should be isolated in its own tank. Those that are rank (red sign) should not be handled again until they are soft crabs. Ideally, one would want to hold only rank crabs; during major run periods (spring and late summer in Virginia) this may be possible. However, at other times it is necessary to hold white sign crabs. Tanks in which white sign crabs were originally placed must be culled through every 3-4 days to remove peelers that have advanced to the next stage. If not, the possibility exists of white crabs cannibalizing rank peelers or busters. However, after the second culling (6-8 days), remaining white sign crabs should either be sold as fishing bait or discarded because of the greater risk of mortalities associated with injuries or physical weakness. It becomes uneconomical to hold white sign peelers beyond the second culling.

Among established soft crab producers there is an overwhelming opinion that female crabs shed better (more successfully) than male crabs. Major run periods consist largely of female crabs approaching maturity. These crabs seem to be hardier than male crabs at other times. Also, male white sign peelers may delay their shedding when in the presence of rank females. It may be advisable to segregate male peelers from female peelers.

When adding or culling crabs from floats/tanks, care should be exercised in handling. Peelers should not be thrown or dumped in large masses into a float/tank, but should be released slowly, and spread throughout the tank. Any unnecessary agitation should be avoided. During the main part of the shedding season, good success in shedding can be obtained if no more than 200 to 300 peelers are held per 4' x 8' tank with 4" of water. For the "first run," however, because of lower water temperatures, up to 600 crabs, depending on size, can generally be held in a 4' x 8' tank with good success in shedding. Overcrowding during other periods may lead to increased physical injuries to the crabs and oxygen deficiencies.

At regular intervals during the day it is necessary to check floats/tanks holding rank peelers for soft crabs. This is termed a "fish-up," "dip-up" or

simply "fishing." The timing, described later, is critical; if the soft crab is left in the water too long its shell will begin to harden, producing an inferior product. When the crab is removed from the water, the hardening process of the new shell ceases. It is necessary, however, that a soft crab be allowed to expand to its full size, especially if it is to be marketed alive.

Several criteria are used to determine if the right degree of "hardness" has been obtained and if the soft crab should be removed from the water. Immediately after emerging from the shed, the soft crab will have a soft and pliable top, with a wrinkled area in front of the backfin. On a fully expanded crab there will be no wrinkles in the backfin area, but a slight bulging that is springy to the touch. A crab that will not be able to hold its claws next to its body, that is, its claws will "dangle", has not hardened sufficiently to withstand the rigors of live shipment. A third characteristic is that the large lateral spines have begun to feel sharp to the touch, but the entire spine is still pliable. Finally, the top and bottom shells must be firm, but not as firm as stiff writing paper. These last two methods of determining hardness are skills learned through experience.

Several factors, mainly temperature and salinity of the water, combine to determine how quickly a soft crab will expand to full-size or harden. Generally, as water temperature increases, hardening and expansion time becomes shorter. Also, crabs harden faster in lower salinities than in higher salinities. Because of these factors, 15 minutes to several hours may elapse before the soft crab is fully expanded.

For these reasons, the length of time between fish-ups will also vary. An additional factor in determining time between fish-ups is how particular and concerned the crab shedder is about producing a quality soft crab. Most soft crab producers will do complete fish-ups every 4-6 hours and may make spot checks between regularly scheduled fishings. There is still a risk of soft crabs becoming too hard (paper-shelled) with this frequency of fish-ups. Of the regularly scheduled fish-ups, at least one should be before dawn, since shedding activity is greatest at night.

There is no one salinity best for shedding blue crabs. Although blue crabs can tolerate wide salinity ranges, they acclimate to change slowly. Large, abrupt salinity fluctuations cause stress or direct mortality of peelers, with busters and rank peelers being especially vulnerable to salinity changes. For this reason, peelers should be harvested from waters of approximately the same salinity as the location of your shedding facility. This may not always be possible; however, salinity where peelers are caught should be no more than 5 parts per thousand higher or lower than the salinity of the shedding facility water.

The molting of blue crabs is regulated by water temperature. A certain threshold or minimum water temperature must be reached before blue crabs begin to molt. Water temperature near 70°F (21°C) is required for active shedding, although crabs begin shedding at temperatures in the mid-60's (18-19°C). But water temperature can get much higher than optimum during the shedding season. When water temperature approaches 80-85°F (26.5-29.5°C), respiration problems can develop for peelers and mortality can occur. High water temperatures are linked to oxygen stress.

Several strategies should be considered to help maintain the lowest possible water temperature that is favorable to shedding within the shedding system. The simplest is to shade tanks from direct sunlight. Not only will this help keep temperatures down, but it will also reduce algal growth. As previously mentioned, drawing intake water from deeper water layers will bring in cooler water.

Other means of cooling water have been suggested but have not been tested in Virginia. A saltwater well may provide a lower and more constant water temperature. Likewise, supplemental cooling using refrigeration units, or heat exchanging by running water pipes through cold rooms or freezers may be considered. However, adding ice to the system to lower temperatures is definitely not recommended.

Recirculating systems have another temperature problem in the early part of the season. Because they are most often shaded, the water enclosed

systems are slower to warm in the springtime. This means that crabs may take longer to molt in a closed system. To counteract this, closed system operators should heat their water for the early part of the season by using immersion heaters, heat exchangers or other methods.

Maintaining a high oxygen level for blue crabs is extremely important. After poor physical condition of peelers, the second greatest cause of mortality within a shedding system is oxygen deficiency. In actuality this may be a combination of high water temperature and low dissolved oxygen. As water temperature and salinity increase, the amount of oxygen that can be carried by the water will decrease. Cold, fresh water contains the largest amount of oxygen per unit volume of water.

The active blue crab must have moderate or high concentrations of dissolved oxygen available. Oxygen levels above 2.5 parts per million (ppm) are critical to survival, since the blue crab is unable to adjust its breathing rate below this point. In order to better understand how reduced oxygen can cause deaths, an explanation of oxygen consumption patterns of shedding crabs follows.

Throughout the hard and peeler stages and until the crab begins to molt, a crab will need oxygen. As the crab begins to shed, oxygen consumption decreases or actually ceases. This is due to the gills ("dead men") and gill bailer (a structure that circulates water over the gills) not functioning because they are losing their hard outer covers or are already soft. At this point the crab is relying on stored oxygen, and is building up an oxygen "debt" that must be repaid quickly following molting.

After the molt, as structures begin to harden, oxygen consumption will rise quickly, sometimes to a level above the original starting point. If the crab starts to molt while in a stressed state due to reduced oxygen levels in the water or without a sufficient "stockpile" of oxygen within its body, it may not have enough oxygen to carry it through the shed. It could hang up part way through the shed and die. Likewise, after the shed, if the water has a low dissolved oxygen content, the crab may not be able to repay its

oxygen debt and could die. Compounding all of this is the fact that as temperatures increase, the metabolism of the crab increases, requiring more oxygen for survival.

It is for these reasons that oxygen levels should be maintained as high as possible within shedding tanks. If water is deficient in oxygen, supplemental aeration using compressed air will not significantly increase the amount of oxygen dissolved in the water. There are, however, other strategies that can help alleviate oxygen problems. Already covered was the means of water introduction to the shedding tank as a way of ensuring good aeration. The use of aspirators, or a heavy splash or spray at the surface, will help ensure that the oxygen level is at saturation. Additionally, maintenance of good water circulation will help assure the uniform distribution of oxygen. Reducing the water temperature will increase the amount of oxygen that can be carried within the water. Finally, on hotter days, the number of crabs held per tank should be reduced. A reduction in the number of crabs will mean that each crab will have a greater share of the available oxygen.

It is advisable to maintain the shedding system, tanks and surrounding grounds in as clean a condition as possible. Floats/tanks should be cleaned frequently to remove mud, excreta, lost appendages, empty sheds and dead crabs. Accumulations of these materials consume oxygen and can open the way for bacteria or disease infestations. Similarly, good management and maintenance of the grounds surrounding your shedding facility will help keep down nuisance pests. It is a good practice not to use any type of poison or insect repellent around the shedding tanks or near the water source.

Frequent questions asked by newcomers to the soft crab industry deal with how natural phenomena affect soft crab production. The most common question has to do with moon stage. The most prevalent opinion held by members of the soft crab industry is that the full moon exerts the greatest effect on crab shedding. They see the greatest activity in molting for several

days before and after a full moon. Although there is no scientific data to support this idea, it is universally accepted by soft crab producers.

Certain weather events also are credited by industry members with affecting shedding. An approaching summer storm with thunder and lightning has been said to speed up shedding. In the early part of the season (May), a northeaster is said to cause peelers in tanks to ball-up or cling to each other, resulting in increased injuries and mortalities.

Rainfall is said to do several different things. One is that by reducing salinity of the water supply, it causes crabs to harden much faster. Secondly, because of turbulence and the stirring up of sediments and silt in rivers and creeks, the crab's gills become fouled and gas exchange (breathing) at the surface of the gills is reduced. When such crabs are brought to the shedding tanks, they show increased mortality rates. Lastly, the runoff from adjacent land carries sediments which adsorb pesticides or other pollutants that may be toxic to peelers.

Most soft crab producers will provide several forms of special care to individual crabs. One of these is to cause peelers to cast off (autotomize) damaged appendages. Crustaceans have the unique ability to voluntarily cast off a leg at a pre-determined fracture line which is located near the base of the leg. This permits them to escape predators that have grabbed a leg or to discard injured legs. The best way to remove an injured leg is to grasp the long section of leg nearest to the body with one hand and twist the last couple sections to stimulate the autotomizing reflex. Little damage is done to the crab and it can molt normally, whereas with an injured leg, it may hang up in the shell and die.

Some soft crab producers will manually extract a crab from its shell if it becomes hung-up while shedding. This is done by carefully breaking off pieces of the old shell or by gently pulling on the soft crab and old shell simultaneously. Associated with this is a form of artificial respiration or a "heart massage" given to the crab. Sometimes this can be used to revive crabs that have just "died" during the shed. The crab's heart is directly un-

der its top shell to the rear of center of its body (watch a live soft crab closely and you can see the heart beating). A gentle pumping action with a finger will sometimes revive the crab.

Marketing and Packaging

The demand for soft crabs has consistently exceeded the supply. For this reason, soft crabs are reasonably easy to sell. The only question is for how much they can be sold. Prices received for soft crabs will depend upon the quality and size of the crab, season and availability. Top quality soft crabs, with all their appendages and the proper degree of softness (no paper shells), will bring a better price than those of inferior quality, regardless of how they are marketed.

Soft crabs, unlike many seafood products, are sold by the dozen rather than weight, and are graded by size. Trade names are given to the size designations: crabs measuring 3.5 to 4.0 inches across the back from point to point are called "mediums"; crabs 4.0 to 4.5 inches are "hotels"; crabs 4.5 to 5.0 inches are "primes"; crabs 5.0 to 5.5 inches are "jumbos" or "large"; and any crabs over 5.5 inches are "whales" or "slabs." Some producers choose to combine hotel and prime sized crabs into one grade, usually identified as primes. Larger sized soft crabs will bring a higher price throughout the year.

While soft crabs have been traditionally sold by size, there has been increasing interest in marketing them by weight class. One such scheme already in use for live soft crabs follows: mediums, 1.2-1.9 ounces; hotels, 1.9-2.6 ounces; primes, 2.6-3.0 ounces; jumbos, 3.9-5.3 ounces; and, whales, over 5.3 ounces.

Traditionally, prices on all sizes of fresh, live crabs will be higher at the beginning of the shedding season; as the season progresses and the availability of crabs increases, prices will drop. This seasonality of pricing has led many producers to market their product in both the fresh and frozen state, taking advantage of the best price periods for each.

When selling soft crabs there are several options to consider. The main question a soft crab producer needs to ask himself is, "How do I want to sell my crabs?" The first option to consider, and the easiest to resolve, is to sell to a seafood wholesaler in the region. These firms usually are well established or their reputations are known in the immediate area. In many cases they will come to your shedding facility to pick up the crabs. Additionally, when dealing with local wholesalers, soft crab producers will receive an agreed upon price for their product. Firms that deal exclusively in soft crabs are also active in the Chesapeake Bay region. They generally will pay a fair price for your product, albeit a bit lower than what you might get elsewhere. For an individual just starting in the crab-shedding business, the convenience of this type of marketing is attractive.

Soft crabs can also be sold through brokers on a commission (consignment) basis. These transactions usually are with seafood dealers at the major seafood distribution centers in New York (Fulton Fish Market), Baltimore, Philadelphia, or Washington, D.C. Sales agreements generally are consummated over the telephone. Once such sales contacts are established, it is not unusual for soft crab producers to get regular phone calls quoting a price to be paid and an order placed. In many cases, however, soft crab producers that sell on consignment may not know the price they are to receive until after the crabs are shipped and sold. An additional question in consignment sales is "Who pays the freight?" Usually it is the producer. If the buyer wants the crabs badly enough, he might offer to pay transportation. Prices received from consignment sales may fluctuate widely over a relatively short period.

An outlet that should not be overlooked is the local market for soft crabs. This direct marketing approach, while being the most time consuming, may offer the best dollar return to the crab shedder. Local seafood retail outlets and seafood restaurants should be viewed as potential customers.

Direct consumer sales are also a possibility. An innovative soft crab producer can use all sorts of gimmicks to sell his product directly to the consumer. In one instance a firm erected signs on a main highway announcing "crab ranch-come watch our crabs shed," with arrows and directions to their facility. When inquisitive people showed up, they were courteously greeted, given a quick tour and explanation of the facility, and then sold some soft crabs at a retail price. Other forms of advertising can also bring consumers out searching for a bargain or a superior product directly from the producer.

Regardless of the method chosen to sell your product, there is one rule always to follow-look out for yourself! Know the terms of any sales agreement; who is expected to pay for what; how payment is to be made and when; provisions for quality; who provides shipping containers; etc., etc. Besides being a soft crab producer, it's important to remember that you are also a businessman. It may even be to your advantage to take a course in business or sales management from a local community college or vo-tech center, or at least, to do some independent reading and studying.

Originally, soft crabs were marketed alive as a fresh product. Today they are sold both as a fresh product and frozen. The previously mentioned marketing strategies apply to both. However, each market form has unique sales or packaging features.

Fresh, live soft crabs are an important commodity. The concept of quality associated with freshness, plus the higher prices live products bring, continues to make the sale of live soft crabs significant. In most years, however, the best profit from the sale of live soft crabs on the open market is realized during the early part of the season. This is at a time when frozen soft crab inventory from the previous year is at its lowest, all producers are



FIGURE 33. Waxed cardboard soft crab shipping box.

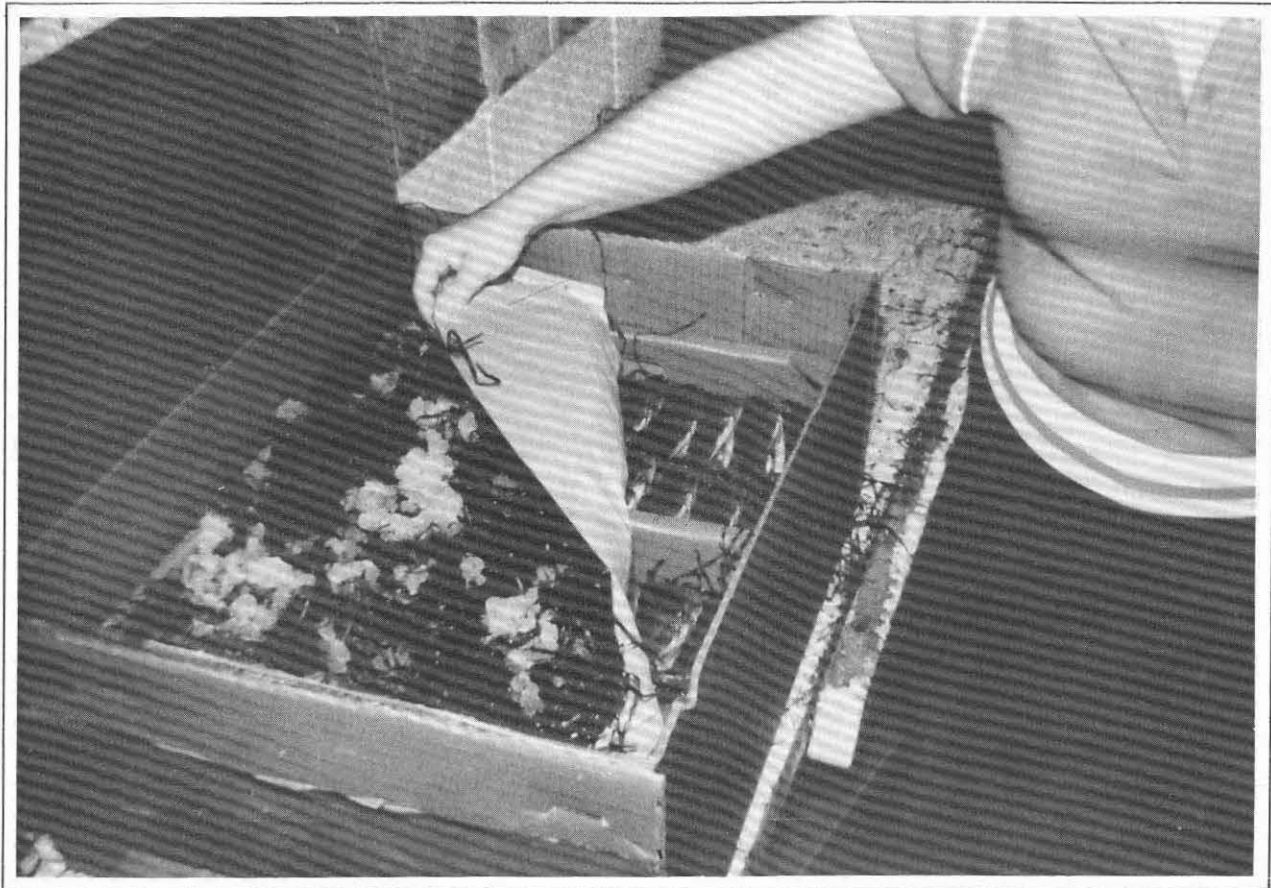

FIGURE 34. Live soft crabs packed in a shipping box. Note the layer of grass and ice overlaying a piece of parchment paper.

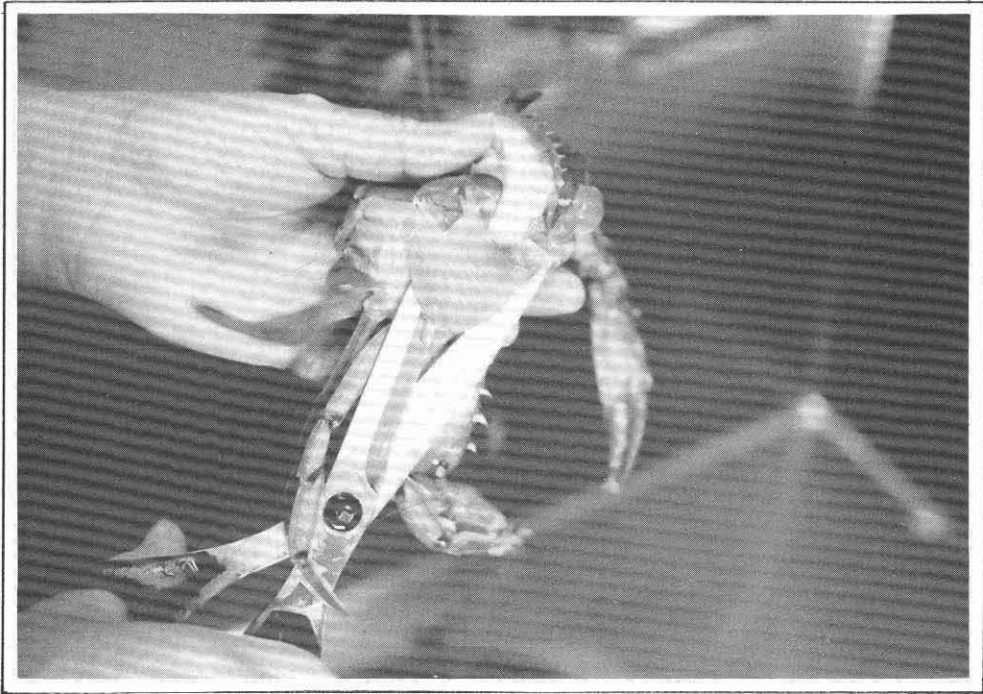

FIGURE 35. Removing the gills of a soft crab during the cleaning process. The large lateral spines are lifted, exposing the feathery gills, which are removed with stainless steel scissors or a knife.

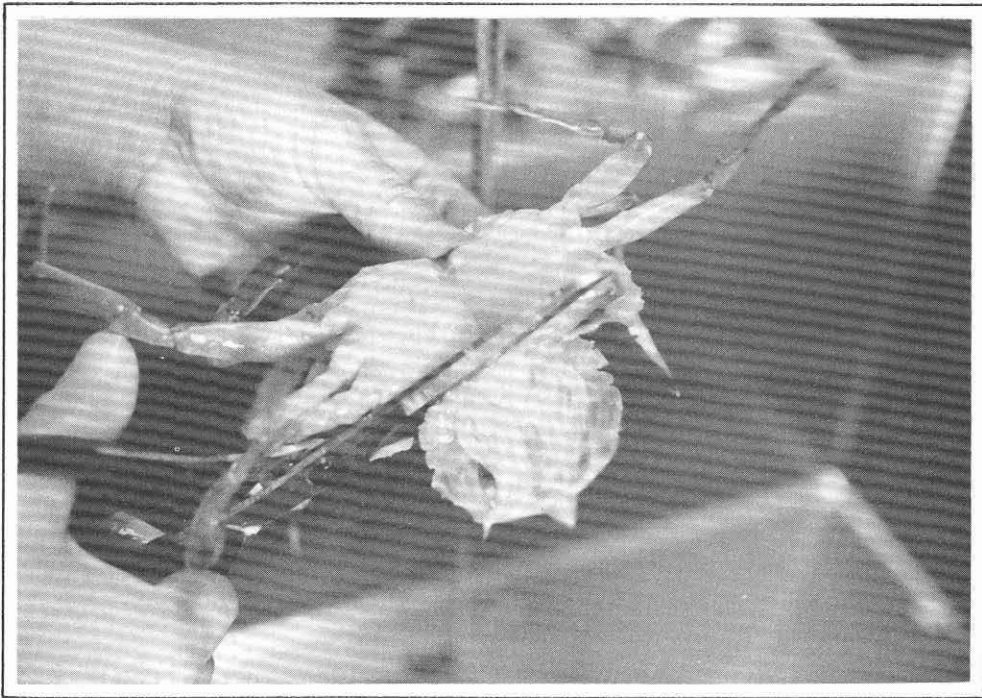

FIGURE 36. Removing the abdomen (apron) of a soft crab during the cleaning process.

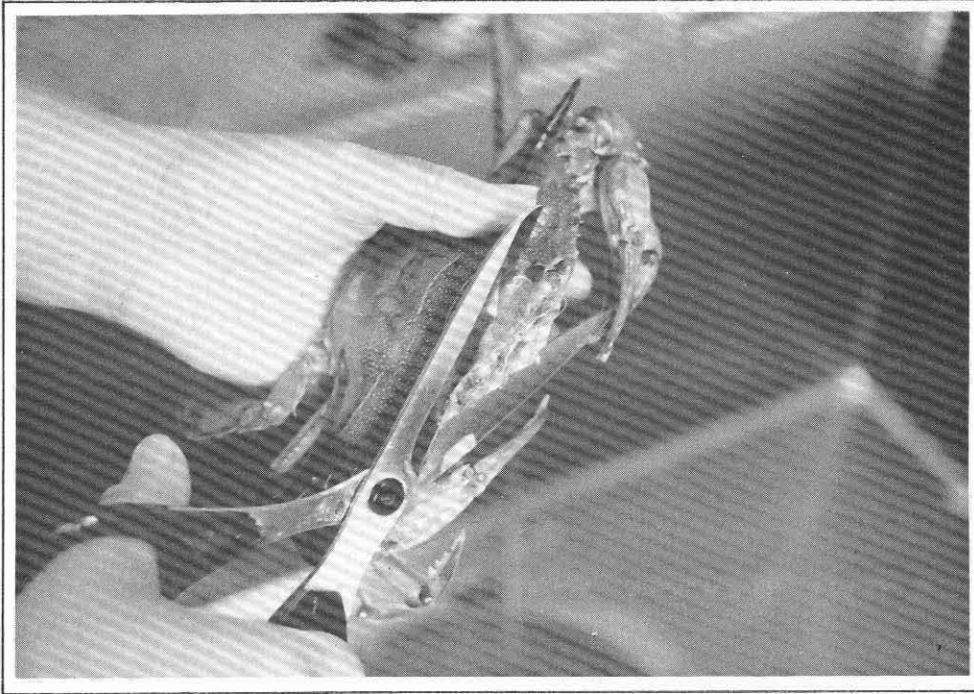

FIGURE 37. Removing the eyes and scaly mouth parts during the cleaning process. An angled cut is made from just behind the eyes to below the mouth parts.

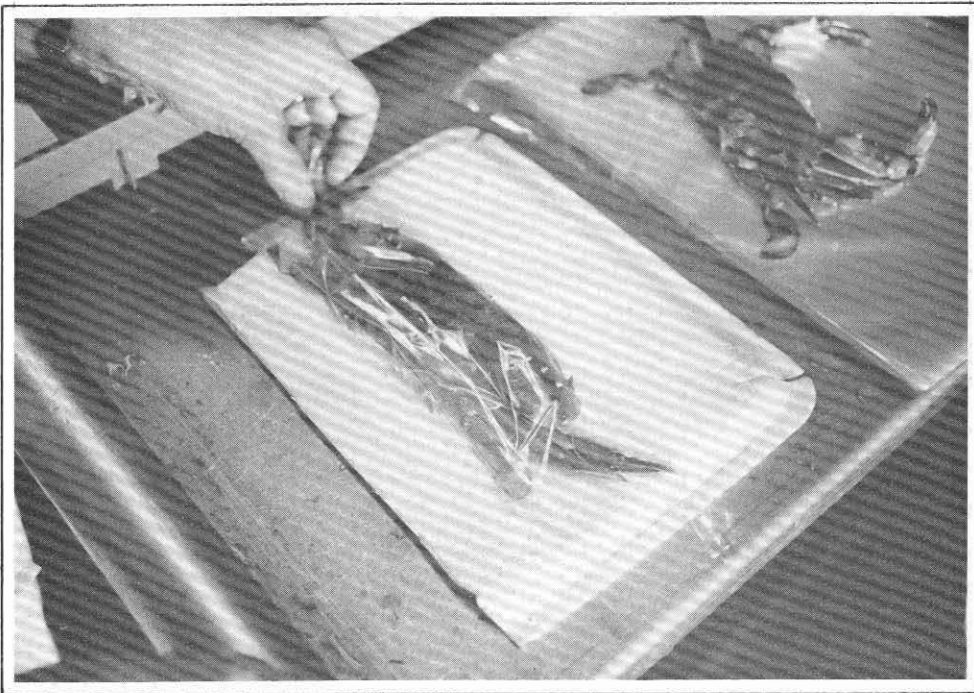

FIGURE 38. A cleaned soft crab in the first step of wrapping, prior to freezing. The crab is neatly placed belly-down in the center of a piece of cellophane; the cellophane is lifted over the back and tucked tightly under the crab; the cellophane ends are folded over the back to complete the wrap.

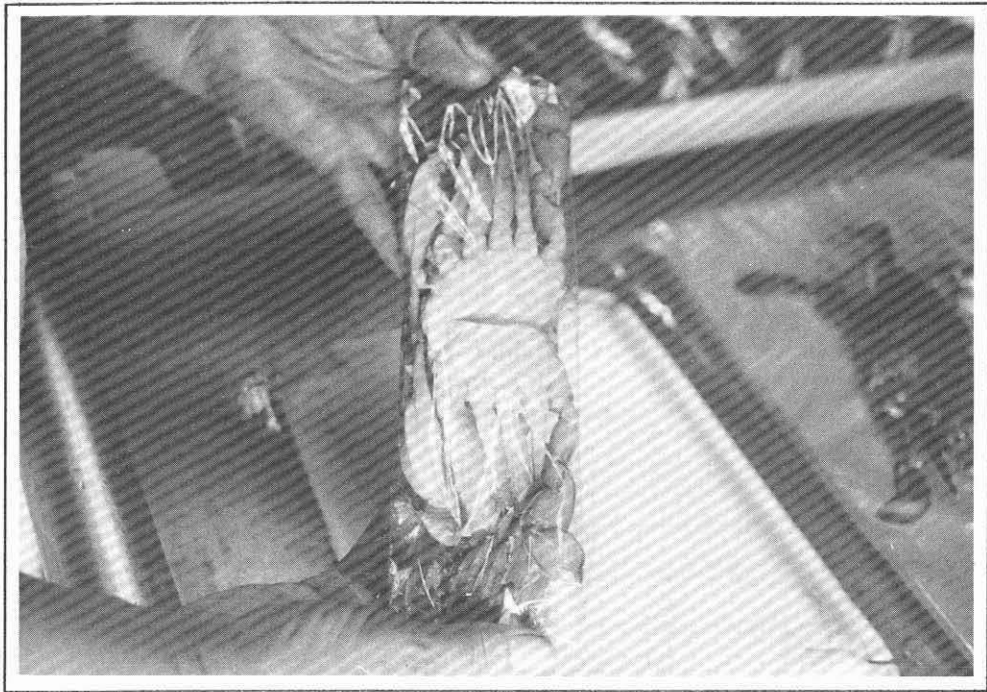

FIGURE 39. A wrapped crab, showing the crab's underside.

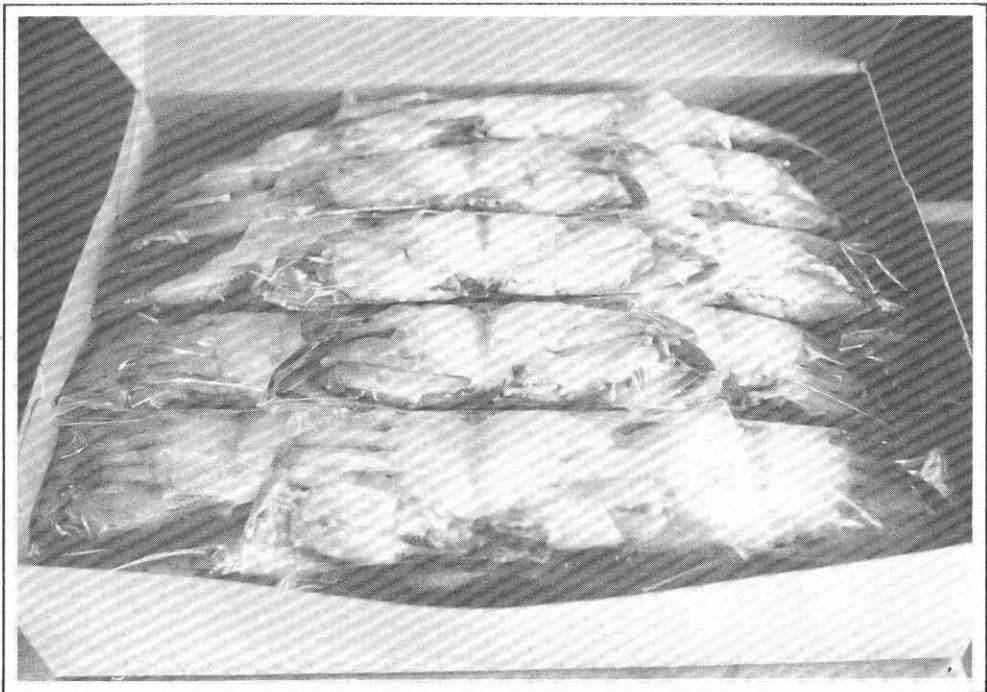

FIGURE 40. Individually wrapped soft crabs packed for freezing. Crabs are packed belly-up with the face and claws raised at a slight angle. This allows the color of the claws to be seen.

not at full capacity, and demand is growing as consumers begin to think more of soft crabs. It is also during a time when soft crabs survive shipment better because of cooler weather. As the soft crab season approaches an end (September -October), and the availability of fresh soft crabs decreases, there may be an increase in prices paid for live soft crabs.

Many Virginia producers who deal in live soft crabs will begin to cut back on their sale of fresh product after the beginning of July. This is due to the increased competition from other producing areas, primarily Maryland. At this time producers will begin to freeze more, laying away an inventory for slack production periods.

Soft crabs to be shipped alive should be permitted to harden for a slightly longer time than normal; this enables them to more easily withstand the rigors of shipment. It also allows the crabs to be stored longer, facilitating more economical shipping of larger quantities. Live soft crabs that have not been abused during handling will survive 4-5 days at storage temperatures of 48-50°F (9.0-10°C).

Just as there are fish shipping boxes, there are also specially made soft crab shipping boxes (Figure 33). These boxes measure approximately 23" x 18" x 10". They were formerly wooden crates but now are corrugated cardboard, wax-dipped for water resistance, and of 250 lb. test strength. Inside a typical soft crab box are usually three nesting trays. For packing fresh crabs, a parchment or wet strength paper is also used (approximately 16" x 21" to cover trays).

Live soft crabs must be packed carefully in the trays of the aforementioned soft crab shipping boxes if they are to arrive at their destination alive (Figure 34). A layer of eel grass (*Zostera marina*) or short-stemmed barley straw packing is spread on the bottom of each tray. The crabs are placed belly (apron) down directly on the packing, all facing in the same direction. Each crab will be angled upward slightly, resting partially on the crab in front of it. This upward angling helps retain moisture in the crab's gill cavity for respiration. A piece of parchment or wet strength paper is placed on

top of the crabs. Another, thinner layer of grass or straw covers the paper, and flake ice is sprinkled on top of the paper. This is done for each of the three trays in a box—grass, crabs, paper, grass, ice. A single tray can hold 5 (or more) dozen mediums, 5 dozen hotels, 4 dozen primes, 3 dozen jumbos, or 2 dozen whales. It may be necessary to angle the larger grades to fit them into the trays. After all three trays have been packed, the lid should be put on the box and the entire package handled gently during storage and shipment. Care should be taken not to expose live soft crabs to truck exhaust fumes during shipment as these will kill soft crabs.

Freezing of soft crabs offers a means of extending sales over a longer period of time. It allows producers to take advantage of higher prices for soft crabs during periods of reduced availability. Freezing also allows larger producers to store crabs they were unable to sell on the fresh market. Frozen crabs also have an advantage when it comes to shipping due to their ease of handling. Recently there has even been interest in the export of frozen soft crabs to overseas markets.

Frozen crabs are packed into a standard 3" x 9" x 12" box, double waxed on both sides. Additionally, frozen soft crabs are wrapped in cellophane. The size of this wrapper will be determined by the size of soft crab, but generally a 9" x 12" piece will handle almost any size. This cellophane should be 250 gauge, saran coated if possible. One of the major suppliers of paper products to the seafood industry is Southland Container Incorporated (8620 Dorsey Run Road, Jessup, Maryland 20794, 1-800-888-5824). This is by no means the only source of these paper products. The prudent buyer will shop around and search out other suppliers for comparison buying.

Crabs that are to be frozen can be either cleaned ("dressed") or uncleaned, determined by buyer preference. Buyers that prefer uncleaned frozen crabs state that they obtain a more juicy, plumper product than when the crabs are cleaned. Both cleaned and uncleaned soft crabs are individually wrapped in cellophane prior to freezing.

Cleaning soft crabs is a fast, easy procedure that can be learned quickly by most people. The large lateral spines of the shell top are lifted and the underlying gills (feathery structures) cut off using sharp stainless steel scissors or knives (Figure 35). Scissors are easier to handle and speed up the operation. The apron (abdomen) is then removed (Figure 36). Next the eyes and scaly mouthparts are removed prior to wrapping (Figure 37). Cleaned crabs which are not to be wrapped immediately should be placed on ice. Wrapping is done in such a manner as to create an eye-appealing product. Crabs are placed belly down in the center of the cellophane. Legs and claws are folded neatly under the crab. The front edge of the cellophane is lifted over the back of the crab and is tucked tightly at the back (Figure 38). This "plumps" the crab somewhat. Wrapping continues by rolling the crab onto its back and folding the cellophane ends under the crab as it is picked up (Figure 39).

Wrapped crabs then are packed in a 3" x 9" x 12" box, belly up with the face and claws raised at a slight angle for a layered appearance (Figure 40). This method of wrapping and packing presents a clean white underside and colored claw tips when opened by a buyer.

The standard 3" x 9" x 12" box will hold the following number of frozen cleaned crabs (fewer will be held if uncleaned): 5 dozen mediums packed in 3 layers with 2 rows per layer, 10 crabs per row; 4 dozen hotels in 3 layers, 2 rows per layer and 8 crabs per row; 3 dozen primes in 3 layers, 2 rows per layer, 6 crabs per row; 2 dozen jumbos in 3 layers, 2 rows per layer, 4 crabs per row; or, 1-1/2 dozen whales in 3 layers, 1 row per layer, 6 crabs per row. Besides packing frozen crabs by number, some large packers are also grading by weight. They feel this gives them more of the consistency in product and portion-control that many restaurants desire. Box weights should be 5-1/2 to 5-3/4 pounds for mediums, 6 to 6-1/4 pounds for hotels and primes, and 5-1/4 to 5-1/2 pounds for jumbos and whales. In a volume operation, these box weights can be adjusted by replacing crabs.

Following wrapping and packing, soft crabs should be frozen as quickly as possible to insure quality. A freezer with a temperature of approximately -20°F and good air circulation is recommended for quick freezing. Placing wooden slats between the boxes will increase air circulation and speed freezing. Boxes should be closed during the freezing process to avoid "freezer burn." Following freezing, soft crabs can be stored at 0°F for up to a year without significant quality loss. However, six months is a more realistic storage time.

Some soft crab producers may wish to consider an alternative to freezing packed boxes. Wrapped soft crabs can be frozen individually on shallow trays and then packed frozen into boxes. This allows for a faster time from cleaning (or live) to freezing, minimizes grading delay brought on by the need to hold boxes until full of the required size soft crab, and provides a top-quality product. It also allows for easy removal from the box by the consumer.

Producers should consider marketing other related items besides top quality soft crabs. In the Chesapeake Bay, peelers are in great demand as fishing bait, often bringing as much as soft crabs. The bait market offers a possible outlet for white sign crabs that have been held too long or for freshly dead peelers. Peelers that die and are not sold as fishing bait can be frozen for later sale if space permits. Frozen peelers, although not as acceptable as hook-and-line fishing bait, are very acceptable as bait for eel pots. During the cleaning process female crab aprons are removed. Rather than discard them, some producers will bag aprons (usually 1 pound packages) and sell them as bait. Soft crab aprons are effective bait for seatrout and other bay fish. Likewise, face parts should not be discarded; these parts make a very good chum bait. Although these products do not command the high prices of soft crabs, in some areas they can augment a crab shedder's income.

Markets may also be found for buffalos (crabs missing an excessive numbers of legs or claws) and paper shells. Potential buyers of these prod-

ucts are more interested in bargain prices than in complete bodies and legs (as restaurant buyers are). Do not overlook neighbors, friends or your own dinner table when it comes to these products.

Shedding Rock Crabs

NOTE: Portions of the following information are taken directly from VIMS Sea Grant Advisory Series No. 7, "Rock Crab: A Potential New Resource," written in 1973 by Paul A. Haefner, Jr., W. A. Van Engel and David Garten.

Rock crabs (*Cancer irroratus*), which historically have been culled and discarded from catches of blue crabs in the winter dredge fishery in Virginia, represent a potentially important resource (Figure 41). Specifically, there appears to be the potential for production of soft-shell rock crabs. Unlike blue crabs, however, rock crabs shed during winter. Traditional soft-shell blue crab shedders could thus extend production and maximize the use of their shedding facilities by utilizing rock crabs. The sale value of soft rock crabs should be equal to or perhaps higher than that of soft blue crabs.

The rock crab is found on the continental shelf and slope from Labrador to South Carolina. Its distribution pattern over its range, however, will vary seasonally; in summer it migrates offshore into cooler waters, moving back inshore during winter.

Rock crabs are found in the southern waters of Chesapeake Bay and in the seaside bays of the Eastern Shore from November through April. They first appear in seaside bays in late October or early November, when the water temperature drops to 60°F. Rock crabs that enter nearshore waters are almost exclusively male crabs.

Rock crabs are often caught along with blue crabs in wire-mesh pots on the Eastern Shore. The pot catch is good until the water temperature drops below 40°F. Blue crab dredgers catch many rock crabs in Chesapeake Bay, particularly on the sandy ledges along Thimble Shoal, Chesapeake and York River entrance channels from December through March. But rock crabs

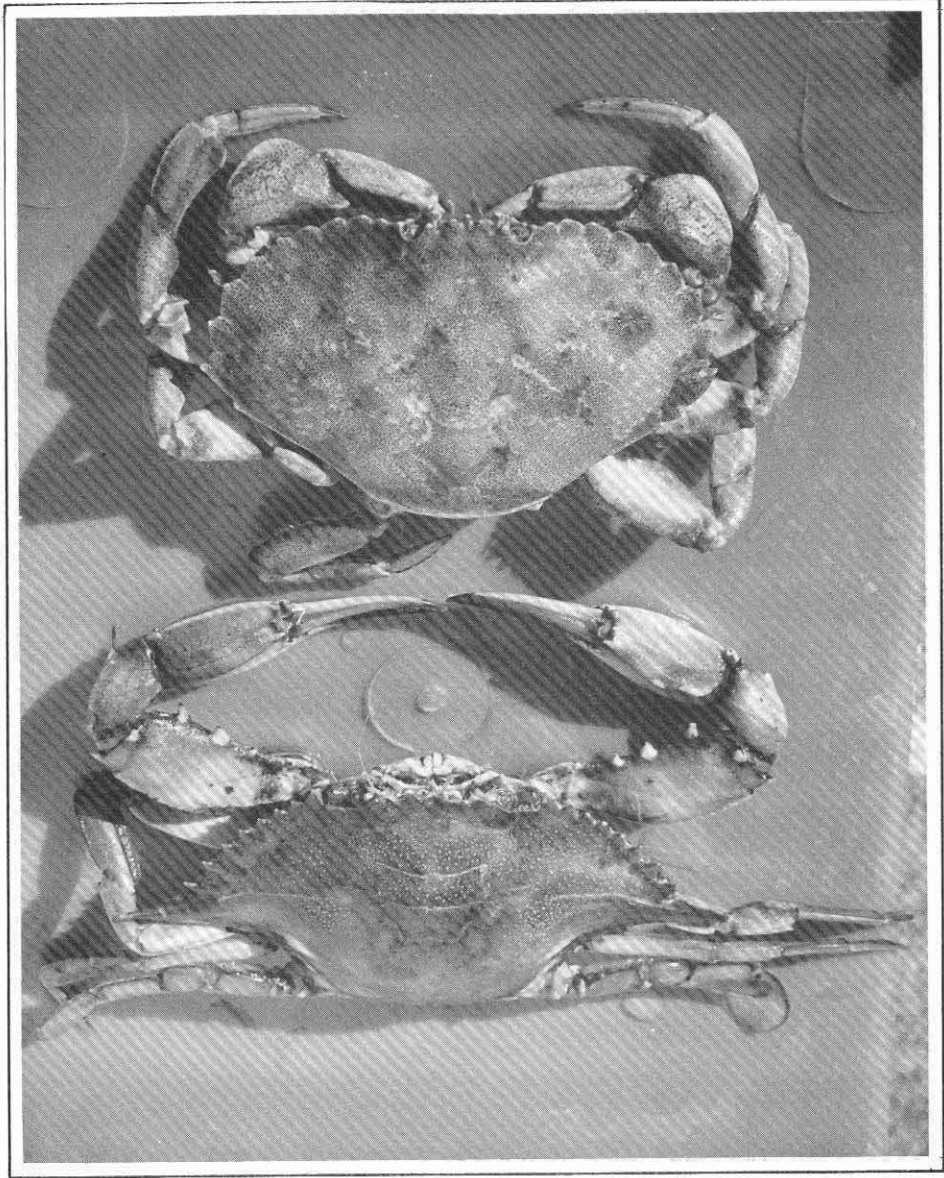

FIGURE 41. Comparison of a rock crab (upper photo) to a blue crab. Note the rounder, stouter body of the rock crab and the absence of a flattened paddle fin.

caught in pots are preferred over those caught by dredge if the crabs are intended to be held for shedding. Dredge-caught crabs may be damaged in the harvesting process and are usually not handled carefully by watermen intent on catching blue crabs.

Unlike blue crabs, rock crabs do not have easily recognized peeler signs. They have no flattened swimming fins that show color signs. Likewise, there are no color changes associated with the abdomen. However, from mid-December through mid-January, peelers make up about three-fourths of the rock crab catch. On rank peelers, the body shell just under the lateral points and above the leg bases is easily cracked with light finger pressure. With experience, it is possible to discern two grades of peelers by this finger pressure method. If when squeezed lightly, this area flexes but does not crack, the crab is a rank peeler, but not yet ready to bust. If the area cracks easily, the crab is a buster. This is the easiest and least damaging way to identify a rank peeler rock crab.

The most successful strategy, however, is to assume that any hard male rock crabs caught during December that are 4 inches or smaller in width will eventually shed. Since shedding does not occur naturally until late December or early January, it is not economical to hold crabs before mid-December. Beginning at this time, male rock crabs should be caught and held in shedding tanks. It then becomes a matter of waiting for them to shed.

The same types of shedding facilities previously described for blue crabs can be used to shed rock crabs. However, it is recommended that a closed system housed in a building be used. With a closed system, both water temperature and salinity can be maintained at favorable levels for rock crab molting. Water temperatures between 45-55°F have been found best for shedding rock crabs. An inside shedding facility will allow for this warmer-than-natural water temperature. As for blue crabs, the salinity of the water in the shedding system should be approximately the same as the area of peeler harvest. Rock crabs prefer high salinity waters, generally above 25 ppt.

Production of soft rock crabs is affected by the intensity and duration of light. A 10-hour light, 14-hour dark cycle is ideal for rock crab shedding; this can be achieved with low intensity artificial lighting in a closed building. Bright light should be avoided. Only minimal lighting, preferably no lighting, is best at night.

After working with blue crabs, a shedder will find rock crabs a pleasure to handle. They tend to be slow moving and not very aggressive. There also is little evidence of cannibalism. For these reasons, many rock crabs can be held in a single shedding tank. The actual number will depend on the size of the tank, water flow and temperature (warmer temperatures make the crab more active). About 300 crabs per 4' X 8' tank is a general rule-of-thumb number.

Because rock crabs must be held a relatively long time before they molt they should be fed. To minimize lowering water quality, it is recommended that live food be supplied. Rock crabs naturally consume all types of molluscs; mussels are a particular favorite food item. They have also been observed eating blue crabs!

The rock crab's shell hardens slowly—much slower than that of the blue crab. The change from early papershell to hard crab takes one month or more at winter water temperatures. However, after shedding they expand to full size within 2 hours, increasing in width approximately 20% before the new shell begins to harden. Soft rock crabs should be left in the water for 4 to 6 hours after shedding to minimize damage that may occur in handling. This allows for great flexibility in the frequency that shedding tanks need to be fished. Tanks should be checked at least every morning and evening.

Soft rock crabs will live only 1 to 2 days under the best of conditions. They do, however, freeze well, without loss of flavor or texture. These facts should enter into a shedder's marketing decision.

Presently, the market for soft rock crabs is not as extensive as that for soft blue crabs. It may be necessary to direct-market soft rock crabs to

restaurants. This has been done successfully in at least two instances. As the production of soft rock crabs increases, markets should open up. For now, however, outlets must be developed by individual producers.

Appendix I

SEA GRANT MARINE ADVISORY SERVICE

New York

New York State Sea Grant Advisory Program
Fernow Hall
Cornell University
Ithaca, NY 14853
607/255-2823

New Jersey

New Jersey Marine Advisory Service
Cook College
P.O. Box 231
New Brunswick, NJ 08903
201/932-9636

Delaware

Marine Advisory Program
University of Delaware
700 Pilottown Road
Lewes, DE 19958
302/645-4256

Maryland

Marine Advisory Program
University of Maryland
College Park, MD 20742
301/314-1280

Virginia

Marine Advisory Program
Virginia Institute of Marine Science
Gloucester Point, VA 23062
804/642-7163

North Carolina

Marine Advisory Program
P. O. Box 8605
North Carolina State University
Raleigh, NC 27695-8605
919/515-2454

South Carolina

Marine Advisory Program
287 Meeting Street
Charleston, SC 29401
803/727-2078

Georgia

Marine Advisory Service
715 Bay Street
Brunswick, GA 31520-4601
912/264-7268

Florida

Marine Advisory Program
University of Florida
P.O. Box 110405
Gainesville, FL 32611-0405
904/392-1837

Mississippi/Alabama

Marine Advisory Program
Mississippi/Alabama Sea Grant Consortium
703 East Beach Drive
Ocean Springs, MS 39566-7000
601/388-4710

Louisiana

Marine Advisory Program
Sea Grant Program Office
Louisiana State University
Baton Rouge, LA 70803
504/388-6290

Texas

Marine Advisory Service
Texas A&M University
College Station, TX 77802
409/845-7524

Appendix II

ADDITIONAL READING

- Bearden, Charles M., David M. Cupka, Charles H. Farmer, III, J. David Whitaker and Steve Hopkins. 1979. Information on establishing a soft shell crab operation in South Carolina. A report to the fishermen. South Carolina Wildlife and Marine Resources Department, Division of Marine Resources, Charleston, SC. 21 pp.
- Cupka, David M. and W. A. Van Engel (editors). 1979. Proceedings of workshop on soft shell blue crabs, September 22, 1979, Charleston, South Carolina. South Carolina Marine Resources Center Technical Report Number 48. 99 pp.
- Haefner, Paul A., Jr. and W. A. Van Engel. 1975. Aspects of molting, growth and survival of male rock crabs, *Cancer irroratus*, in Chesapeake Bay. *Chesapeake Science*, **16**(4):253-265.
- Haefner, Paul A., Jr., W. A. Van Engel and David Garten. 1973. Rock crab: a potential new resource. Virginia Institute of Marine Science, Marine Resources Advisory Series No. 7. 3 pp.
- Jachowski, Richard L. 1969. Observations on blue crabs in shedding tanks during 1968. University of Maryland, Natural Resources Institute, Seafood Processing Laboratory, Reference No. 69-24. 15 pp.
- Oesterling, Michael J. 1982. Mortalities in the soft crab industry: sources and solutions. Virginia Institute of Marine Science, Marine Resource Report No. 82-6. 11 pp.
- Otwell, W. Steven. 1980. Harvest and identification of peeler crabs. Florida Sea Grant Publication MAFS-26. 4 pp.
- Otwell, W. Steven, James C. Cato and Joseph G. Halusky. 1980. Development of a soft crab fishery in Florida. Florida Sea Grant Report #31. 56 pp.
- Paparella, Mike (editor). 1979. Information tips. 79-3. University of Maryland, Marine Products Laboratory, Crisfield, MD. 6 pp.
- Paparella, Mike (editor). 1982. Information tips. 82-2. University of Maryland, Marine Products Laboratory, Crisfield, MD. 11 pp.
- Perry, Harriet M. and Ronald F. Malone (editors). 1985. Proceedings of the National Symposium on the Soft-Shelled Blue Crab Fishery. February 12-13, 1985, Biloxi, MS. 128 pp.

Perry, Harriet M. and W. A. Van Engel (editors). 1982. Proceedings of the blue crab colloquium, October 16-19, 1979, Biloxi, Mississippi. Gulf States Marine Fisheries Commission, Number 7. 235 pp.

Spotte, Stephen. 1979. **Fish and Invertebrate Culture: Water Management in Closed Systems.** Second edition. John Wiley and Sons, Inc., New York, New York. 179 pp.

Warner, William W. 1976. **Beautiful Swimmers: Watermen, Crabs and the Chesapeake Bay.** Little, Brown and Company, Boston. 304 pp.

Wheaton, Fred. 1977. **Aquacultural Engineering.** John Wiley and Sons, Inc., New York, New York. 708 pp.

Appendix III

COMMON TERMINOLOGY OF THE SOFT CRAB INDUSTRY

APRON - flexible abdominal section which folds under the crab body; the crab "tail."

BACKFIN - swimmer or paddle fin; last leg of crab which is flattened for locomotion; reveals color signs of pre-molting.

BARE POTTING - empty pot; regular crab or peeler pot with no bait; catches peelers seeking protection.

BUCK AND RIDER - doublers; mating crabs.

BUCKRAM - post-molted crab in semi-hard shell condition; shell is brittle and unmarketable as soft crab.

BUFFALO CRABS - soft-crab missing legs or claws.

BUSTER - first stage of molting; crab beginning to back out of old shell.

DEAD MAN'S FINGERS - crab gills or "lungs" found just below the carapace.

DOUBLER - pair of crabs in mating position, male carries female; buck and rider.

ECDYSIS - (ek-di-sis) scientific term for crustacean molting process.

EPIMERAL LINE - ridged line running along the "face" of the crab; below the carapace and on each side of the mouth; acts as a hinge during molting.

FAT CRAB - full crab; muscle tissue completely fills shell; crab is at maximum weight for existing shell size.

FLOATS - floating boxes designed to hold peelers during shedding.

GREEN CRAB - crab between molts; non-peeler crab; also uncooked crab.

HAIR SIGN - white sign crab.

HOTELS - market size (4-4 1/2 inch width).

JIMMIES - larger male blue crabs, jimmy dick or jimmy channeler are largest.

JIMMY POTTING - jimmies are placed in a crab trap as live bait to attract females looking for a mate.

JUMBO - market size (5-5 1/2 inch width).

MEDIUMS - smallest market size (3 1/2-4 inch width).

MOLTING - ecdysis; process of shedding old hard shell.

NICKING - breaking the movable "finger" of the crab claws to prevent cannibalism and damage.

PAN-READY - soft crabs packaged for sale with eyes, mouth parts and gills removed; larger crabs may have soft carapace removed.

PAPER-SHELL - unfavorable leathery condition of the shell on soft crab beginning to harden.

PEELER - hard crab in pre-molting condition, ideal for shedding operations.

PEELER POUND NET - wire pound net used specifically to harvest peelers in Chesapeake Bay.

PINK SIGN - pink line on new forming shell visible through the old shell on the backfin about one week from molting.

PRIME - market size (4 1/2-5 inch width).

RANK - peeler crab with true red sign; only a few hours from molting.

RED SIGN - red line of the new forming shell visible through the old shell on the backfin about 1-3 days before molting.

SALLY CRAB - she-crab, immature female with triangular apron.

SCRAPE - small (1 1/2 x 4 foot) bar type trawl specifically designed for harvesting peelers from grass beds.

SHE-CRAB - immature female with triangular apron.

SHEDDING - process of molting; ecdysis; commonly used to refer to the commercial process.

SHED - empty old hard shell remaining after molting.

SNOT CRAB - white sign crab; snot refers to fluid released from wounds or nicks.

SOOK - mature female crab with semicircular shaped apron.

TANKS - on-shore shedding facilities built to hold peelers in a shallow flow of pumped water.

TERMINAL MOLT - last molt for a blue crab; female crab can only mate during the terminal molt; when the female apron shape changes from triangular to half moon.

TRAP DOOR - section on the top of the upper segment (merus) of the claws which opens to allow the larger, lower claw section (propodus) to be extracted during molting.

WATER GALL - windjammer, white crab; hard crab immediately after molting; muscle tissue does not completely fill shell space; crab is light for the shell size.

WHALES - slabs, market size (5 1/2 inch width).

WHITE SIGN - white line of new forming shell visible through the old shell on the backfin about two weeks before molting.

WIDTH - crab size; measured distance between tips of longest lateral spines.

Appendix IV

DETERMINING AMOUNT OF WATER IN A SHEDDING SYSTEM

1. Amount in gallons

- a) First determine the water volume in one tank.

For example purposes, use a 4' X 8' tank with 4" of water.

Therefore, in one tank 4' X 8' with 4" of water there will be 10.56 cubic feet of water.

- b) To convert this to gallons, multiply the number of cubic feet of water by 7.5 gallons per cubic foot of water.

$10.56 \text{ cubic feet of water} \times 7.5 \text{ gallons/cubic foot} = 79.2 \text{ gallons.}$

Therefore, there will be almost 80 gallons of water per 4' wide, 8' long tank filled with 4" of water.

- c) To determine the volume in gallons of water in your entire shedding system, simply multiply the number of gallons in one tank by the total number of tanks.

10 tanks (4' X 8' with 4" water)

79.2 gallons/tank

$10 \times 79.2 = 792 \text{ gallons of water in all tanks}$

If you have additional tanks or reservoirs within your system, simply calculate the volume of water held in each and follow the above examples to determine number of gallons of water.

2. Amount in pounds of water

- a) Using the above information, determine the number of gallons of water per tank.

- b) To convert this to pounds, multiply the number of gallons of water by 8.3 pounds per gallon of water.

$79.2 \text{ gallons} \times 8.3 \text{ pounds/gallon} = 657.4 \text{ pounds}$

Therefore, in a 4' wide, 8' long tank filled with 4" of water, the weight of the water alone will be about 657 pounds.