

Measurements of the Shape of Sand Ripples

Jerome P.-Y. Maa¹ S.-H. Ou² C.-J. Huang³

ABSTRACT

Laboratory experiments have been conducted for determining what would be the correct selection of acoustic devices for measuring the shape of sand ripples. The results reveal that a tone-burst type signal generator with 1 or 2 watts will be sufficient to drive the transducer. A transducer with focus and reasonable size would be the best choice. While measuring, the ratio of measuring distance (between the transducer and sea floor) and the transducer's focus length should be maintained at a ratio between 90% and 110% for best results.

砂漣形狀的量測

馬平亞 歐善惠 黃清哲

摘要

本文主要是在實驗室中藉由實驗確定量測砂漣形狀時如何選擇正確的聲學儀器。結果顯示具備1至2瓦(watt) tone-burst型的信號產生器已足夠驅動聲壓換能器(transducer)。量測時我們發現量測距離(聲壓換能器與海底之間)與聲壓換能器焦距的比值在0.9至1.1之間時，能得到最好的量測結果。

1. Introduction

Wave-induced ripple geometry is an important information to determine the bottom roughness in the study of benthic boundary processes. To measure the shape of ripples is a difficult task, especially at fields, because of the lack of a proper instrument. Most available data were obtained by diver's visual observations that can only be performed under fair weather conditions.

Acoustic approach is the only feasible method to acquire this kind of information. Echo sounding devices for measuring the water depth is a typical example of applications. Because of the different objectives (high resolution at the bed surface), however, a commercially available echo sounding device, e.g., supersonic altimeter, is not accurate enough for measuring the shape of ripples. Critical issues regarding the use of acoustic approach, e.g., the selection of sensor, the exciting signals, and the possible performance, are still not well documented.

In this study, we have examined the possible choices of acoustic transducers, the proper method to drive the transducer, and the associated responses of each selected transducer. The objectives are aimed to address the following questions: (1) What kind of acoustic signal generating device is capable and feasible of driving a transducer? (2) How to select and

1. Assoc. Prof., Virginia Institute of Marine Science/School of Marine Science, College of William and Mary, Gloucester Point, VA 23062, Email: maa@vims.edu.
2. Prof., Dept. of Hydraulic and Ocean Engineering, National Cheng-Kung University, Tainan, Taiwan, R.O.C.
3. Assoc. Prof., Dept. of Hydraulic and Ocean Engineering, National Cheng-Kung University, Tainan, Taiwan, R.O.C.

operate the transducer? (3) What kind of performance can be expected?

Instrumentation

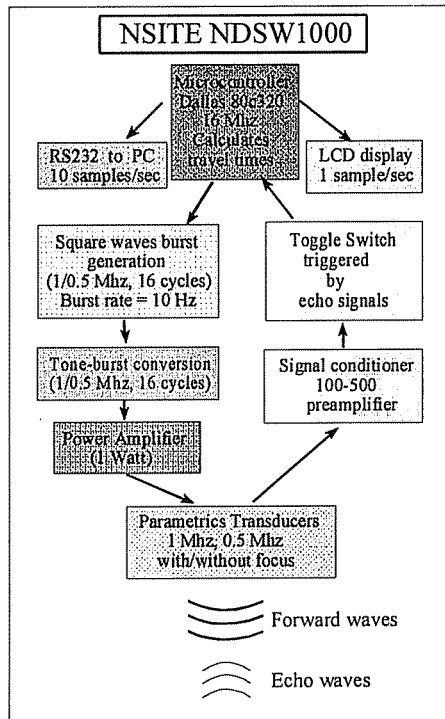

Fig. 1. A Systematic Diagram of the Instrument Selected for the Experiments.

The typical method of generating acoustic waves is using a pulse generator to produce repeated pulses (at a rate of 10 - 50 Hz) to excite an acoustic transducer. This method is not efficient in terms of acoustic wave generation. Thus, high power (i.e., high cost) is inevitable to obtain sufficient acoustic energy. A pilot test carried out at the National Cheng-Kung University indicated that very high energy pulse generator is needed for the proposed study. For reducing the cost, we have selected a device (Nsite, NDSW1000) that produces repeated tone bursts (16 cycles of 1 Mhz waves) at a rate about

10 Hz. Because of the high efficiency for producing acoustic waves at a transducer's resonant mode, limited power (< 2 watts) is sufficient for carrying out the experiment. A systemic diagram of the instrument is presented in Fig. 1 for showing the principal of how it works.

The three selected transducers (Parametric=immersion transducer) are all operated at a frequency of 1.0 Mhz. The differences are size and focus length: (1) Size = 1.27 cm without focus; (2) Size = 2.54 cm with focus length, $F = 8.6$ cm; and (3) Size = 3.81 cm with $F = 19.43$ cm. The choice of 1 Mhz is based on previous experience on acoustic device for reasonable attenuation and angular spreading (Maa et al. 1997). The selection of different size and focus is aimed to address the second question stated in the introduction.

2. Experimental Setup

We have selected two typical ripple geometries for test. One for a relatively large and steep ripple, and the other is a relatively small ripple. The large ripple had a ripple height, η , of 2.5 cm and ripple length, λ , of 15 cm. This ripple shape was generated using a sine function with amplitude of 1.25 cm and length of 15 cm. Two consecutive ripple forms were put together with a flat section of 5 cm long on each side. Medium sand was used to fill up the form and carefully smoothed with the form in order to build a loose sand ripple bed for test. Total length of the ripple model is 40 cm (Fig. 2).

The small ripples selected has $\eta = 1$ cm and $\lambda = 6$ cm. It was prepared with the same procedure as the large ripple model. Instead of two ripples, the experimental section has five ripples and the total length was also 40 cm. The two ripple models represent the maximum and minimum size of ripple that could be generated at fields and laboratories, respectively.

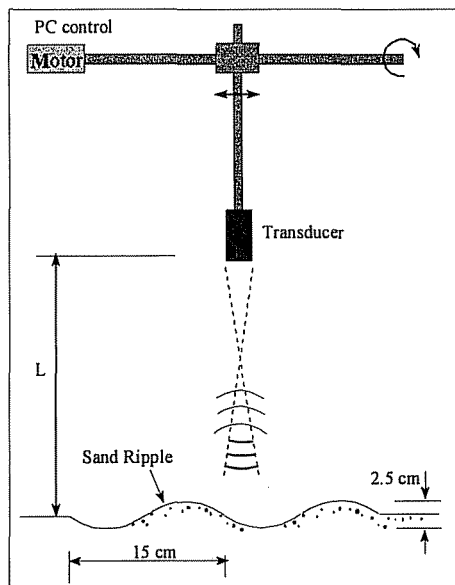

Fig. 2. A Diagram to Show the Experimental Setup.

In order to measure the ripple geometry, we made a linear mover (Fig. 2) that changes the rotation motion of a step motor to linear motion in x direction. The transducer was mounted on the linear mover. Using a PC to control the step motor, we can move the transducer linearly across the ripple bed with a selected resolution of 0.63 cm. Other resolution is possible, but not attempted yet.

The ripple model was put in a small water tank, and the transducer was mounted at a distance L above the ripple bed (Fig. 2). Eight different $L = s$ were arbitrary selected to check the performance of selected transducers. The PC controlled linear mover moved the transducer to a new location, 10 readings were collected and the averaged values of acoustic wave travel distance were recorded in the PC for later analysis. For a selected observation distance, five repeated experiments were conducted to check the repeatability.

3. Results and Discussion

In general, the five repeated experimental results for each selected observation position, L , do not show noticeable difference (Figs. 3 and 4) for the two large transducers with focus. The transducer without focus only able to detect the ripple at a very close position, and the results showed a lot of scatter (Fig. 5). This phenomenon may be caused by the inefficiency of a small transducer size (1.27 cm) for generating acoustic waves, and thus, not sufficient for a long distance measurement. For this reason, experiments on this transducer stopped at this point.

Inasmuch as the averaged echo signals (dashed lines in Figs. 3 and 4) are closely representing each individual measurement, we can use this information alone to check the performance of a transducer with different size, focus, and observation distance, L .

The measured distances between the transducer and the sandy ripple surface can be plotted together for comparison (Figs. 6 to 9). In each plot of a measured ripple shape (the dashed line), the

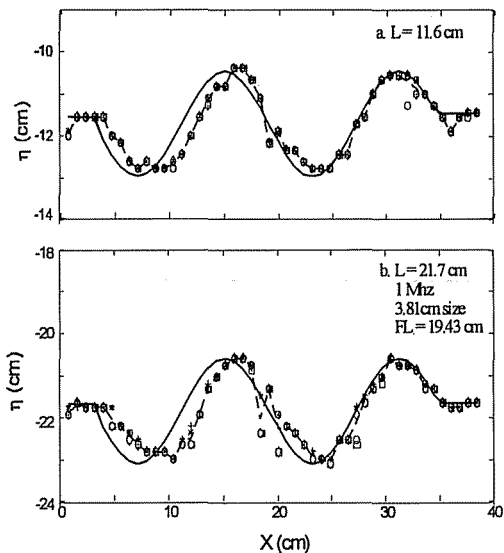

Fig. 3. Selected Results Show the Five Repeated Measurements (the symbols), the Averaged Measurements (the dashed lines), and the Background-truth (Solid lines) using an 1 Mhz transducer with size = 3.81 cm and focus = 19.43 cm. (a) $L = 11.6$ cm; (b) $L = 21.7$ cm.

background-truth is also plotted as the thin solid line for comparison.

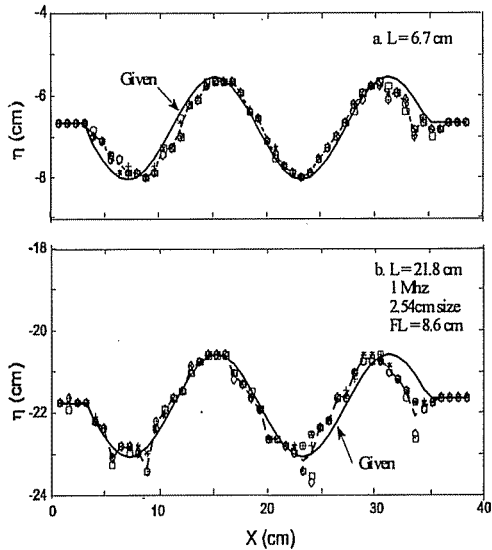

Fig. 4. Selected Results Show the Five Repeated Measurements (the symbols), the Averaged Measurements (the dashed lines), and the Background-truth (Solid lines) using an 1 Mhz transducer with size = 2.54 cm and focus = 8.6 cm. (a) $L = 6.7$ cm; (b) $L = 21.8$ cm.

It can be seen for the transducer with a 19.43 cm focus, the performance was the best if the measuring distance, L , is between 17 and 22 cm (bottom three dashed lines in Fig. 6), which is within 85% of the focus length. The measurements with a much close observation position, however, were not good (see the top two dashed lines in Fig. 6). The performance improved as the observation distance, L , approached the focus length.

For the transducer with a focus length of 8.6 cm, the results are equally well for the top five measurements given in Fig. 7 (with $L = 4.1, 6.5, 9, 11.5$ and 14.2 cm). These five values of L is approximately within 50% of the focus length, 8.6 cm. The board range of operation distance may be because of the best transducer size (2.54 cm) and the focus

length.

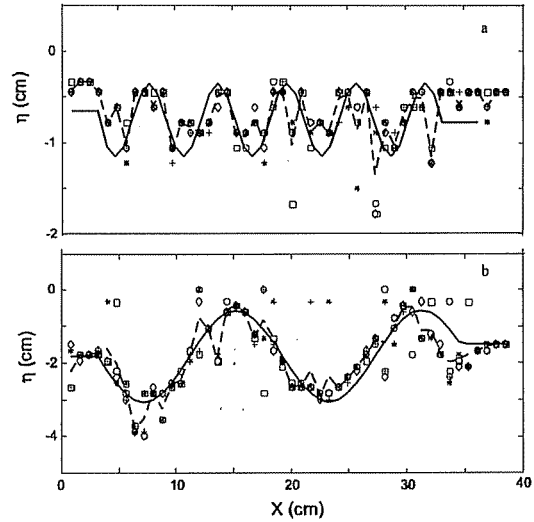

Fig. 5. Selected Results Show the Five Repeated Measurements (the symbols), the Averaged Measurements (the dashed lines), and the Background-truth (Solid lines) using an 1 Mhz transducer with size = 1.27 cm without focus. (a) small ripples; (b) large ripples.

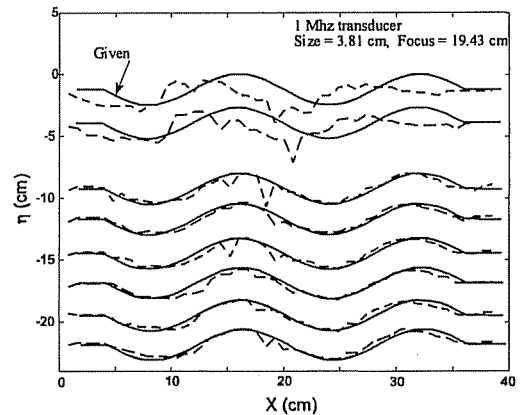

Fig. 6. Comparison of the Averaged Measurements (dashed lines) and Background-truth (Solid lines) at Different Observation Locations for the 1 Mhz Transducer with Size = 3.81 cm and Focus = 19.43 cm for the Large Ripples.

For checking the performance of detecting small

ripple size, these two selected transducers are all capable of producing very good results if the observation distance, L , is restricted to be closer to the focus distance, i.e., $F/L \approx 1$. For example, the measurements with $L = 20$ cm for the transducer with focus length = 19.43 cm is excellent (the second dashed line from bottom in Fig. 8). The measurements with $L = 5.5, 8,$ and 10 cm for the transducer with focus length = 8.6 cm are all excellent (the 2nd, 3rd, and 4th dashed lines from top in Fig. 9).

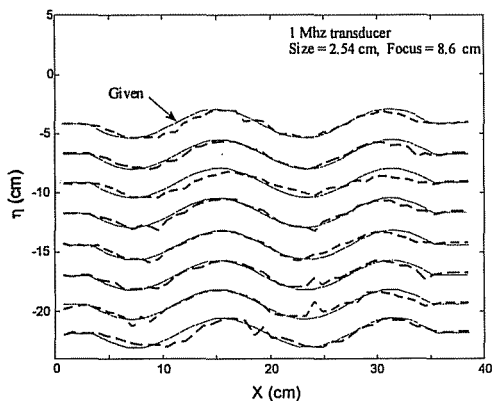

Fig. 7. Comparison of the Averaged Measurements (dashed lines) and Background-truth (Solid lines) at Different Observation Locations for the 1 Mhz Transducer with Size = 2.54 cm and Focus = 8.6 cm for the Large Ripples.

Figures 6 - 9 indicates that the transducer size is immaterial for getting the accurate measurements of ripple shape. It is the ratio of focus length, F , and observation distance, L , that plays the most important role for getting accurate measurements. In general, $F/L \approx 1$ can produce the best measurements.

Inasmuch as the selected ripple models represent the possible maximum ripple size at fields and laboratories, this study identified a suitable device and a proper procedure to obtain accurate measurements of ripple shape.

This study is limited with only one operating frequency, 1 Mhz. A lower frequency is possible for extending the observing distance, if needed. This is because the lower dissipation rate for lower frequency

waves travel in water (Hamilton, 1969). For the reason of being capable of detecting loose, fine sediments, however, the operation frequency cannot be too much lower than 0.5 Mhz (Kirby, 1988). Test on 0.5 Mhz transducers with a much large focus, on the order of 50 cm, is currently under planning.

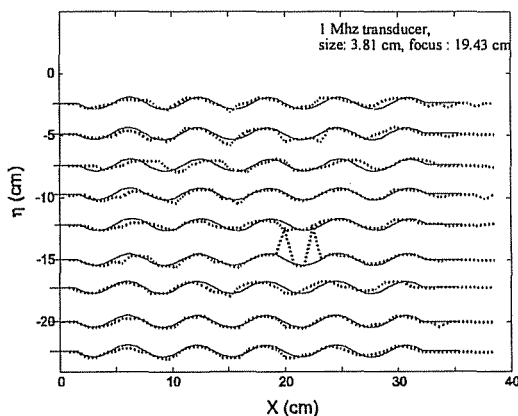

Fig. 8. Comparison of the Averaged Measured Small Ripples (dotted lines) and Background-truth (solid lines) at Different Observation Locations for the 1 Mhz Transducer with Size = 3.81 cm and Focus = 19.43 cm.

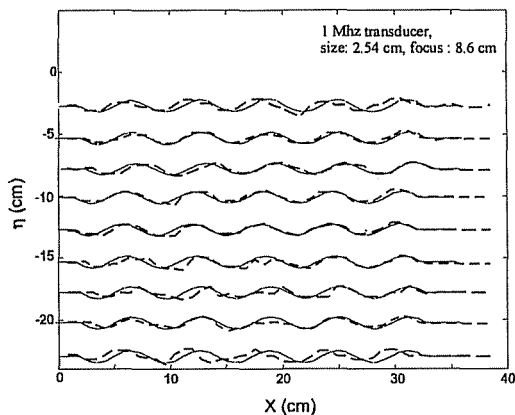

Fig. 9. Comparison of the Averaged Measured Small Ripples (dashed lines) and Background-truth (solid lines) at Different Observation Locations for the 1 Mhz Transducer with Size = 2.54 cm and Focus = 8.6 cm.

A possible application of the know-how for accurate ripple shape measurements is for field

measurements of directional ripple spectrum that is similar to directional wave spectrum. The sampling rate for obtaining a ripple spectrum, however, is low because of the slow pace of a ripple propagation speed. Using four sets of the above described instruments to set up a linear array (Horikawa, 1988) for directional ripple spectrum measurements should be able to achieve.

4. Conclusions

Using acoustic approaches to measure ripple shape seems a simple issue. Actually, cautions must be given on the selection of instruments, transducers, as well as the correct procedure to carry out measurements. With the correct selection on instruments and operation procedure, accurate ripple shape can be measured.

A tone-burst type signals generator is a much better choice because of the low power requirements, which means field operation is more feasible. Understanding the operation environments is also essential for selecting the right transducer. Depends on the most possible distance between the transducer and the sea floor, a transducer with focus length equal to that distance will perform the best, i.e., provide the most accurate results. The transducer size, although is not a critical issue, should be selected for better producing acoustic waves. In general, a large size transducer can produce more acoustic energy than a small size transducer for a fixed electronic signal input. On the other hand, the larger the transducer, the higher the cost. Thus, an optimum selection of transducers depends on the operation condition.

Acknowledgment

Support of this study from the research leave of the Virginia Institute of Marine Science, College of William and Mary is sincerely acknowledged.

References

1. Hamilton, E.L. (1969) *Sound Velocity, Elasticity, and Related Properties of Marine Sediments*, North Pacific, TP 144, Naval Undersea Research and Development Center, San Diego, CA.
2. Horikawa, K. (1988) *Nearshore Dynamics and Coastal Processes*, University of Tokyo Press, Tokyo, Japan.
3. Kirby, R. (1988) "High Concentration Suspension (Fluid Mud) Layers in Estuaries," in *Physical Processes in Estuaries*, Eds. J. Dronkers and W. van Leussen, Springer-Verlag, pp. 463-487.
4. Maa, J. P.-Y., K.-J. Sun, and Q. He (1997) "Ultrasonic Characterization of Marine Sediments," *Marine Geology*, 141, pp. 183-192.