

DISINFECTION EFFICIENCY AND RELATIVE TOXICITY
OF CHLORINE AND BROMINE CHLORIDE
A PILOT PLANT STUDY IN AN ESTUARINE ENVIRONMENT.

By
Norman E. LeBlanc
Hampton Roads Sanitation District Commission
Virginia Beach, Virginia 23455

Morris H. Roberts Jr.
Virginia Institute of Marine Science
Gloucester Point, Virginia 23062

and

Donnie R. Wheeler
Hampton Roads Sanitation District Commission
Virginia Beach, Virginia 23455

FINAL REPORT

TO

Coast Plains Regional Commission,
under the auspices of
the Virginia Interagency Task Force on Chlorine

Special Report in Applied Marine Science
and Ocean Engineering
No. 206

Virginia Institute of Marine Science
Gloucester Point, Virginia 23062
William J. Hargis, Jr.
Director

October, 1978

DISINFECTION EFFICIENCY AND RELATIVE TOXICITY
OF CHLORINE AND BROMINE CHLORIDE
A PILOT PLANT STUDY IN AN ESTUARINE ENVIRONMENT.

By

Norman E. LeBlanc
Hampton Roads Sanitation District Commission
Virginia Beach, Virginia 23455

Morris H. Roberts Jr.
Virginia Institute of Marine Science
Gloucester Point, Virginia 23062

and

Donnie R. Wheeler
Hampton Roads Sanitation District Commission
Virginia Beach, Virginia 23455

FINAL REPORT

TO

Coast Plains Regional Commission,
under the auspices of
the Virginia Interagency Task Force on Chlorine

Special Report in Applied Marine Science
and Ocean Engineering
No. 206

Virginia Institute of Marine Science
Gloucester Point, Virginia 23062
William J. Hargis, Jr.
Director

October, 1978

ACKNOWLEDGEMENTS

The Interagency Task Force on Chlorine received both technical and financial assistance from the Ethyl Corporation. Mr. John F. Balhoff of Ethyl Corp. designed the pilot plant system. Dr. J. Michael McEuen of Ethyl Corp. gave advice on experimental design, chemical analysis and other technical matters. In addition, Ethyl Corp. made available pilot plant equipment and bromine chloride for the study.

On-line halogen residual analyzers and the prototype bromine chloride evaporator were made available by Capitol Control Corp.

Dr. J. Donald Johnson of the University of North Carolina at Chapel Hill provided technical advice several times during the study and kindly reviewed this manuscript.

The authors wish further to acknowledge the support and advice of the various members of the Interagency Task Force on Chlorine, in particular Mssr. James Douglas, Norman Larsen, John R. Sutherland, and David Chance. The Marine Resources Commission obtained funds from the Coastal Plains Regional Commission to supplement funds provided by Ethyl Corporation. These added funds allowed significant expansion of the study.

The Virginia State Water Control Board made available a trailer for temporary laboratory space and a high speed pump to supply diluent water to the test facility. Their cooperation is gratefully acknowledged.

TABLE OF CONTENTS

Acknowledgements	ii
Section I	
Introduction	1
Section II	
Conclusions	3
Section III	
Waste Water Treatment System	4
James River STP	4
STP Effluent Characteristics	4
Pilot Plant	7
Chlorine Disinfection Pilot System	7
Bromine Chloride Disinfection Pilot System	11
Pilot Plant Effluent Characteristics	12
Section IV	
Pilot Plant Disinfection Efficiencies	18
Introduction	18
Materials and Methods	18
Results	19
Disinfection Characteristics	19
Residual Characteristics	23
Discussion	32
Section V	
Toxicity Studies	34
Introduction	34
Materials and Methods	34
General	34
Dilutor System	35
Test Animals	36
Experimental Designs	38
Environmental Parameters	40
Results	42
Experiment 1	44
Experiment 2	46
Experiment 3	49
Experiment 4	52
Experiment 5	53
Discussion	55
Section VI	
References	61

SECTION I
INTRODUCTION

Chlorination has been the principal wastewater disinfection method practiced during this century. The need for wastewater disinfection has been well documented. However, there has been increasing evidence that byproducts of the chlorination process may create adverse environmental impacts¹. Studies have shown adverse effects on fauna exposed to excessive quantities of chlorinated sewage effluents in fresh and estuarine systems^{2,3,4}. Recent studies dealing with the reactions of chlorine with organics have shown that chlorinated organics may be formed during the chlorination of domestic water supplies and waste treatment effluent^{5,6}. Some of these compounds, including some trihalomethanes, are alleged carcinogens and/or mutagens^{7,8,9,10}. It remains to be determined whether the amounts produced during disinfection are ecologically significant.

The EPA has suggested that modifications of chlorination practices or alternate disinfectants should be used to reduce the amount of residuals reaching receiving waters. In this regard, bromine chlorine as a wastewater disinfectant appears to have some advantages over chlorine due to the instability of its residual and increased biocidal activity of bromamines as compared to chloramines^{11,12}.

The present study was conducted by the Virginia Interagency Task Force on Chlorine to compare the relative merits of bromine chloride and chlorine as wastewater disinfectants. Operational and disinfection

qualities of both halogens and the relative toxicities of the treated effluents were studied in a pilot scale system. Three specific objectives were pursued; 1. an evaluation of the relative disinfection capabilities of the two halogens; 2. an assessment of the toxicity of each effluent stream to juvenile spot; and 3. an analysis of the halogenated organics produced in treated and disinfected effluent. The results of studies directed at the first two objectives are the subject of this report. Results of chemical analyses of halogenated organics in treated and disinfected sewage effluents will be the subject of a subsequent report.

SECTION II

CONCLUSIONS

1. The prototype system for the application of bromine chloride for wastewater disinfection is inadequate. Improvements must be made to better control the dosage and residual before large scale application of bromine chloride can be accomplished.

2. After the initial halogen demand has been satisfied, the bromine chloride residuals are unstable with >90% decay over a 30 minute contact time. Chlorine residuals for the same contact time showed <10% decay.

3. Under optimized operating conditions both halogens were able to meet the NPDES requirements for disinfection. With these conditions, it required approximately 80-85% as much bromine chloride as chlorine in order to meet these standards and produced 30 minute bromine chloride residuals at least an order of magnitude less than those for chlorine.

4. Pilot plant effluents with either halogen diluted to typical receiving water levels were non-toxic to juvenile spot.

5. The 96-hr. and 144-hr. LC50's for chlorine residual were 0.23 mg/l, for bromine chloride, 0.25 mg/l. These levels could only be achieved with unrealistically high applied halogen doses in excess of pilot plant capabilities.

SECTION III
WASTEWATER TREATMENT SYSTEM

JAMES RIVER STP

The James River STP is a 15 MGD conventional waste activated sludge plant located in Newport News, Virginia, within the Hampton Roads Sanitation District (HRSD). The plant influent is comprised mainly of domestic wastewater with approximately 15% industrial flow. The treated effluent is disinfected with chlorine before being discharged into the James River estuary (Figure 1). Chlorine dosage is manually controlled to maintain a total chlorine residual of 1.5-2.5 mg/l following 30 minute contact time. Chlorine residuals are determined hourly by amperometric titration.

STP EFFLUENT CHARACTERISTICS

The monthly average effluent characteristics for flow, biochemical oxygen demand (BOD), total suspended solids (TSS), ammonia-nitrogen ($\text{NH}_3\text{-N}$), nitrate-nitrite-nitrogen ($\text{NO}_3\text{-NO}_2\text{-N}$), total kjeldahl nitrogen (TKN), and total organic carbon (TOC) are presented in Table 1. These data show that during the test period the plant experienced varying degrees of biological nitrification which resulted in periods of extremely low ammonia levels in the effluent.

In addition, the plant experienced sporadic sludge bulking, which caused increases in effluent suspended solids up to 500 mg/l. These periods were generally of short duration (one to three hours) and were

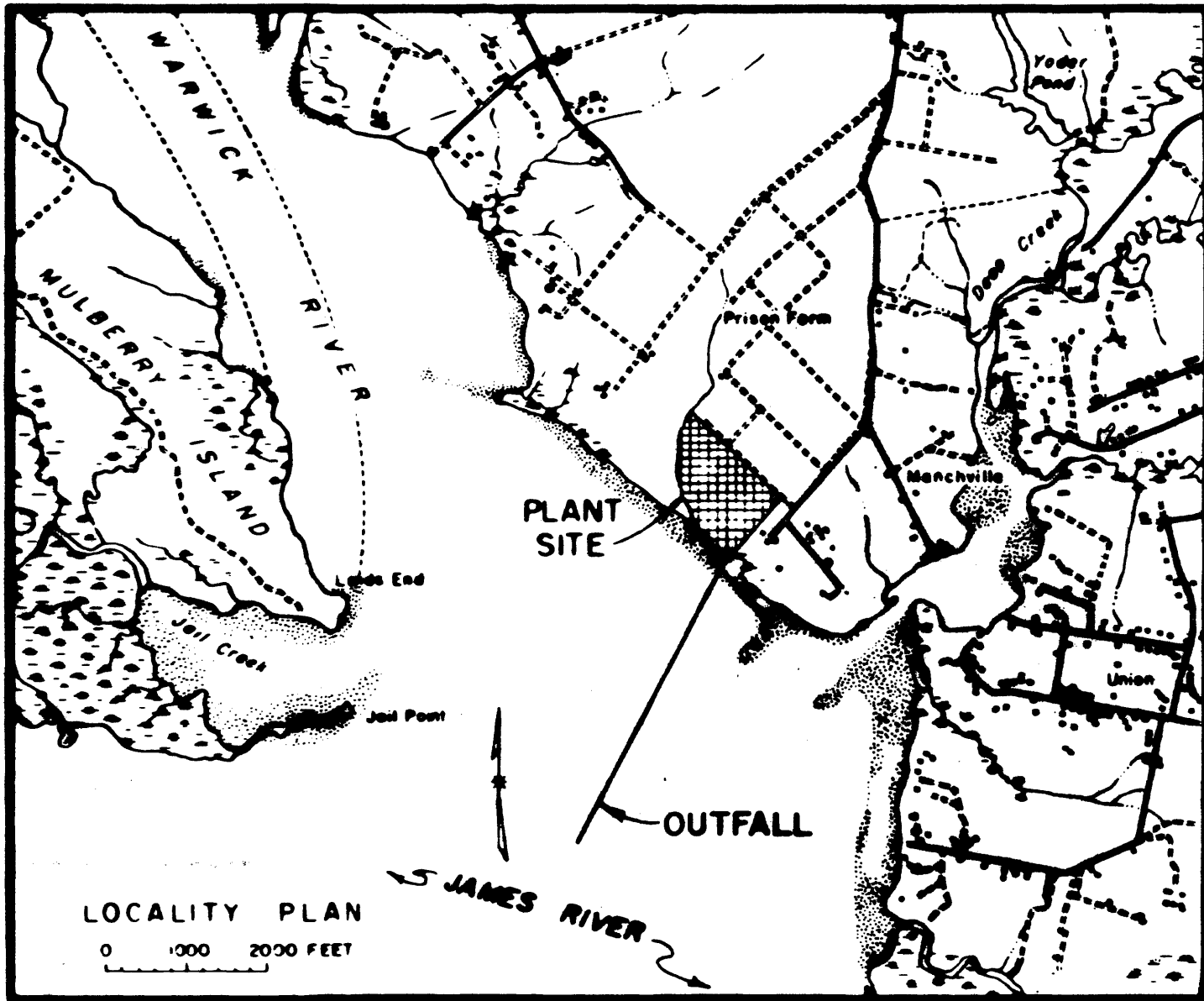

FIGURE I. Hampton Roads Sanitation District Commission
James River Treatment Plant Outfall Location.

TABLE 1
JAMES RIVER STP UNCHLORINATED EFFLUENT CHARACTERISTICS

<u>Month</u>	<u>Flow MGD</u>	<u>pH</u>	<u>BOD₅ (mg/l)</u>	<u>TSS (mg/l)</u>	<u>NO₃-NO₂-N (mg/l)</u>	<u>NH₃-N (mg/l)</u>	<u>TKN (mg/l)</u>	<u>TOC</u>
May	12.0	6.6	26	28	*	*	*	*
June	11.2	6.4	12	12	9.3	2.9	5.6	15.5
July	13.3	6.7	7	8	8.6	3.3	4.6	13.1
August	11.8	6.8	22	36	3.5	7.9	19.4	9.8

*Analyses not performed.

operationally controlled by the application of synthetic polymer and alum.

PILOT PLANT

A pilot plant was constructed which consisted of parallel chlorine and bromine chloride disinfection systems. The disinfection systems were designed by the Ethyl Corporation and built, operated and maintained by HRSD. Each unit was designed to disinfect 0.14 MGD (100 gpm) of treated wastewater from the James River STP. A schematic of the pilot plant is presented in Figures 2, 3, and 4.

Chlorine Disinfection Pilot System

Chlorine gas was fed from 150 lb cylinders using a cylinder-mounted Capitol Controls Company Advance Model Chlorinator. The chlorine was contacted with the 100 gpm treated effluent stream via a standard vacuum injection system. Following contact with the chlorine, a 20 gpm sidestream was diverted to a 30 minute contact tank and the remaining flow was discharged into the James River STP outfall. Effluent from the 30 minute contact tank was diverted to the injection system (to create a vacuum at the injector), the bioassay unit and the continuous residual analyzer (Advance Series 870 Chlorine Analyzer, Capitol Control Co.).

Chlorine dosage was manually adjusted to maintain a desired chlorine residual after 30 minute contact. The system was designed to obtain a maximum chlorine dosage of 16.5 mg/l.

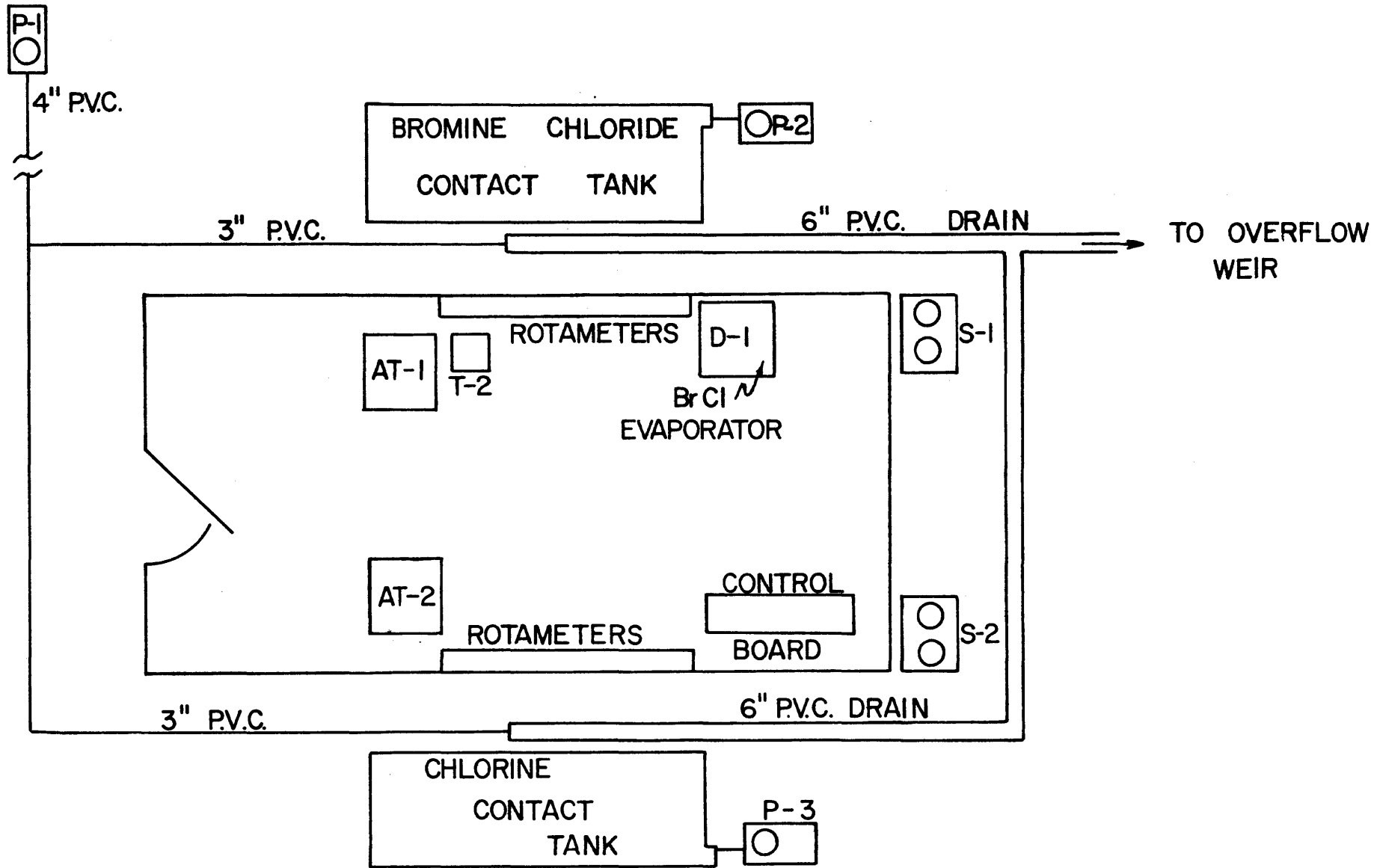

Figure 2. Diagrammatic representation of the pilot plant disinfection units.

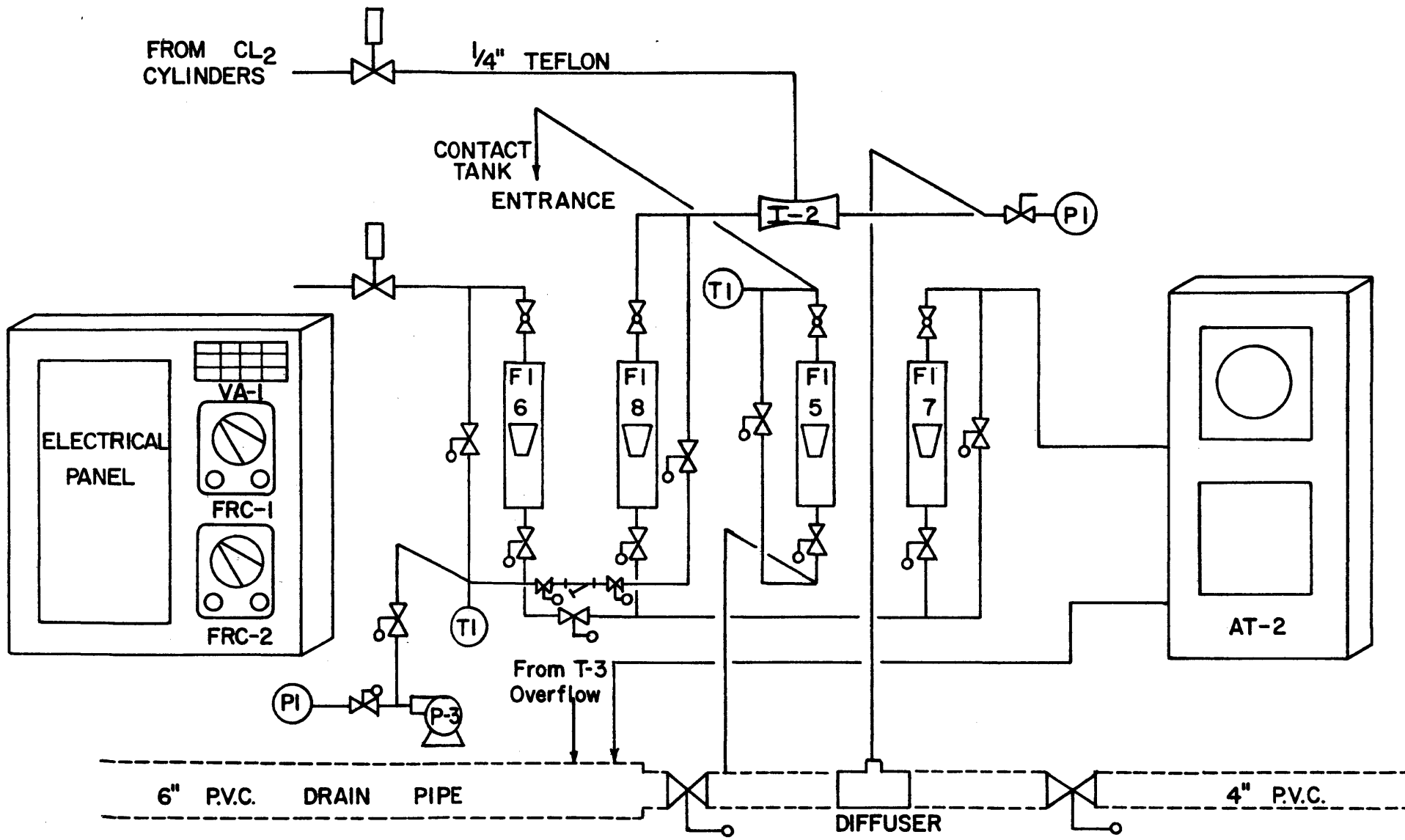

Figure 3. Flow schematic for pilot plant chlorine disinfection unit.

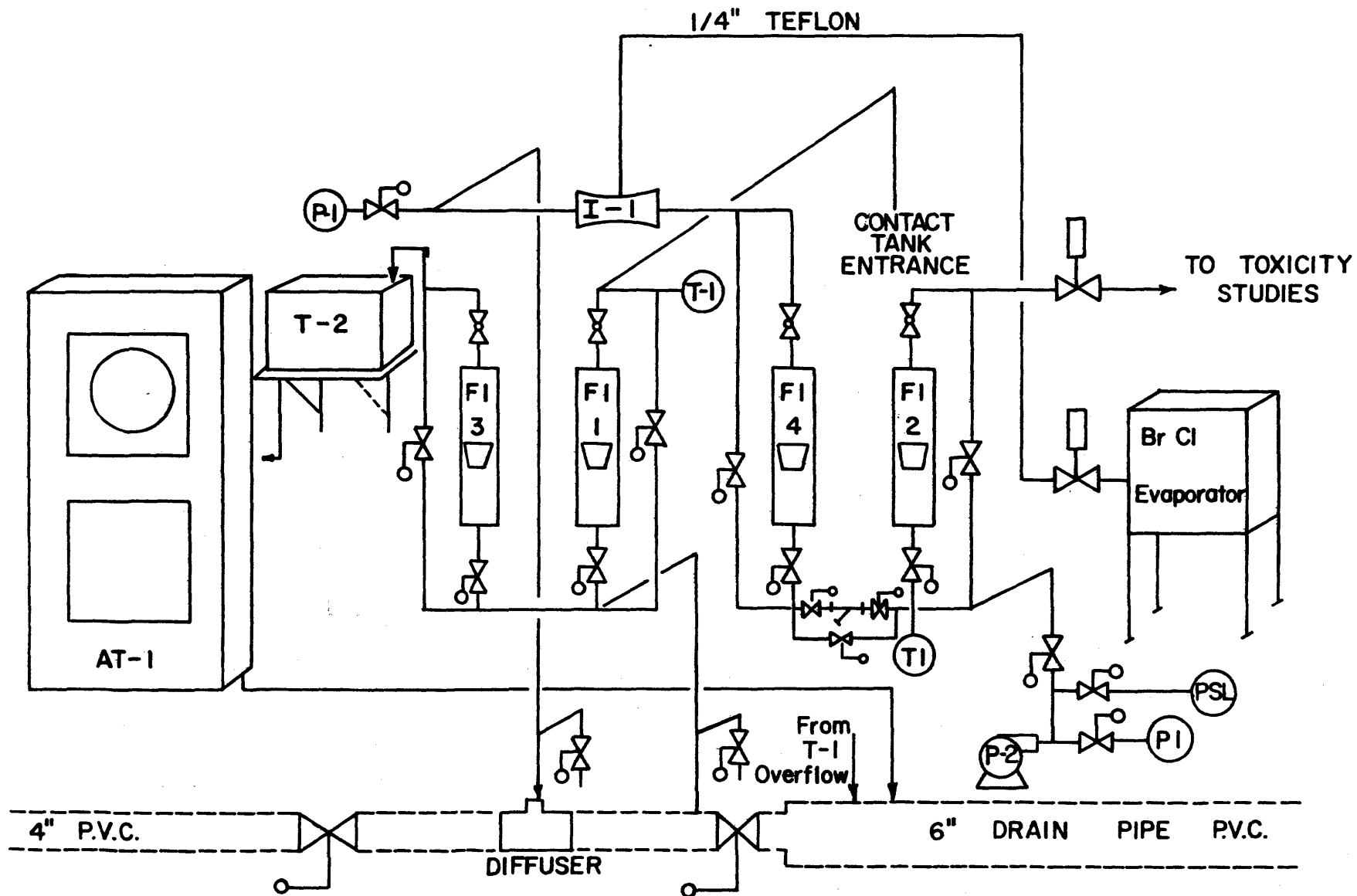

Figure 4. Flow schematic for pilot plant bromine chloride disinfection unit.

Initial chlorine residuals of 2.0 mg/l produced essentially a complete kill of fecal coliforms. During the remainder of the study, chlorine residuals were maintained between 1.0-1.5 mg/l.

Bromine Chloride Disinfection Pilot System

The operation of this system was similar to that for chlorine except that the bromine chloride was supplied as a liquid and had to be vaporized prior to injection. To accomplish this, liquid bromine chloride was supplied to an 88°C water bath dip tube internal heating chamber under 30 psi. The bromine chloride gas was then released to the vacuum injection system through a vacuum release regulator for contact with the 100 gpm effluent stream.

In addition to the 20 gpm diversion to the 30 minute contact tank, a one gpm side stream was diverted to a five minute contact tank. Effluent from the five minute contact tank was passed through a continuous residual analyzer used for dosage control (Advance Series 870 Chlorine Analyzer, modified to read bromine chloride directly). The Wyoming, Michigan study has shown that optimum bromine chloride control was achieved by controlling the residual after 5 minutes contact¹².

The bromine chloride residual was manually maintained at 0.7-1.0 mg/l after 5 minutes contact. Maintaining these residuals was a serious problem during the entire study. The continuous residual analyzer used for dosage control did not retain calibration which necessitated daily calibration and weekly cleaning. Despite these precautions, the

analyzer failed to record all changes in residuals, resulting in poor dosage control and subsequent periods of poor disinfection efficiency.

Problems with the bromine chloride evaporator also resulted in periods of poor disinfection. After 6 weeks the evaporator began to clog with solids buildup within the dip tube, preventing passage of bromine chloride. Visual inspection of the internal chamber and analysis of the solids indicated the cause to be excessive corrosion. The unit had to be rebuilt after feeding 200-300 lbs of bromine chloride. This problem also occurred in a similar study at Wyoming, Michigan.¹²

During the initial portion of the study, the temperature of the liquid bromine chloride in the cylinders was too low to allow gasification at the evaporator temperature (88°C). Additional heat (>100°C) was applied to all external tubing leading from the bromine chloride tanks to the evaporator using heating tapes. With this modification gasification was consistently maintained.

PILOT PLANT EFFLUENT CHARACTERISTICS

The effluents from both disinfection units were monitored daily for biochemical oxygen demand (BOD), suspended solids (SS), ammonia-nitrogen (NH₃-N), nitrate-nitrite nitrogen (NO₃-NO₂-N), total kjeldahl nitrogen (TKN), and total organic carbon (TOC). Monthly averages for these parameters are presented in Tables 2 and 3 for the bromochlorinated and chlorinated effluents, respectively.

TABLE 2

PILOT PLANT BROMINE CHLORIDE EFFLUENT CHARACTERISTICS

<u>Month</u>	<u>Avg. 5 min Residual (mg/l)</u>	<u>BOD₅ (mg/l)</u>	<u>TSS (mg/l)</u>	<u>NO₃-NO₂-N (mg/l)</u>	<u>NH₃-N mg/l)</u>	<u>TKN (mg/l)</u>	<u>TOC (mg/l)</u>
May	0.7	*	*	*	*	*	*
June	0.7	7	12	8.6	3.0	6.5	16.2
July	0.8	6	9	7.7	3.1	5.1	13.0
August	0.7	7	12	2.9	7.9	9.6	13.4

*Analyses not performed.

Table 3

PILOT PLANT CHLORINATED EFFLUENT CHARACTERISTICS

<u>Month</u>	<u>Avg. 30 min Residual (mg/l)</u>	<u>BOD₅ (mg/l)</u>	<u>TSS (mg/l)</u>	<u>NO₃NO₂-N (mg/l)</u>	<u>NH₃-N (mg/l)</u>	<u>TKN (mg/l)</u>	<u>TOC (mg/l)</u>
May	1.3	*	*	*	*	*	*
June	1.4	5	11	8.8	3.0	6.3	16.5
July	1.5	8	8	8.0	3.1	5.1	13.2
August	1.1	4	10	2.8	8.0	8.4	14.6

*Analyses not performed.

Data were also collected on the quantities of each halogen used during the study to provide estimates of the relative chemical costs for each system. Past estimates for bromine chloride indicated that it is approximately twice as expensive as chlorine. Bromine chloride usage must be minimized in order for the system to be cost competitive¹³.

The relative amounts of bromine chloride and chlorine used are presented in Table 4. The corresponding ranges of halogen applied per million gallons treated were 27-51 lb/MG for chlorine and 32-43 lb/MG for bromine chloride. The figures for the chlorination process were within the range at the treatment plant which was 36-76 lb/MG during the same period. The data on chlorine usage from the STP and the pilot plant agreed during the latter half of the experiment. The large discrepancy during the first half of the study can be explained by the difference in residuals maintained between the pilot and the treatment plant. During June 1977, the James River STP lowered its chlorine residual from 1.5-2.5 mg/l to 1.0-2.0 mg/l which more nearly corresponds to the operating level of 1.0 mg/l for the pilot plant.

The figures for bromine chloride usage are deceiving due to the difficulties previously discussed. Although excess bromine chloride was applied during periods of inadequate gasification during the first half of the test, the application rate for bromine chloride was approximately 80-85% of that for chlorine. During the latter half of the test considerable bromine chloride was lost whenever the evaporator was dismantled for cleaning and repair. As a result, bromine chloride usage

TABLE 4: AVERAGE DAILY QUANTITIES OF BROMINE CHLORIDE AND CHLORINE APPLIED

<u>Month</u>	<u>James River STP Cl₂ Applied (lbs/MGal)</u>	<u>Pilot Plant Cl₂ Applied (lbs/MGal)</u>	<u>Pilot Plant BrCl Applied (lbs/MGal)</u>
May	70	51	43
June	76	49	39
July	37	37	43
August	36	27	32

exceeded that for chlorine. No estimates of amount wasted could be made. The data from the first half of the experiment when bromine chloride wastage was minimal, suggest that bromine chloride would be more expensive than chlorine on a chemical basis.

SECTION IV
PILOT PLANT DISINFECTION EFFICIENCIES

INTRODUCTION

Disinfection of sewage treatment plant effluent is necessary for the protection of public health. In order to evaluate the effectiveness of the disinfection process, total and fecal coliform densities have been generally accepted as indicators of the presence or absence of pathogenic microorganisms¹⁴.

The objective of this portion of the study was to evaluate the relative effectiveness of bromine chloride and chlorine in destroying indicator organisms. To achieve this objective, undisinfected James River Sewage Treatment Plant effluent was treated with each halogen and monitored for bacterial densities.

METHODS AND MATERIALS

Effluents from the bromochlorinated and chlorinated streams were sampled four times daily for total and fecal coliforms. The samples were analyzed by the multiple tube fermentation method (MPN)¹⁴. A minimum of three dilutions with five tubes per dilution were tested using Lactose broth (Difco) for the presumptive medium, Brilliant Green Bile broth (Difco) as the confirmatory medium for total coliforms and E. C. broth (Difco) as the confirmatory medium for fecal coliforms.

Samples were taken in sterile jars containing sodium thiosulfate.

The samples were taken from the 30 minute contact tanks at the last access point before discharge.

Analysis for total coliforms was discontinued after July 8, 1977 due to the variability of the total coliform measurement and consequent lack of correlation between the total and fecal coliforms (Table 5).

RESULTS

Disinfection Characteristics

The Commonwealth of Virginia State Water Control Board has issued NPDES permits limiting fecal coliforms in the discharges of secondary treatment plants. These limits are a monthly geometric mean of ≤ 200 fecal coliforms/100 ml and a weekly geometric mean of ≤ 400 fecal coliforms/100 ml. These criteria were used to judge the effectiveness of the disinfection processes.

Analyses of the fecal coliform data generated from the chlorination process were complicated by the low ammonia concentration in the effluent. This condition resulted in periodic breakpoint chlorination with free available chlorine accounting for more than 50 percent of the total residual. During these periods, efficient disinfection was observed at total chlorine residuals of ≤ 0.5 mg/l, confirming the effectiveness of free available chlorine as a disinfectant¹⁵. Breakpoint bromochlorination occurs at much higher ratios of bromine chloride to ammonia and probably occurs less frequently than breakpoint chlorination¹⁶.

TABLE 5

CORRELATION BETWEEN TOTAL AND FECAL COLIFORMS

Chlorine Data

<u>Time (hr.)</u>	<u>Number of Cases</u>	<u>Correlation Coefficient (r²)</u>	<u>P</u>
0001	106	0.36	< 0.001
0600	106	0.50	< 0.001
1200	106	0.68	< 0.001
1600	106	0.61	< 0.001

Bromine Chloride Data

<u>Time (hr.)</u>	<u>Number of Cases</u>	<u>Correlation Coefficient (r²)</u>	<u>P</u>
0001	105	0.15	0.059
0600	105	0.36	< 0.001
1200	105	0.40	< 0.001
1600	105	0.25	0.004

Chlorine + Bromine Chloride Data

<u>Time (hr.)</u>	<u>Number of Cases</u>	<u>Correlation Coefficient (r²)</u>	<u>P</u>
0001	211	0.21	< 0.001
0600	211	0.43	< 0.001
1200	211	0.54	< 0.001
1600	211	0.40	< 0.001

The coliform data obtained from the bromine chloride system were similarly difficult to analyze because of malfunctioning of the residual analyzer and dosing system as previously discussed in Section II.

Both disinfection streams were capable of meeting the 200 fecal coliforms/100 ml limit (Table 6). Chlorine consistently produced monthly geometric means of less than or equal to 16 fecal coliforms per 100 ml with only 6% of all values exceeding 400 fecal coliforms/100 ml at an average 30 minute total chlorine residual of 1.3 mg/l. Bromine chloride produced monthly geometric means of less than or equal to 60 fecal coliforms/100 ml with 15% of all values exceeding 400 fecal coliforms/100 ml at an average 5 minute bromine chloride residual of 0.7 mg/l. Approximately 1/3 of the values for bromine chloride in excess of 400 fecal coliforms per 100 ml are directly associated with dosage problems. The remaining values could not be correlated with any known malfunction, but this does not preclude such a possibility. These results show chlorine to be an efficient wastewater disinfectant. In contrast, bromine chloride was demonstrated to have similar disinfectant qualities but equipment malfunctions caused the bacterial quality of the effluent to be less consistent, resulting in higher monthly means. These results confirm previous studies showing comparable biocidal activity of both halogens 17,18.

Both halogens were capable of reducing total coliforms to monthly geometric means of less than or equal to 1000 coliforms/100 ml in this study. In previous studies at Grandville, Michigan it was not possible

TABLE 6

PILOT PLANT EFFLUENT BACTERIAL DENSITIES

Month	Chlorine System			Bromine Chloride System		
	Avg. 30 min. Chlorine Residual (mg/l)	Fecal Coliforms (#/100 ml)	Total Coliforms (#/100 ml)	Avg. 5 min. BrCl Residual (mg/l)	Fecal Coliforms (#/100/ml)	Total Coliforms (#/100/ml)
May	1.3	16	162	0.7	60	162
June	1.4	10	40	0.7	41	260
July	1.5	5	8*	0.8	50	301*
August	1.1	5	*	0.7	28	*

*Total Coliform Analyses Discontinued after July 8, 1977.

to reduce total coliforms below this level, but the results of the studies at Wyoming, Michigan were in agreement with the James River STP data^{11,12}.

Further analysis of the data was performed to determine the relationship between halogen residual and fecal coliform densities. Because of the wide fluctuations of ammonia in the effluent and its effect on the halogen species, the data were divided into two groups, one for ammonia concentrations less than or equal to 4 mg/l, and the second for ammonia concentrations greater than 4 mg/l. Standard regression analyses were performed for each halogen at both ammonia levels. In each case no significant correlation ($r^2 < 0.11$) existed between residual and fecal coliform densities. However, the data suggested an inverse relationship between the variables, indicating that an increase in residual results in a decrease in fecal coliform densities. Similar results showing this inverse relationship with little statistical correlation between residual and bacterial density were found in the Wyoming, Michigan, studies¹².

Residual Characteristics

In the case of bromine chloride and chlorine the acute toxicity of the effluent streams is generally a function of residual concentration. When treated effluent is chlorinated the residual is comprised of chloramines produced by the reaction of chlorine with ammonia¹⁹. These chloramines are relatively stable compounds which are toxic to aquatic organisms at parts per billion concentrations^{2,3,4}. In order to assess

the relative decay rates of residuals of the two halogens, measurements of residual decay were conducted during normal secondary effluent periods (ammonia present) in addition to periods of sludge bulking and nitrification. Residual decay curves for both halogens are presented in Figures 5-10. While there were insufficient data points to accurately define the curves, the graphs provide insight into the general decay characteristics of both halogen residuals.

In all cases chlorination resulted in the formation of a relatively stable residual after satisfying the initial demand during the first minute of contact (Figures 5, 6, 7). The magnitude of the initial demand was elevated by increased solids or the absence of ammonia in the effluent. Ammonia levels of 0.6 mg/l or a suspended solids concentration of 328 mg/l produced a 50-100 percent increase in initial demand. After the initial demand was satisfied, the residual stabilized for the remaining contact time, generally declining five percent or less. Suspended solids exerted the greatest influence on residual stability and increased the 30 minute decay rate by approximately 10 percent.

Bromine chloride, in contrast, forms less stable bromamines which have higher biocidal activity than chloramines. The variations in initial bromine chloride demand created by changes in solids and ammonia levels were greater than corresponding fluctuations in chlorine demand under similar conditions (Figures 8, 9, 10). Within the 30 minute contact time, the residual decay was 70-100 percent. Using optimum

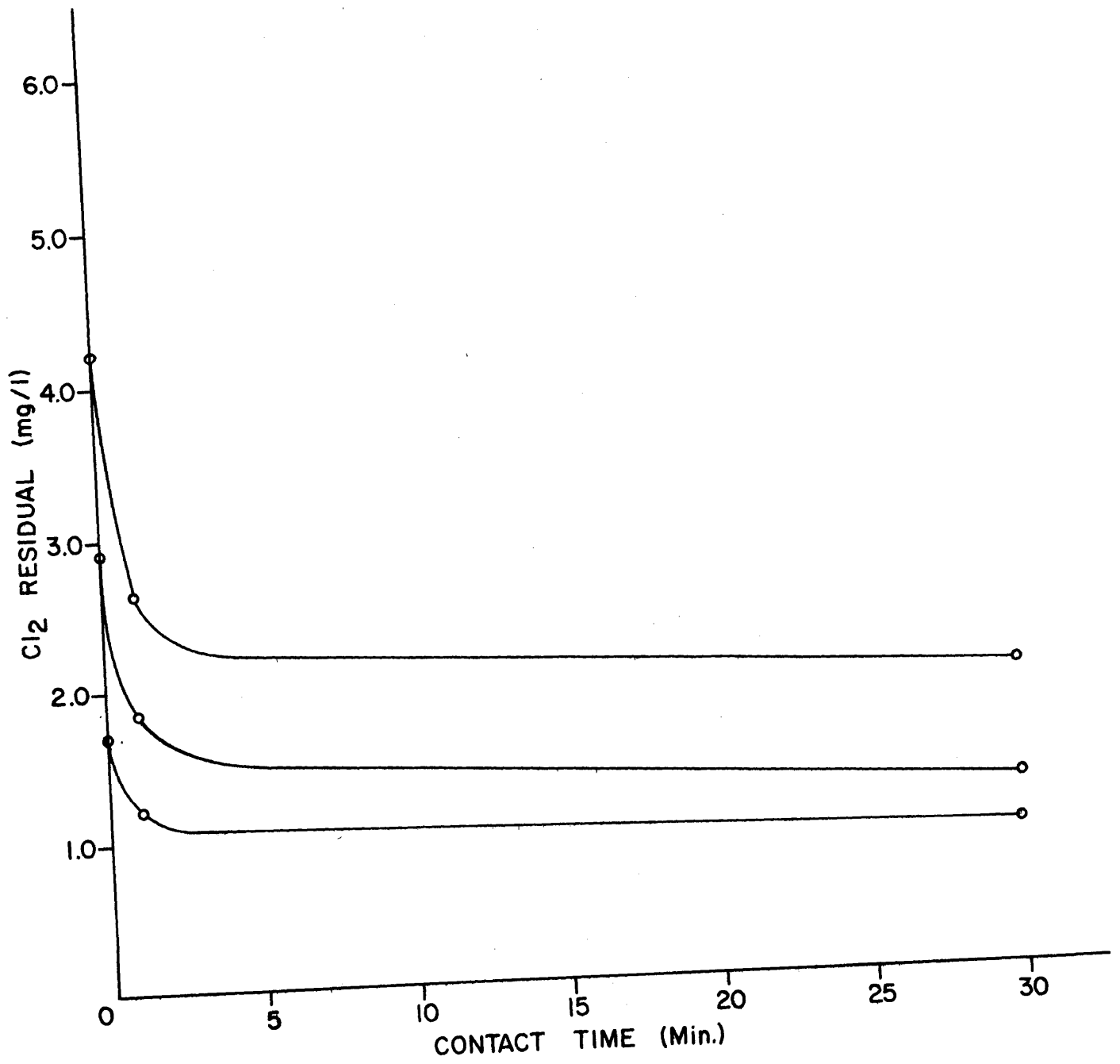

Figure 5 Chlorine Residual Decay For A Suspended Solids Of 7.0mg/l And NH₃-N 12.5 mg/l

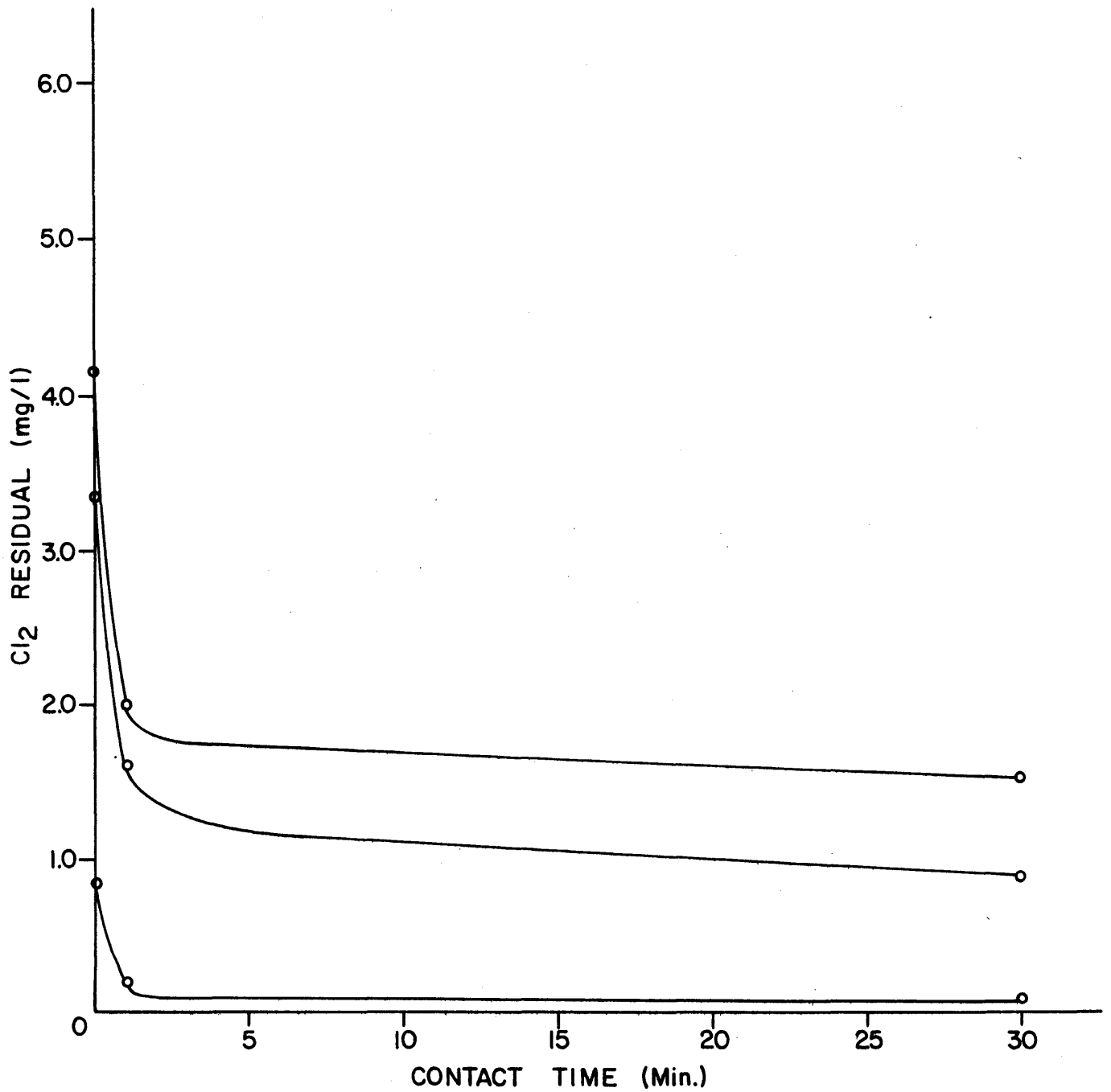

Figure 6 Chlorine Residual Decay For A Suspended Solids Of 6.0mg/l And NH₃-N 0.6 mg/l

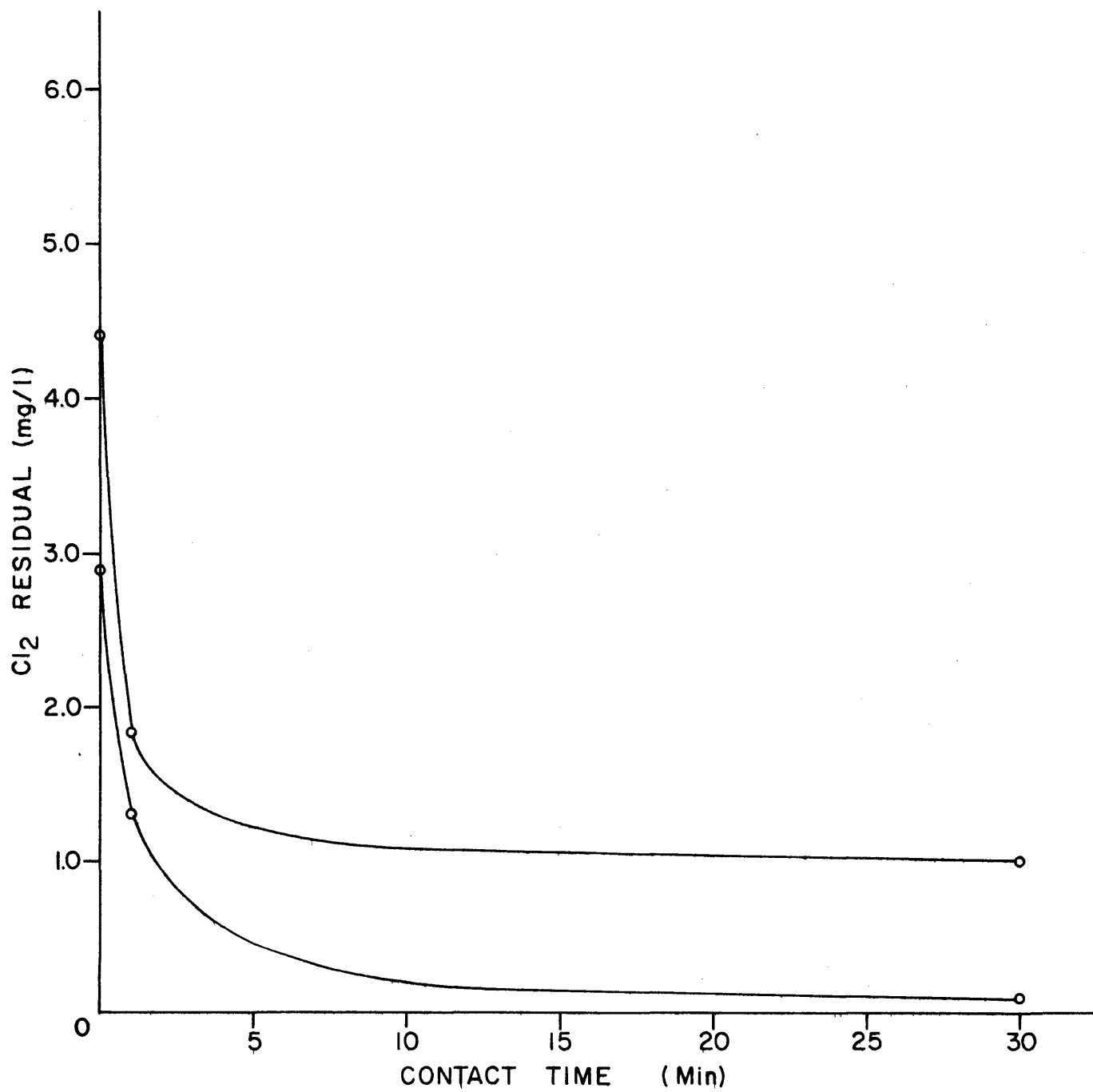

Figure 7

Chlorine Residual Decay For A Suspended Solids Of 328 mg/l And NH₃-N Of 6.2 mg/l.

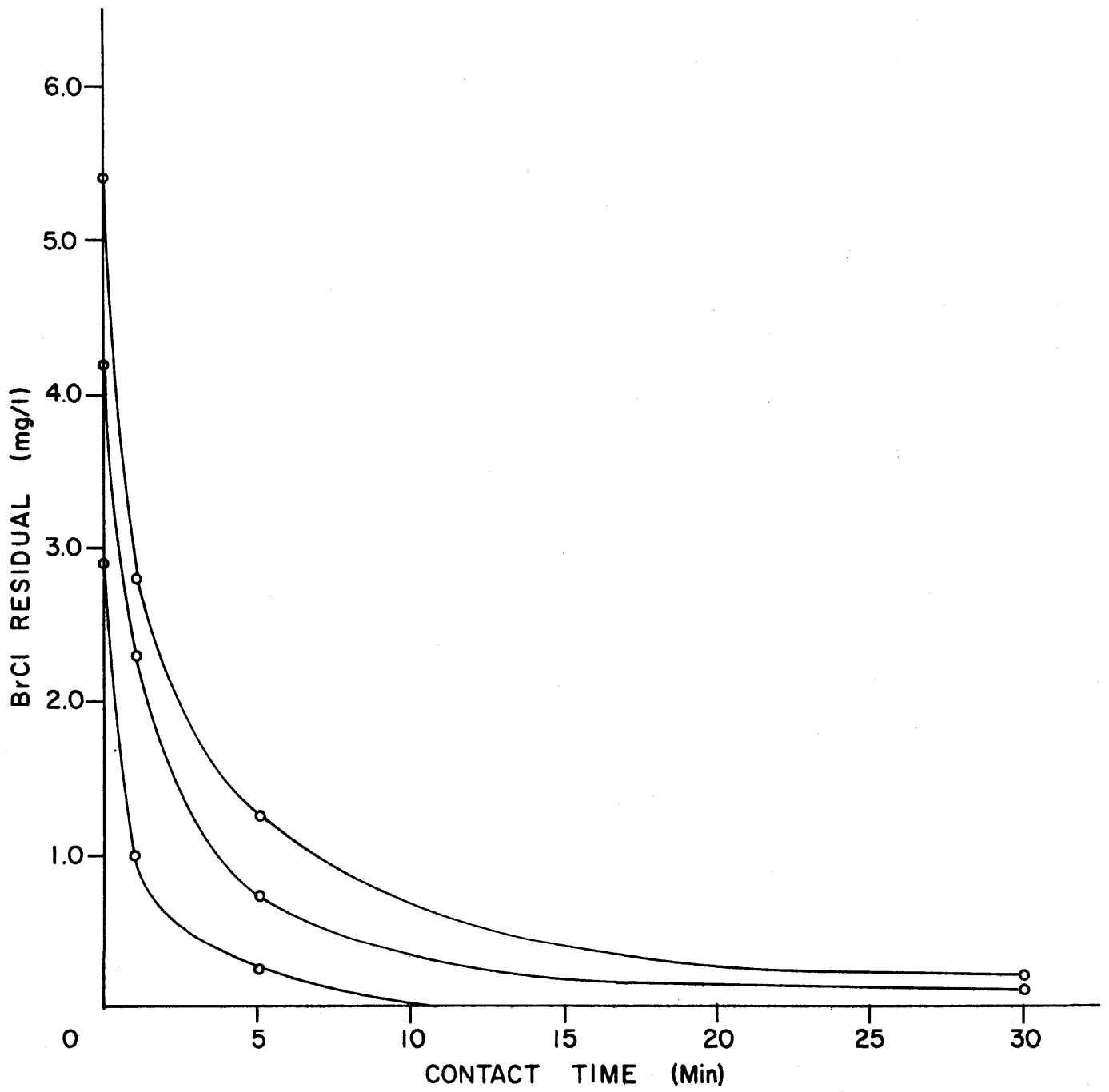

Figure 8 Bromine Chloride Residual Decay For A Suspended Solids Of 7.0 mg/l And NH₃-N 12.5 mg/l

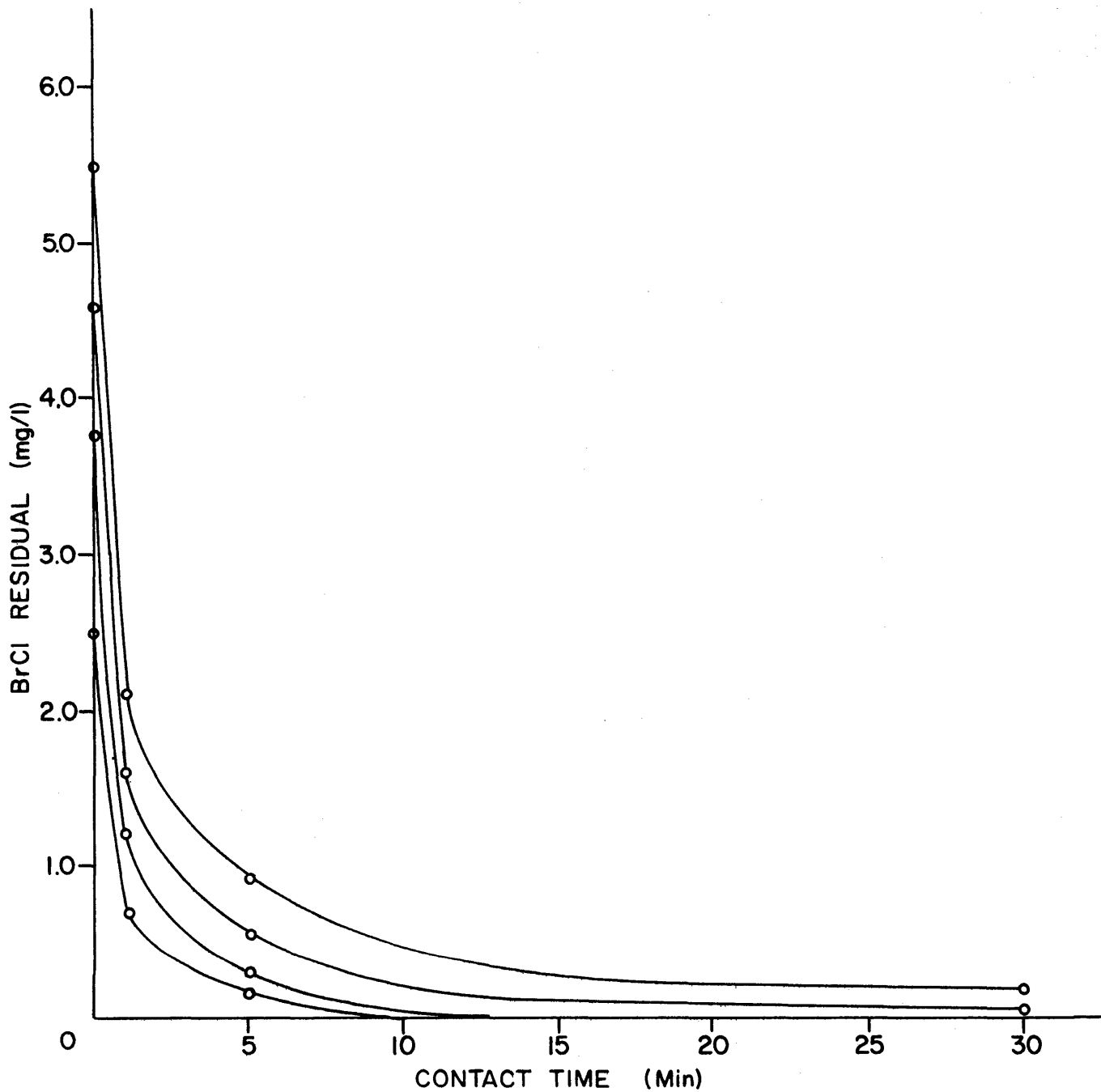

Figure 9 Bromine Chloride Residual Decay For A Suspended Solids Of 6.0 mg/l And $\text{NH}_3\text{-N}$ 0.6 mg/l

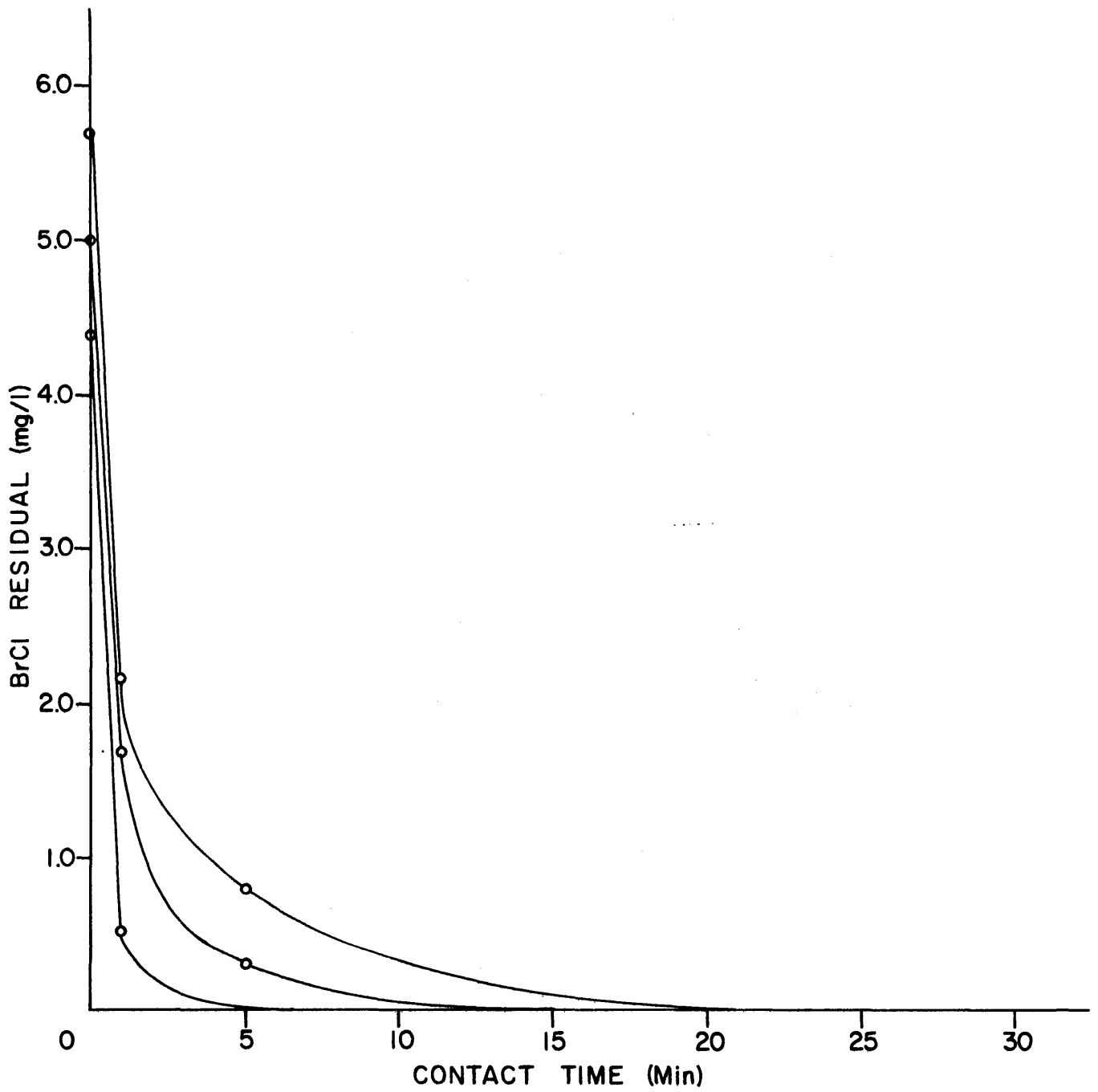

Figure 10 Bromine Chloride Residual Decay For A Suspended Solids Of 328 mg/l And $\text{NH}_3\text{-N}$ Of 6.2 mg/l

residuals for disinfection and normal secondary effluent (containing ammonia), the 30 minute bromine chloride residual is typically less than or equal to 0.1 mg/l, as opposed to a 1.0-2.0 mg/l residual for chlorine.

This reduction in bromine chloride residual has other implications within the treatment plant besides reduced effluent residuals. The contact time needed for bromine chloride may be reduced to approximately one-half that required for chlorine since residual decay indicates that the majority of disinfection is apparently occurring during the first 15 minutes of contact. Subsequently, the bromine chloride residual decreases below an effective biocidal level and excessive algal growth occurs creating mats on the surface of the water. This algal growth impairs the use of disinfected effluent as non-potable water and results in the discharge of increased amounts of suspended solids when using 30 minute contact tanks.

An additional problem associated with the halogenation of algae is the production of trihalomethanes¹. Initial measurements in this study indicate greater trihalomethane production with bromine chloride (10 ppb) than chlorine (3 ppb). These data were obtained from a single grab sample and further work is needed to accurately evaluate the formation and significance of discharges of trihalomethanes in treatment plant effluents.

DISCUSSION

This study has shown comparative disinfection efficiencies for bromine chloride and chlorine. The bromine chloride system was plagued by equipment malfunctions thereby producing disinfected effluent with less consistency than the chlorine system.

The prototype evaporator used in this study was similar to those used currently for chlorination and the information obtained indicates two major problems associated with the use of this type of evaporator for bromine chloride. The material used in construction of the internal heating chamber was easily corroded demonstrating the need to construct this section of the evaporator using an inert metal such as nickel.

In addition, the heating system for the evaporator must be altered to afford higher temperatures and more efficient heat transfer to the liquid bromine chloride. These problems do not appear to be major technological barriers. However, a reliable feed system must be developed for bromine chloride before full scale application.

Instability of the bromamines was again demonstrated in this study. Residuals after 30 minutes contact were approximately an order of magnitude less than those for chlorine. This was also observed by Ward, et al.^{11,12}.

Bromine chloride is approximately twice as costly as chlorine. When compared with chlorination-dechlorination, ozonation with pre-filtration, and ultraviolet radiation with pre-filtration, the cost

of bromine chloride appears to be competitive¹³. The bromine chloride system also offers the advantage of simplicity when compared to the chlorination-dechlorination system while producing effluent of comparable quality and characteristics.

SECTION V
TOXICITY STUDIES

INTRODUCTION

The objectives of this portion of the study were to determine whether the pilot plant effluents diluted to the same extent as the STP effluent entering the river were toxic and to determine what concentration of each halogen in effluent/seawater mixtures produces a 50% kill of ocean spot (Leiostomus xanthurus).

METHODS AND MATERIALS

General

The toxicity studies were performed in a small semi-enclosed temporary building constructed adjacent to the pilot plant. Three waste streams were delivered to header boxes suspended in the toxicity testing facility; an unhalogenated stream, a chlorinated stream and a bromochlorinated stream, each at 1 gpm (3.87 l/min.). The halogenated streams were drawn from the 30-min contact tank effluent streams except as noted below.

Unfiltered James River water was pumped from about 91 m (300 ft) from shore and about 2 m depth (at MLW). The flow was divided between a header box (ca. 5 gpm), and a 3 m (10 ft) diameter fish holding tank (ca. 25 gpm).

Two benches were located in the toxicity testing facility, each capable of holding 14 38-liter (10-gallon) aquaria. A shelf over each table held mixing tanks and the dilutor system.

Office and analytical laboratory activities were located in a small trailer adjacent to the other facilities. Chemical solutions needed for the studies were prepared at the Virginia Institute of Marine Science Laboratory at Gloucester Point, Virginia and transported to the field site.

Dilutor System

The pilot plant was operated at halogenation dosing rates which provided optimal disinfection²⁰ during all but one experiment. In order to avoid differences in salinity among the treatments in the toxicity tests, a fixed sewage-to-estuarine water mixture was employed in most experiments. To provide several halogen dosages and sufficiently high dosages to cause mortality, a dilutor system was used to add the appropriate halogen to aliquots of each waste stream prior to dilution with James River water.

Aliquots of each waste were supplied to mixing tanks by constant-flow siphons. The flow rate was 50 ml/min., which allowed an approximate 15 minute turnover time in the mixing tanks. Stock solutions of the appropriate halogen were pumped into the waste stream as it entered the mixing tanks by means of Harvard peristaltic pumps. Diluent water was provided by constant flow siphons. Initial mixing of

waste and diluent occurred in the overflow tubes of the mixing tanks. The mixtures were delivered to small chambers above the test tanks. The test mixtures passed from these small tanks to the two test aquaria at each dose level through matched constant flow siphons (250 ml/tank/min.).

Stock solutions of chlorine were prepared by diluting appropriate amounts of $\text{Ca}(\text{OCl})_2$ in 18 liters of deionized water. Bromine chloride stock solutions were prepared as described by Roberts and Gleeson²¹. These stock solutions were held in 5 gallon carboys in black plastic bags to prevent sunlight catalyzed reactions. Macalady, Moore and Carpenter²² have demonstrated sun-light catalyzed bromate formation in chlorinated seawater following initial conversion of bromide to hypobromous acid or hypobromite. Bromate formation would have occurred in the bromine chloride stock solutions if they had been exposed to sunlight.

Test Animals

Spot (Leiostomus xanthurus) were selected as the test species because this was a primary species killed in the mass mortalities of 1973, 1974 and 1975 which were attributed to chlorinated sewage entering the James River from the James River Sewage Treatment Plant²³.

Spot were collected from the York River or Mobjack Bay depending on availability, but all fish used in a given experiment were collected at a single location. Fish used during the summer were collected by

seining in Zostera beds. In the fall, fish were collected with a 16 ft. semi-balloon otter trawl in deeper waters.

Fish were removed as rapidly as possible from the nets and placed in 20 gallon ice chests containing water from the sampling site. Water was replenished frequently during the collection period. The collection tank water was aerated during transport in most cases. Fish were transported to the Gloucester Point laboratory where they were held for at least a week in a 1.2 m (4 ft) diameter fiberglass tank receiving unfiltered York River water. Salinity of York River water is generally higher than that of James River water at the sewage treatment plant (20-25 ‰ vs. 12-20 ‰ during the study period). Therefore, one to two days after collection, fresh water (unchlorinated municipal water) was slowly introduced to gradually lower the salinity to that at the James River site. Flake fish food was provided daily. Mortalities during this period were low and restricted to the days immediately following collection.

Following salinity adjustment, the fish were transported to the James River test site in 20 gallon ice chests with continuous aeration. At the test site the fish were held in a 3 m (10 ft) diameter fiberglass tank receiving unfiltered James River water for at least a week prior to testing. Flake fish food was provided daily. Mortalities during this period were negligible.

Experimental Designs

Several experimental designs were used for toxicity tests. The first design was developed to meet the following criteria: 1) no salinity differences between treatments, 2) sewage concentration set at the maximum level actually found at the outfall from the sewage plant (5% sewage), 3) a range of halogen concentrations from a low value which would result from "normal" plant operation (i.e., dilution of sewage dosed to the level required for optimal disinfection) to a high value such as might occur if, for some reason, the plant effluent was overhalogenated. The intent was to test a series of conditions in as "realistic" a fashion as possible. The design developed to meet these criteria is shown in Figure 11 and involves addition of the appropriate halogen to the already halogenated waste at various levels using the dilutor described above. This design was used in the first three experiments.

This experimental design is not necessarily realistic from the standpoint of chemical speciation in the halogenated sewage effluent because the time of injection and the contact time before dilution with receiving water are not comparable with those in actual plant operation. Therefore, a second test design was employed in which the halogen doses in the pilot plant were deliberately increased to the maximum level possible with the equipment. To achieve different residual levels, the superhalogenated effluents were serially diluted to yield effluent/diluent mixtures of 10%, 5%, 2.5%, 1.25%, 0.62% and 0.31%

PILOT PLANT TOXICITY
TEST DESIGN I.

-39-

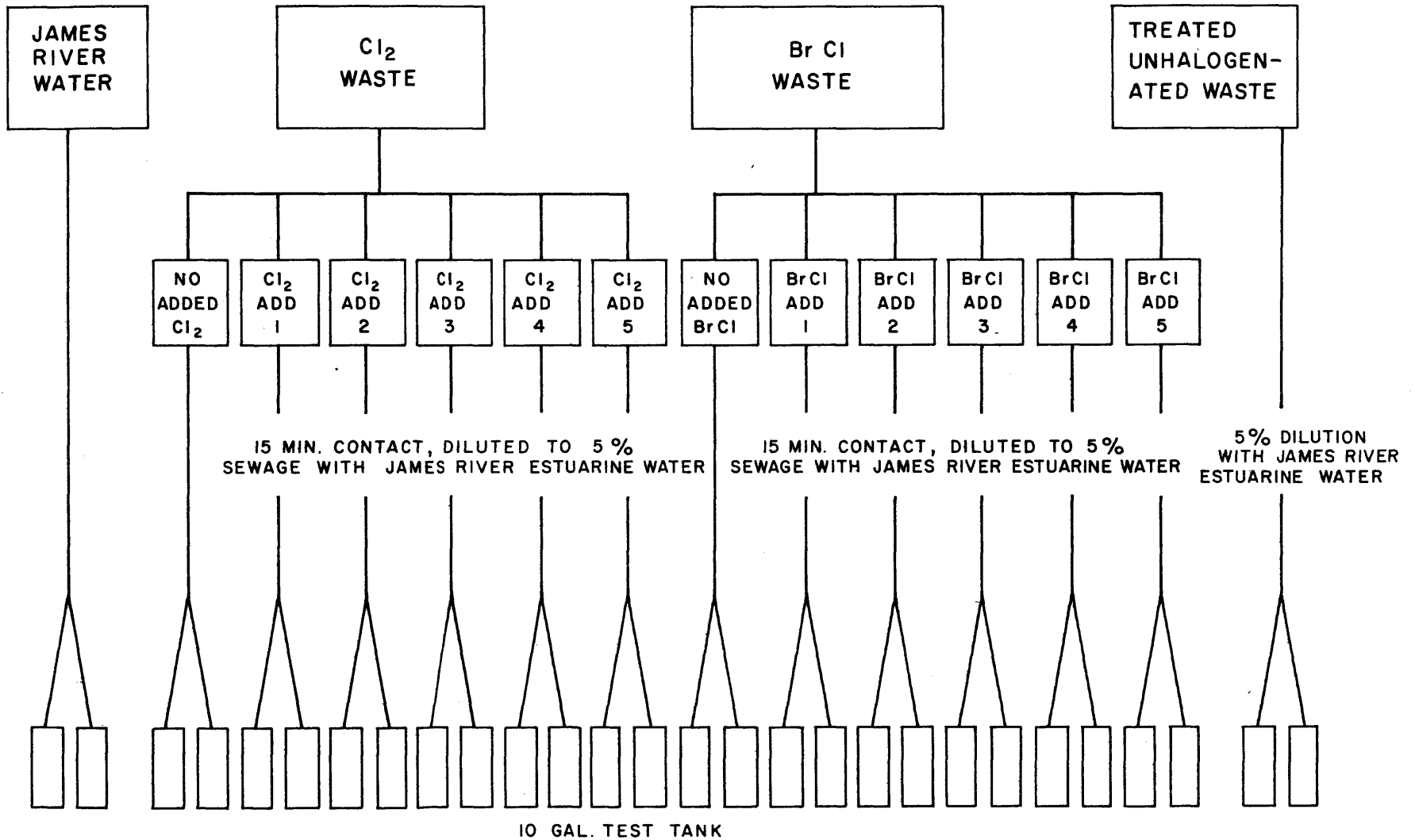

Figure 11. Toxicity test design 1 to assay effects of pilot plant effluents.

sewage effluent (Figure 12). The variation in salinity with this dilution series was negligible. This design was used only once because disinfection studies were obviated by the high halogen doses applied.

A third experimental design used for one test was the same as design 1 except the amount of sewage in the test mixtures was increased to 40%. This was done in an attempt to produce a more stable residual in the test tanks and thereby to increase the residual concentrations.

In each test design, a diluent control was included to ascertain that the diluent water was adequate to support the test fish. This was especially important since the diluent water, of necessity drawn from a site within the field of influence of the plant discharge point, contained a small but measureable chlorine residual. A second control containing unhalogenated clarifier effluent was included to rule out effects from toxic substances possibly present in the sewage effluent itself. In each test, 10 fish were used per tank, or 20 fish per treatment. The fish were fed daily with flake fish food. Excess food was never observed in the tanks.

In all experimental designs, a 10-day exposure was planned, but operational difficulties in the pilot plant, weather effects, availability of halogen stocks, and mechanical failures combined to shorten most experiments.

Environmental Parameters

Temperature, salinity and dissolved oxygen level were determined

PILOT PLANT TOXICITY
TEST DESIGN 2

-14-

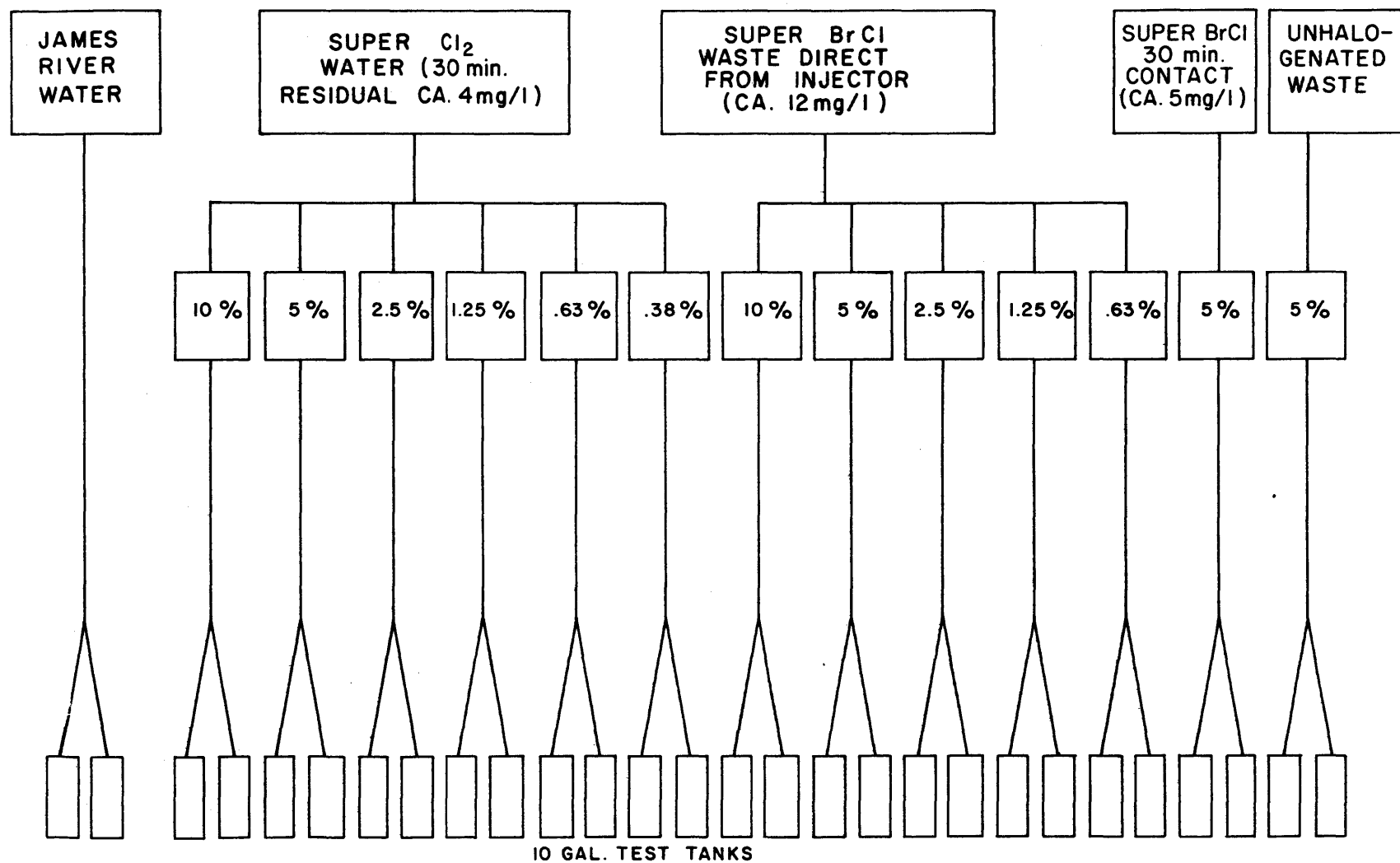

Figure 12. Toxicity test design 2 to assay effects of pilot plant effluents.

daily. Temperature was measured with a stem thermometer. Salinity samples were analyzed with a Bechman RS-7B Salinometer. Dissolved oxygen was analyzed by Winkler titration.

Total halogen residuals were analyzed twice daily on samples from various locations in the dilutor as well as in all test aquaria. Residuals were analyzed by amperometric iodimetric titration using PAO¹⁴ modified by signal amplification to increase sensitivity of the analysis.

Twenty-four hour composite samples of the secondary clarifier effluent were collected and analyzed for various parameters by the Hampton Roads Sanitation District. Selected data from these analyses are presented for each experimental period.

RESULTS

Salinity increased during the study period from 12.7 ‰ in June to ca. 20 ‰ in November. Temperatures followed the typical seasonal pattern from 25.8°C in June to a high of 27.6°C in August, decreasing to 16.8°C in November. Dissolved oxygen concentrations were at or above saturation levels during all experiments.

The chemical characteristics of the secondary clarifier effluent entering the pilot disinfection plant are summarized in Table 7 for each experimental interval. Samples of both effluents from the pilot plant were also analyzed and showed no significant differences from the secondary clarifier effluent. BOD and suspended solids were low in all

TABLE 7

SECONDARY CLARIFIER EFFLUENT QUALITY SHOWING EACH EXPERIMENTAL PERIOD GEOMETRIC MEANS
WERE CALCULATED FROM DAILY VALUES MEASURED ON HOURLY COMPOSITE SAMPLES

Dates		BOD (mg/l)	Suspended Solids (mg/l)	NO ₃ -N (mg/l)	NH ₃ -N (mg/l)	TKN (mg/l)	TOC (mg/l)	Ortho PO ₄ -P (mg/l)	Total PO ₄ -P (mg/l)
21 June -	\bar{x}	7.0	7.4	7.90	4.37	7.35	14.69*	8.27	8.78
30 June	range	4-11	0-16	5.2-11.6	1.8-13.1	3.6-16.3	12.7-15.8	7.0-9.8	7.9-9.9
23 July -	\bar{x}	9.6	8.9	5.92	4.35	5.31	13.18	2.25	2.68
1 August	range	5-17	4-18	4.1-9.6	2.1-6.8	2.2-8.5	9.3-19.6	0.7-6.0	0.8-6.2
13 August -	\bar{x}	19.2	33.7	2.56	6.99	9.08	15.51	1.60	2.83
23 August	range	4-63	4-126	1.3-4.7	3.6-10.9	6.5-15.6	10.6-31.6	0.5-4.3	0.9-6.5
10 Sept. -	\bar{x}	6.0	17.7	5.93	0.88	3.75	13.53	1.83	2.96
20 Sept.	range	2-32	7-115	5.1-7.5	0.4-4.5	2.9-5.6	10.7-31.1	0.7-4.7	2.0-5.6
4 Nov. -	\bar{x}								
11 Nov.	range	NA	NA	NA	NA	NA	NA	NA	NA

* data available only for 21-26 June.

NA - data not available

experiments except number 3. Ammonia-nitrogen levels averaged from 0.88 mg/l in Experiment 4 to 6.99 mg/l in Experiment 3. In all cases, ammonia-nitrogen levels were well below the customary levels for this sewage treatment plant which range from 9 to 15 mg/l (monthly means). Nitrate-nitrogen values were 10 times higher than customary levels. No analyses were made for heavy metals or other potentially toxic substances in the effluent. Since this plant receives only 15% industrial wastes, it should not contain significant levels of toxic substances. Since diluent control and unhalogenated control treatment survival rates were not significantly different in any test, even with mixtures containing 40% sewage, there is no evidence that significant amounts of toxic substances were present in the secondary clarifier effluent.

Experiment 1

During the first experiment (21 to 30 June) the residuals in the effluent from the pilot plant had a geometric mean of 1.45 mg/l for chlorine and 0.72 mg/l for bromine chloride. Effluent residuals during the first 24 hours were markedly higher than for the rest of the test period. Additional halogen was added to these effluents to yield higher simulated effluent residuals. The relationships between effluent residuals in the test aquaria following dilution are shown in Figure 13a. All tank residuals for both halogens were below previously estimated 96 hour LC50 values^{23,21}. Maximum effluent residuals were at levels which might occur in an actual sewage treatment plant. The mean

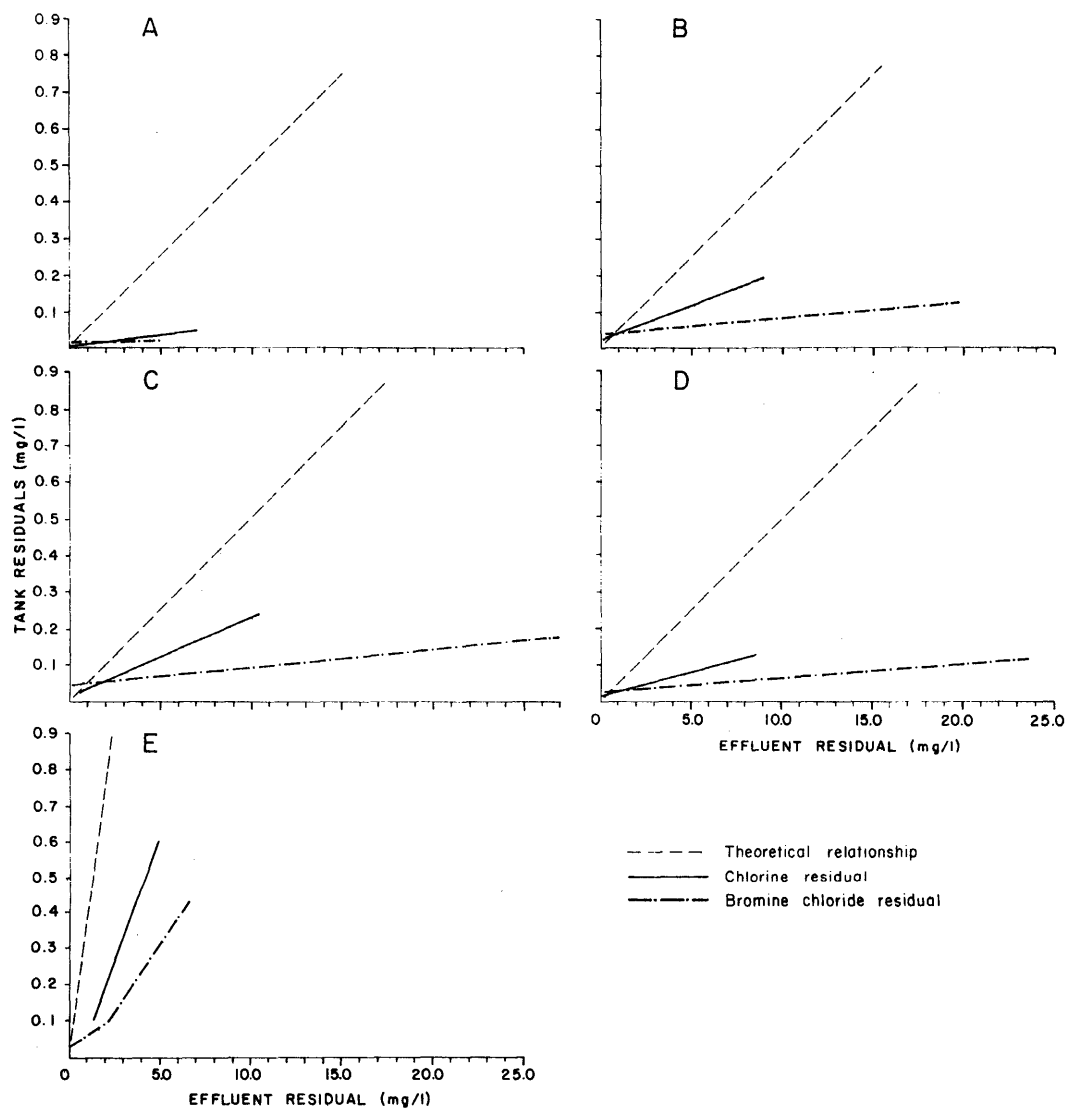

Figure 13. Relationship between simulated effluent residuals and test tank residuals for both halogens. A. Expt. 1; B. Expt. 2; C. Expt. 3 (first half of expt.); D. Expt. 4; E. Expt. 5.

chlorine residual in the diluent water was 0.005 mgCl₂/l (0.008 mg/l expressed as BrCl). The unhalogenated effluent control tanks had an average residual concentration of 0.006 mgCl₂/l.

Fish used in the first experiment averaged 5.64 cm in total length. Survival rates for each treatment are shown in Table 8. There was no significant difference in survival between any test treatment and the control animals based on a X² test.

Experiment 2

In the second experiment (23 July to 1 August) the residuals in the pilot plant effluents averaged 1.0 mg/l for chlorine and 0.65 mg/l for bromine chloride. Higher simulated effluent residual concentrations were tested than in the first experiment. As is shown in Figure 13b, a maximum mean chlorine residual of 0.175 mg/l was achieved in the test tanks while the maximum mean residual for bromine chloride was only 0.125 mg/l. This occurred even though the simulated effluent residual for bromine chloride was over twice that for chlorine. The relationship between effluent residuals and tank residuals was linear as in experiment 1. The mean chlorine residual in the diluent water was 0.03 mg/l (0.05 mg/l expressed as BrCl). At the lowest effluent residual levels and the unhalogenated control treatments, the tank concentrations were approximately equal to the residual in the diluent water. Three chlorinated treatments exceeded the level of 0.09 mg/l Cl₂ reported to be the 96 hour LC50²³. All bromochlorinated treatments were below the 96 hour LC50 value reported for this halogen (0.22 mg/l)²¹.

Table 8

PERCENT SURVIVAL OF SPOT (*Leiostomus xanthurus*)
EXPOSED TO HALOGENATED TREATED SEWAGE EFFLUENTS

Exp. No.	Treatment	Exposure concentration (mg/l) (eq/l)		Days of exposure	Number exposed	Number Surviving	% Surviving
1	Dil.	0.005	0.14	9	22	22	100
	Unhal Ef.	0.006	0.17		21	17	90
	Cl ₂ Ef.	0.004	0.11		19	19	100
	Cl ₂ Ef + Cl	0.014	0.39		19	19	100
		0.018	0.51		20	12	60
		0.021	0.59		17	17	100
		0.038	1.07		24	23	96
		0.044	1.24		20	18	90
	BrCl Ef.	0.011	0.19		27	20	74
	BrCl Ef + BrCl	0.014	0.24		25	25	100
		0.011	0.19		23	21	91
		0.017	0.29		22	17	77
		0.022	0.38		10*	10	100
		0.023	0.40		33	29	88
	2	Dil.	0.03		0.84	9	18
Unhal Ef.		0.02	0.56	12	11		92
Cl ₂ Ef		0.04	1.13	19	17		89
Cl ₂ Ef + Cl		0.06	1.69	20	18		90
		0.06	1.69	18	17		94
		0.11	3.10	21	20		95
		0.12	3.38	9	8		89
		0.18	5.08	24	16		67
BrCl Ef		0.05	0.87	18	17		94
BrCl Ef + BrCl		0.05	0.87	20	16		80
		0.05	0.87	20	14		70
		0.06	1.04	19	16		84
		0.09	1.56	19	17		89
		0.13	2.25	20	19		95
4	Dil.	0.023	0.65	10	19	19	100
	5% Unhal. Eff.	0.011	0.31		19	18	95
	10% Cl ₂ Ef	0.120	3.38		19	14**	74
	5%	0.067	1.89		20	20	100
	2.5%	0.043	1.21		21	21	100
	1.3%	0.024	0.68		20	20	100
	0.6%	0.019	0.54		20	20	100
	0.3%	0.014	0.39		20	20	100

Table 8 (concluded)

PERCENT SURVIVAL OF SPOT (Leiostomus xanthurus)
EXPOSED TO HALOGENATED TREATED SEWAGE EFFLUENTS

Exp. No.	Treatment	Exposure concentration (mg/l)	(eq/l)	Days of exposure	Number exposed	Number Surviving	% Surviving
4	5% BrCl Ef ₃₀	0.048	0.83		17	17	100
	10% BrCl Ef ₀	0.126	2.18		19	19	100
	5	0.069	1.20		20	20	100
	2.5	0.044	0.76		20 ⁺	19	95
	1.3	0.036	0.62		21	21	100
	0.6	0.035	0.61		18	18	100
5	Dil.	0.02	0.56	6	20	20	100
	40% Unhal Ef.	0.02	0.56		20	20	100
	Cl ₂ Ef	0.07	1.97		20	20	100
	Cl ₂ Ef + Cl ₂	0.11	3.10		20	20	100
		0.15	4.23		20	18	90
		0.21	5.92		20	15	75
		0.32	9.02		20	0	0
		0.57	16.07		20	0	0
	BrCl Ef	0.04	0.69		20	20	100
	BrCl Ef + BrCl	0.05	0.87		20	19	95
		0.09	1.56		20	19	95
		0.15	2.60		20	20	100
		0.41	7.11		20	0	0

* 10 fish in one tank died when diluent ceased to flow; not replaced.

** all deaths in one tank

+ 10 fish died in 1 tank for reason(s) unknown; these were replaced by 10 fish which survived for the remaining 6 days.

The test fish in this experiment averaged 8.06 cm in total length, indicating growth in the wild population since experiment 1. The survival of fish in this test is summarized in Table 8. No mortalities attributable to exposure to either halogen were observed, despite the fact that chlorine residuals in three chlorinated treatments exceeded the reported 96 hour LC50.

Experiment 3

Although stock solutions in experiment 3 were more concentrated than those in experiment 2, the simulated effluent residuals were not increased during the first part of the experiment (Figure 13c). After 4 days, the stock flow rate was increased from 1 ml/min to 3 ml/min in an attempt to increase simulated effluent and tank residuals. During the final 5 days of the experiment, tank residual levels averaged higher than before, but were very erratic over time making interpretation of mortality data very uncertain (see below). Stock solutions were depleted on day 9 forcing termination of the test.

The relationships between effluent residual concentrations and tank residuals during the early part of the test were linear for both halogens just as in previous experiments. During the latter half of the experiment, the tank residuals/effluent concentration curve for chlorine was curvilinear leveling out at about 0.05 mg/l at high effluent concentrations, whereas for bromine chloride, the tank residuals bore a linear relationship to effluent concentrations to a tank residual of 1.31 mg/l (not figured). It must be kept in mind, however, that the

daily residual levels varied widely so that the relationship between mean residuals may be spurious.

Throughout the experiment, the diluent water had a mean chlorine residual of 0.03 mg/l (0.05 mg/l expressed as bromine chloride). The unhalogenated waste control had a mean residual of 0.02 mg/l. The residual concentrations of these controls are not significantly different.

The fish used in this experiment averaged 8.96 cm in total length. During the first 4 days of the test, no halogen related deaths occurred even though the maximum tank residual for chlorine (0.208 mg/l) was over twice the reported 96 hour LC50²³, and the maximum tank residual for bromine chloride (0.183 mg/l) was close to the previously determined 96 hour LC50²¹.

In the second half of the experiment, mortalities were observed after brief exposures (24 to 48 hours) to high doses of both halogens. The variability in test concentrations over time prevent a statistical evaluation of the dose-mortality relationship. An attempt to evaluate these results was made by plotting the mean survival for each 24 hour period against the log mean concentration for the period (Figure 14a). A similar figure was prepared for each 48 hour interval (Figure 14b). From these figures, it would appear that the 24 hour LC50's for both halogens lie between 0.42 and 0.50 mg/l while the 48 hour LC50's lie between 0.30 and 0.45 mg/l. Since no significant mortalities were observed over periods greater than 96 hour at doses of 0.19 mgCl₂/l or

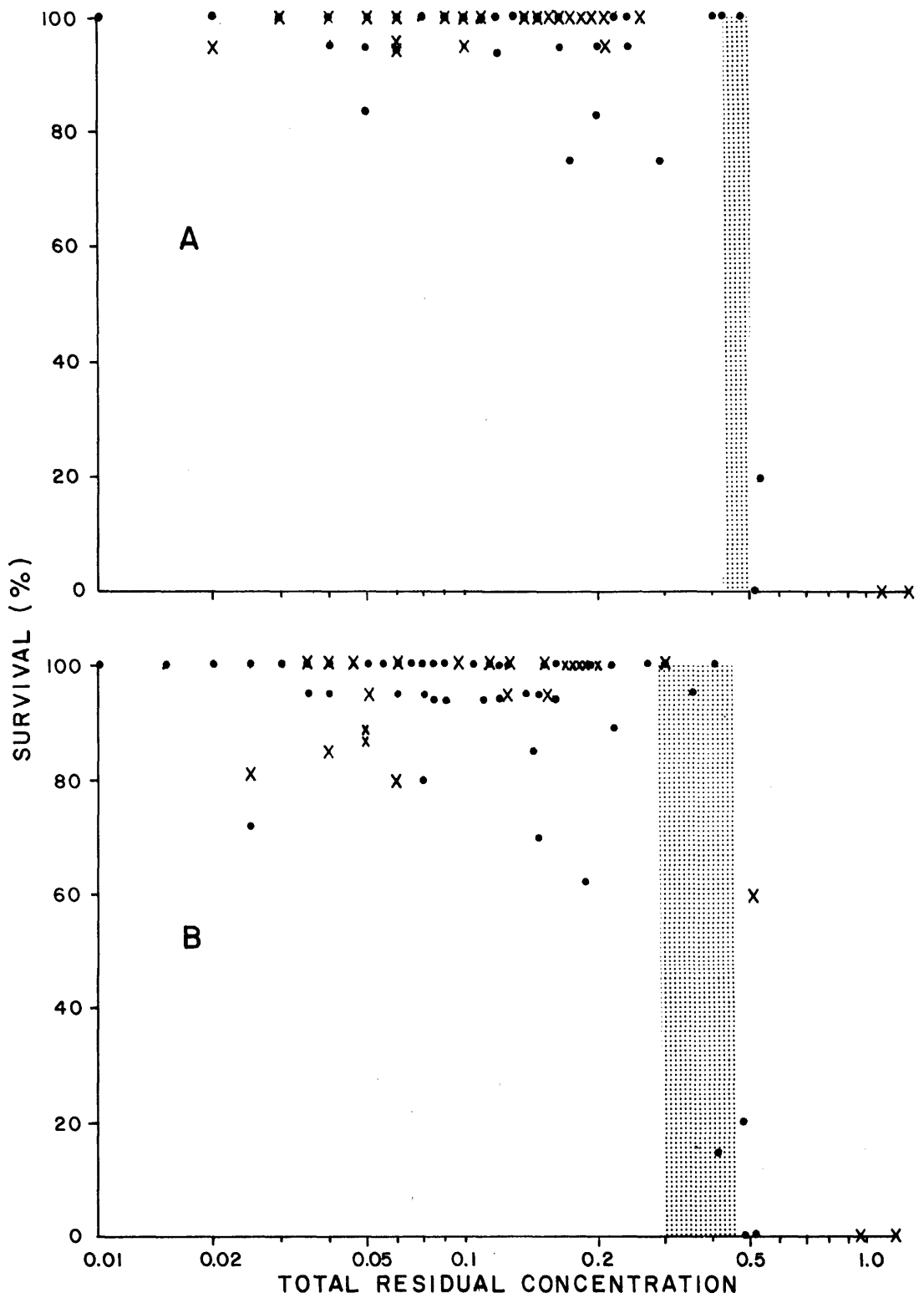

Figure 14. Survival rates for juvenile Leioostomus xanthurus during Experiment 3 as a function of total halogen residual. Shaded areas indicate the concentration range within which the LC50 falls. {.} represent values for chlorine, {x} represent values for bromine chloride. A. 24 hr interval data. B. 48 hr interval data.

0.20 mgBrCl/l, the 96 hour LC50's must lie between 0.20 and 0.30 mg/l.

Experiment 4

This test was designed to evaluate the effect of a "worst case" situation in which the disinfectant injectors operated at the maximum injection rate possible with the equipment. Therefore, the chlorine injector in the pilot plant was adjusted to 10 lb/day (4.5 kg/day) and the bromine chloride injector to 25 lb/day (11.3 kg/day). The resultant effluent residuals were 4.13 mg/l for chlorine after 30 minute contact, 11.45 mg/l and 5.17 mg/l for bromine chloride after 0 and 30 minutes, respectively (the 0 minute effluent was drawn immediately after the injector). The chlorinated effluent, serially diluted with estuarine water to produce test solutions containing 10, 5, 2.5, 1.3, 0.6, and 0.4 percent sewage, yielded average tank residuals of 0.12, 0.067, 0.043, 0.024, 0.019, and 0.014 mgCl₂/l, respectively. The 30 minute bromochlorinated effluent mixed with river water to produce a solution containing 5 percent sewage had a tank residual of 0.048 mgBrCl/l. Bromochlorinated effluent drawn off immediately after the injector and serially diluted to produce mixtures containing 10, 5, 2.5, 1.3 and 0.6 percent sewage, had tank residuals of 0.126, 0.069, 0.044, 0.036, and 0.035 mgBrCl/l, respectively (Figure 13d). Again, none of these residual concentrations were high enough to cause mortalities based on earlier results^{23,21}. The residuals for diluent control and unhalogenated waste control were 0.02 and 0.01 mg/l, respectively.

The fish used in this experiment averaged 9.47 cm in total length.

Five of nineteen fish died at the highest chlorine dose during the 10-day test, but this was not significantly more than in the diluent or effluent control groups based on a X^2 test. No other treatment had more than one fish dead after 10 days exposure (Table 8).

Experiment 5

Since lethal conditions could not be achieved even with superhalogenated effluents from the pilot plant, it was decided in consultation with the technical committee of the Virginia Interagency Task Force on Chlorine and their consultants to increase the percentage of effluent in the test mixtures to 40% with the plant operating at optimal halogenation levels. The dilutor was again employed to simulate higher halogen residuals in the effluent. Spot is a broadly euryhaline species tolerating salinities in the laboratory as low as 0 ‰^{24,25}. The salinity of the diluent water control during this experiment was approximately 20‰. All other treatments were diluted to a final mixture of 40% sewage effluent (0 ‰ salinity): 60% estuarine water (20 ‰ salinity). Thus, the salinity in these tanks is estimated to have been 12 ‰, well within the tolerance limits for this species. There was no difference in survival between the diluent control animals (at 20 ‰) and the halogenated effluent control animals (at 12 ‰) indicating no measurable salinity effect in this experiment.

With this design, consistently high halogen residuals in the test aquaria were achieved (Figure 13e). The relationship between effluent residuals and tank residuals for both halogens were linear except at

lower levels of bromine chloride which approximated the diluent water residual (expressed as bromine chloride). Tank residuals ranged from 0.11 to 0.57 mg/l for chlorine and from 0.04 to 0.41 mg/l for bromine chloride. For any given effluent residual, the chlorine tank residual was approximately twice the bromine chloride residual except at the lowest bromine chloride doses.

The experiment was terminated after 6 days because of weather-induced malfunctions of the test systems. Heavy rains and consequent excessive flows in the treatment plant resulted in a high solids level in the pilot plant effluent. The high solids level disrupted effluent flow to the dilutor. Further, suspended solids levels in the river were also elevated by storm runoff and high winds causing a reduction in diluent flow. These factors led to over-dosing after day 6 since stock halogen solutions continued to be delivered to the dilutor and thence to the test aquaria.

The fish used in this experiment averaged 10.54 cm in length. Dose related mortalities were observed in this experiment but no mortalities were observed in the diluent or 40% effluent control populations (Table 8). Based on the observed mortalities, 24, 48, 96, and 144 hr LC50's were estimated for each halogen. These values are summarized in Table 9. The values all fall within the concentration ranges suggested by Experiment 3. Virtually all mortality is apparently completed after 96 hours as can be seen from the LC50 values for 144 hours.

Table 9

SUMMARY OF LC50 VALUES* FOR EACH HALOGEN AS DETERMINED
 IN EXPERIMENT 5 WITH NH₃-N LEVELS AMBIENT IN
 CLARIFIER EFFLUENT

Time	LC50's	
	mg/l Cl ₂	mg/l BrCl
24 hr.	0.48 (0.37-0.63)	>0.41
48 hr.	0.31 (0.25-0.38)	0.38
96 hr.	0.23 (0.21-0.24)	0.25
144 hr.	0.23-(0.21-0.25)	0.25

* Chlorine LC50 values calculated by graphical probit method²⁶. Bromine chloride 24 hour LC50 value exceeded maximum dose tested; 48 hour LC50 estimated from probit/log plot, but confidence intervals could not be calculated; 96 and 144 hour LC50's estimated as square root of product of doses causing 0 and 100% mortality²⁷.

DISCUSSION

Throughout the study period, the diluent water derived from the James River contained a small amount of oxidant measurable by PAO titration. There was a mean apparent residual in the unhalogenated waste test tanks approximately equal to that in the diluent water (within experimental error). On a few occasions in the first experiment, the unhalogenated waste had a higher residual level than the diluent water resulting from backflow in the pilot plant. This problem was corrected by readjusting pilot plant flow and was not a problem in later tests.

There was a linear relationship between simulated effluent residual levels and tank residual levels. The residuals were always markedly less than the concentrations predicted from the dilution factor, indicating that the residuals are unstable in receiving waters as is well known. In every case, bromine chloride residuals decayed more rapidly than chlorine residuals as suggested by Mills¹⁷.

The slopes for the simulated effluent residuals versus tank residuals were calculated and compared to the sewage ammonia-nitrogen concentration for each experiment; no relationship was observed. One might expect that chlorinated sewage effluent would contain largely monochloramine which is relatively stable, whereas bromochlorinated sewage would contain less stable bromamines. In this study, however, little ammonia was present. In analyses of chlorinated effluent from this sewage treatment plant, made in conjunction with another project,

little "monochloramine" was ever detected. Ammonia-nitrogen level in the effluent, by itself, does not therefore explain the different stability for chlorine vs. bromine chloride in the estuarine water.

The percent loss of each halogen after adjustment of tank residuals for diluent residual was calculated for each experiment as

$$\% \text{ loss} = \frac{S_t - S_m}{S_t} \times 100$$

where S_t = theoretic slope of tank residual versus effluent residual (i.e., dilution factor)

S_m = measured slope of tank residual versus effluent residual

In essence, this calculation yields an estimate of percent loss with reduced bias from analytical and sampling errors and statistically adjusted for the background residual. The loss of BrCl residuals ranged from 84-94% and there was no correlation between percent loss of residual and sewage ammonia-nitrogen level or the percentage of sewage in the effluent-diluent mixtures. For chlorine, the loss or residual varied from 58 to 86% with no correlation between percent loss of residual and sewage ammonia-nitrogen level or the percentage of sewage in the effluent-diluent mixtures.

The 96-hour LC50 value for chlorine of 0.23 mg/l obtained in this study do not agree with the value 0.09 mg/l reported by Bellanca and Bailey²³ or the value of 0.065 mg/l (at 15°C) reported by Middaugh et al²⁸. The reason for the lack of agreement is not readily apparent; the

fish used by Middaugh et al were smaller than in the present study, but the test temperature was lower. If the cause was the presence of sewage in the present test but not the tests of Bellanca and Bailey²³ and Middaugh et al.²⁸, then the data of Liden and Burton²⁹ obtained in a power plant study would have agreed with the laboratory studies. Yet Liden and Burton observed no deaths attributable to chlorine at concentrations up to 0.06 mg/l (reported as 0.085 mg/l in Bongers et al.³⁰, around the reported 96-hour LC50's, even after 20 days. Rather, Liden and Burton's data compare favorably with the results of the present study. Therefore, there is no indication that the differences between the LC50 values result from the presence of sewage. Further, the LC50 values were unaffected by the amount of sewage in the test mixtures (comparing experiments 3 and 5) which again excludes the presence of sewage as the critical factor.

The 96 hour LC50 for bromine chloride in the present study (0.25 mg/l) compares favorably with the value (0.22 mg/l) reported by Roberts and Gleeson²¹ in a laboratory study. This is true even though in the present study, bromate (not measured by PAO titration at pH4) may have been formed by exposure to sunlight (Macalady et al.²²). Macalady raised the question of the toxicity of bromate. Liden and Burton²⁹ reported no significant mortality of spot exposed to 0.081 mg/l (reported as 0.086 mg/l in Bongers et al.³⁰) after 20 days. This result agrees with the data reported herein.

The agreement between the LC50 values for bromine chloride and the

lack of any evidence that the LC50 of chlorine or bromine chloride is affected by either ammonia-nitrogen concentration or the amount of sewage in the test mixture imply that the halogen residual per se is the lethal constituent.

It is surprising, in light of previous work showing chlorine to be more toxic than bromine chloride on either a weight or an equivalent basis²¹, that the LC50's for both halogens were the same on a weight basis in the present study. On an equivalent basis, bromine chloride would then be more toxic than chlorine. No explanation of this conflicting observation can presently be suggested. The continuing need to understand the chemical speciation in the test solutions to properly interpret the toxicity results is again underscored^{21,22}.

The residual concentrations produced in the present study under realistic conditions of plant operation (5% sewage in the effluent/seawater mixture and halogenation rates from the disinfection optima to the maximum rates possible with injection equipment) were not high enough to kill spot. However, the higher test concentrations were in the range known to kill oyster larvae and copepods²¹. When the percentage of sewage was increased in the effluent/seawater mixture (with the chlorination rate at optimal disinfection levels), concentrations lethal to spot could be achieved.

SECTION VI

REFERENCES

1. Environmental Protection Agency, 1976. Disinfection of Wastewater - Task Force Report. Office of Research and Development. EPA - 430/9-75-012, U.S. EPA Washington, D.C., 45 pp.
2. Bender, M.E., M.H. Roberts, R.J. Diaz, and R.J. Huggett, 1977. Effects of Residual Chlorine in Estuarine Organisms. pp. 86-164. In: L.D. Jensen (ed.). Biofouling Control Procedures; Technology and Ecological Effects. Pollution Engineering and Technology, Vol. 5, Marcel Dekker, Inc., New York.
3. Brungs, W.A., 1973. Effects of Residual Chlorine on Aquatic Life. J. Water Poll. Con. Fed. 45:2180-2193.
4. Brungs, W.A., 1976 Effects of Wastewater and Cooling Water Chlorination on Aquatic Life. Ecological Research Series, EPA-600/3-76-078, U.S. EPA, Duluth, Minnesota., 45 pages.
5. Carlson, R.M. and R. Caple. 1976. Organo-Chemical Implications of Water Chlorination. p. 73-84. In: R.L. Jolley (ed.), The Environmental Impact of Water Chlorination. Oak Ridge National Laboratory, Oak Ridge, Tennessee. CONF - 751096.
6. Glaze, W.A., J.E. Henderson, and J. Smith, 1976. Analyses of New Chlorinated Organic Compounds Formed by Chlorination of Municipal Wastewater. p. 173-176. In: R.L. Jolley (ed.), The Environmental

Impact of Water Chlorination. Oak Ridge National Laboratory, Oak Ridge, Tennessee. CONF - 751096.

7. Eschenbrenner, A.B. and E. Miller. 1945. Induction of hepatomas in mice by repeated oral administration of chloroform with observations on sex differences. J. Nat. Cancer Inst. 5:251.
8. Christensen, H.R., T.T. Luginbyhl and B.S. Carroll. 1975. Registry of Toxic Effects of Chemical Substances, 1975 Edition. U.S. HEW, Rockville, Maryland, U.S. GPO 1975-657-696/5505, 1296 pp.
9. Kraybill, H.F. 1976. Origin, classification and distribution of chemicals in drinking water with an assessment of their carcinogenic potential. pp. 229-246. In: R.L. Jolley (ed.) The Environmental Impact of Water Chlorination. Oak Ridge National Laboratory, Oak Ridge, Tennessee, CONF-751096.
10. Tardiff, R.G., G.P. Carlson, and V. Simmon. 1976. Halogenated organics in tap water: A toxicological evaluation. pp. 213-227. In: R.L. Jolley (ed.) The Environmental Impact of Water Chlorination. Oak Ridge National Laboratory, Oak Ridge, Tennessee, CONF-751096.
11. Ward, R.W., R.D. Giffin, G.M. DeGraeve and R.A. Stone. 1976. Disinfection Efficiency and Residual Toxicity of Several Wastewater Disinfectants. Vol. I. Grandville, Michigan. Environmental Protection Technology Series, EPA-600/2-76-156, U.S. EPA, Cincinnati, Ohio, 132 pp.

12. Ward, R.W., R.D. Giffin, and G.W. DeGraeve, 1977. Disinfection Efficiency and Residual Toxicity of Several Wastewater Disinfectants. Vol. II - Wyoming, Michigan, Environmental Protection Technology Series, EPA-600/2-77-203, U.S. EPA, Cincinnati, Ohio, 107 pp.
13. Sawyer, C.M., 1976. Wastewater Disinfection - A State-of-the Art Summary, Water Resources Research Center, Bull. 89, Virginia Polytechnic Institute, 106 pp.
14. APHA, 1976. Standard Methods for the Examination of Water and Wastewater, 14th Edition, Am. Pub. Health Assoc., Washington, D.C., 1193 pp.
15. White, G.D. 1976. Current Chlorination and Dechlorination Practices in the Treatment of Potable Water, Wastewater, and Cooling Water. pp. 7-24. In: R.L. Jolley (ed.). The Environmental Impact of Water Chlorination. Oak Ridge National Laboratory, Oak Ridge, Tennessee, CONF - 751096.
16. LaPoint, T.F., G. Imman, and J.D. Johnson. 1975. Kinetics of Tribromamine Decomposition. pp. 301-338. In: J.D. Johnson (ed.), Disinfection - Water and Wastewater. Ann Arbor Science Publishers, Inc., Ann Arbor, Michigan.
17. Mills, J.F. 1975. Interhalogens and Halogen Mixtures as Disinfectants. pp. 113-143. In: J.D. Johnson (ed.), Disinfection - Water and Wastewater, Ann Arbor Science Publishers, Inc., Ann

Arbor, Michigan.

18. Stringer, R.P., W.N. Cramer, and C.W. Kruse. 1975. Comparison of Bromine, Chlorine, and Iodine as Disinfectants for Amoebic Cysts. pp. 193-210. In: J.D. Johnson (ed.), Disinfection - Water and Wastewater, Ann Arbor Science Publishers, Inc., Ann Arbor, Michigan.
19. Saunier, B., and Selleck, R.E., 1976. Kinetics of Breakpoint Chlorination and of Disinfection, Sanitary Engineering Res. Lab, U.S. Berkeley, SERL Report No. 76-2, 137 pp.
20. LeBlanc, N.E., and J.M. McEuen. 1978. A Comparison of Bromine Chloride and Chlorine as Wastewater Disinfectants. pp. 637-650. In: R.L. Jolley (ed.) Proceedings of the Second Conference on the Environmental Impact of Water Chlorination, Ann Arbor Science Publishers, Inc., Ann Arbor, Michigan.
21. Roberts, M.H., Jr., and R.H. Gleeson. 1978. Acute Toxicity of Bromochlorinated Seawater to Selected Estuarine Species with a Comparison to Chlorinated Seawater Toxicity. Mar. Environ. Res. (in press).
22. Macalady, D.L., J.H. Carpenter, and C.A. Moore. 1977. Sunlight-induced Bromate Formation in Chlorinated Seawater. Science 195:1335-1337.

23. Bellanca, M.A. and D.S. Bailey. 1977. Effects of Chlorinated Effluents on the Aquatic Ecosystems of the Lower James River. J. Water Poll. Cont. Fed. 49:639-645.
24. Massman, W.H. 1954. Marine Fishes in Fresh and Brackish Waters of Virginia Rivers. Ecology 35:75-78.
25. Music, J.L., Jr. 1974. Observations on the Spot (Leiostomus xanthurus) in Georgia's Estuarine and Close Inshore Ocean Waters. Ga. Dept. Nat. Res., Contri. Ser. No. 28, 29 pp.
26. Litchfield, J.R., Jr. and F. Wilcoxon. 1949. A Simplified Method of Evaluating Dose-effect Experiments. J. Pharmacol. Expt. Therap. 96:99-113.
27. Stephan, C.E. 1977. Methods of Calculating an LC50. pp. 65-84. In: F.L. Mayer and J.L. Hamelink (ed.) Aquatic Toxicology and Hazard Evaluation. ASTM Spec. Tech. Publ. 634.
28. Middaugh, D.P., A.M. Crane, and J.A. Couch. 1977. Toxicity of Chlorine to Juvenile Spot, Leiostomus xanthurus. Water Res. 11:1089-1096.
29. Liden, L.H. and D.R. Burton. 1977. Survival of Juvenile Atlantic Menhaden (Brevoortia tyrannus) and Spot (Leiostomus xanthurus) to Bromine Chloride and Chlorine Treated Estuarine Waters. J. Environ. Science Health A12:375-388.
30. Bongers, L.H., B. Bradley, D.T. Burton, A.F. Holland, and L.H.

Liden. 1977. Biototoxicity of Bromine Chloride - and
Chlorine-treated Power Plant Condenser Cooling Water Effluent.
Martin Marietta Environmental Technology Center, Report to Ethyl
Corporation and Great Lakes Chemical Corp., 61 pp.

