

**Laser *In-situ* Scattering and Transmissometer (LISST)  
Observations in Support of the Sensor Insertion System  
Duck, NC  
October, 1997**

Grace M. Battisto and Carl T. Friedrichs

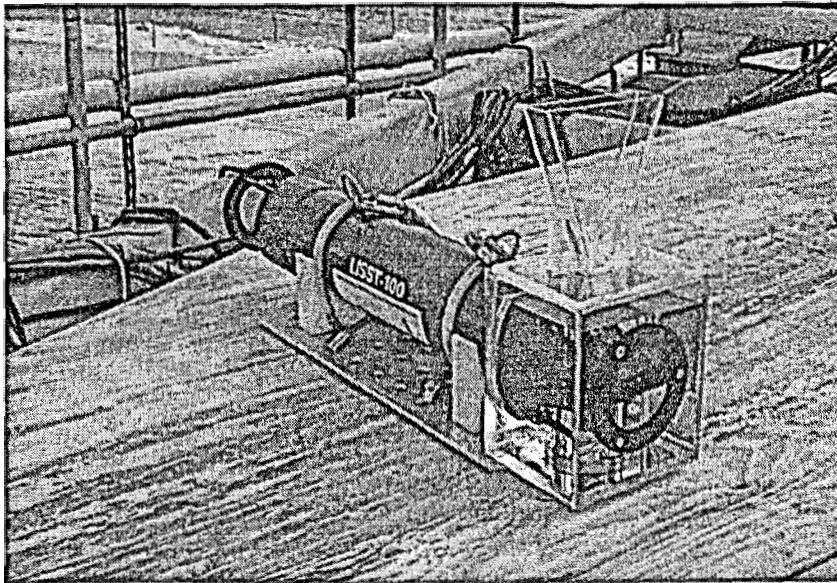

VIMS Data Report Number 57

School of Marine Science  
College of William and Mary  
Gloucester Point, VA 23062

November 1998

Research sponsored by the U.S. Army of Corps of Engineers, Waterways Experiment Station,  
Contract DACW39-98-K-0035, and by the National Science Foundation, Ocean Sciences  
Division Grant OCE-9504198

Laser *In-situ* Scattering and Transmissometry (LISST) Observations  
in Support of the Sensor Insertion System, Duck, N.C., October, 1997

Grace M. Battisto  
Carl T. Friedrichs

VIMS Data Report Number 57

School of Marine Science  
Virginia Institute of Marine Science  
College of William and Mary  
Gloucester Point, VA 23062

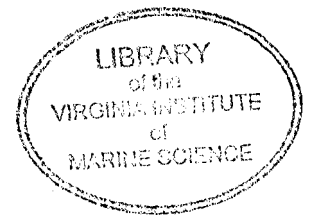

November 1998

Research sponsored by the U.S. Army Corps of Engineers, Waterways Experiment Station,  
Contract DACW39-98-K-0035, and by the National Science Foundation, Ocean Sciences  
Division Grant OCE-9504198

## 1. Introduction

In October 1997, a group of scientists and graduate students coordinated by Grace Battisto of the Virginia Institute of Marine Science (VIMS) collected particle size distribution time series of suspended sediment utilizing the Laser *in-situ* Scattering Transmissometer (LISST) at various stations across the surf zone. The time series were collected at the same time as pumped suspended samples were taken in support of the Sensor Insertion System (SIS). The pump sampling field experiment was a component of a larger experiment entitled "Sediment Transport Rates During Storms" run by the "Storm Team" led by Carl Miller and Don Resio of the U.S. Army Corps of Engineers Waterways Experiment Station (USACE/WES). The VIMS participants in the field component were Grace Battisto, Arno de Kruif, Dann Rijks, Billy Cartwright, Charles "Lyle" Thompson and Robert Ferguson. Eric Grant, Todd Nelson, Wayne Reisner and Steve Snyder helped assemble, install and test the pump system.

The objective of this portion of the study was to collect LISST time series at times corresponding to collection of pumped samples of suspended sediment across the width of the surf zone during a major field experiment called SandyDuck '97. The pumped samples were analyzed for total percent sand (>60 micron), total percent mud (0.8 - 60 micron), organic content and sand size distribution. The LISST measures the particle size distribution from 5-500 microns. The purpose was to provide a high quality data set of pumped samples with which to later test the sensitivity of indirect measurements of suspended sand concentration to the presence of suspended mud. The response of OBSs is known to be particularly sensitive to the presence of suspended mud (turbidity) due to the inverse response of OBS output to grain size. Better constraints on the proper interpretation of OBS time series will improve confidence in conclusions with regards to net along-shelf transport of sand during storms. Standard analysis of the pumped samples does not provide the size distribution of the mud portion of the suspended particles. The LISST time series help fill this gap.

This data report describes the methodology used to pump and collect the suspended sediment samples and the LISST time series as part of the larger Storm Team experiment. The complete results of the sediment filtering (1645 weighed samples) are provided in VIMS data report number 56 entitled "Pump sampling and Sediment Analysis in Support of the Sensor Insertion System, Duck, N.C., April and October, 1997" by G. Battisto and others. This report

provides graphical representation of each LISST time series taken during October 1997. The averaged distribution from each of these time series is then presented in two forms, one plotted as a function of position for each transect along the pier and the other for individual stations shown as a function of time.

## 2. Sampling Technique

### 2.1. Pump system

In this study, four "Teel Industrial Series" Model 1P809A submersible pumps produced by the Dayton Electric Manufacturing Company were employed. Figure 1 shows their mounting arrangement during the October experiment. They operate with 115 V A/C and draw 4.5 amps under full load. Their advantages include their small size (approximately 5"x5"x7") and low price (~\$100) given their relatively strong pumping ability and durability. They also have standard 3/4" garden hose intakes and outlets, which allowed simple deployment of the pumps in series somewhat removed from the sampling inlet location. This was crucial because flow disturbance in the vicinity of the electronic concentration and velocity sensors had to be kept at a minimum.

The Model 1P809A's pump rate according to the manufacturer is 900, 800 and 570 gallons/hour at 1, 9 and 20 ft of head, respectively, dropping off quickly to complete shut-off at 30 ft of head. Because the distance from mean sea level to the high point of the intake hose on the SIS was closer to 40 ft, priming the pumps occasionally caused problems during the field experiments, particularly during a previous storm field experiment in April 1997. In October, maintaining head was only a minor problem, in that all four pumps were installed in series. In April only two pumps were installed in series. The largest problem in October was jamming of the pump impeller with coarse sand and large organic material. Fortunately, another advantage of the Model 1P809A is ease of maintenance. It is quickly disassembled with a screwdriver for internal cleaning and part replacement.

The intake was located 61 cm below the cross-bar on the instrument sensor frame for transects 1-15 and 56 cm below the cross-bar for transects 17-29. The intake, positioned adjacent

to the 6 OBS sensor cluster maintained by the Storm Team, consisted of four 4 mm diameter holes drilled horizontally around the perimeter of the end of a plugged, downward facing PVC tube (Figure 1a). With a consistent pump rate of about 5 gallons/minute the velocity flowing into each of the four holes was  $\sim 6.6$  m/s.

Two 3/4" internal diameter heavy duty hoses and four submersible 115 V A/C power cables extended from the seaward end of the SIS, up through the turn-table of the SIS (also known as the "snake pit"), terminating near the rear end of the truck towing the SIS. Only one of the hoses was active during the October sampling period. The A/C current was kept as far as possible from the communication cables to the electronic sensors on the SIS to minimize potential 60 Hz interference due to the power cables. The pumps were turned on simultaneously utilizing a splash-proof control box with ground fault interrupts.

## 2.2. Sampling procedure

The general sampling procedure for the entire Storm Team group was to transect the surf zone moving landward from the seaward end of the FRF pier. Sampling was done straddling low or high tide in order to keep water level relatively constant. The entire transect generally took about three hours. About every 200 feet, the SIS was deployed to collect a five minute burst of backscatter and current meter data along with pump samples and LISST time series. The pump sampling and collection of LISST time series were performed on a subset of the total number of SIS transects.

If a station included pump sampling, the pumps were turned on as soon as the SIS was put in the water. This allowed several minutes to pass before sediment samples and LISST data were taken. The start time for sediment and LISST sampling was usually within a minute after the start of the OBS collection. With approximately 40 m of hose and a water velocity within the hose of about 117 cm/s, we can expect about a 34 second delay between water intake and appearance of the pumped sample at the barrel. In addition, the signal is expected to be somewhat blurred relative to the "spiky" OBS response due to the shear of the flow within the hose itself.

The hose was terminated in a "Y", with one branch passing through the flow-thru

chamber mounted on the front of the LISST and the other leading to a barrel to collect water to be processed later. Two water samples were collected to correspond to periods within the first and second halves of the OBS burst. Times of sampling were noted for later correlation to times within the OBS burst. Continuous flow into the barrel was maintained. Because of the “Y” split in the flow, it consistently took about 1.6 minutes to fill a 4 gallon barrel (i.e., indicating a total flow rate of ~5 gallons/minute).

### 2.3. LISST calibration and deployment

The LISST, a submersible LISST-100 manufactured by Sequoia Scientific, Inc, was not deployed attached to the boom of the SIS due to the high energy regime of the surf zone and also the flow obstruction the LISST would create. The design of the LISST laser mount makes it sensitive to bumps that could throw the laser out of alignment. It was therefore mounted on a wooden platform (see report cover) attached to the tongue of the SIS. A flow-thru chamber (Figure 2) is designed to allow LISST time series collection from one side of the “Y” on the hose at the same time pumped samples are collected for further analyses. When deployed, the outer chamber contains de-ionized, distilled water so that the laser is always passing through water or acrylic. The inner chamber consists of a debubbler chamber, a sample chamber, and a drain tube. The debubbler allows for bubbles to rise before the sample volume passes in front of the laser. The sample chamber fills as much space as possible between the windows that the laser passes through. The drain tube passes through a hole cut into the table to a hose that has a cutoff valve in-line to allow for control of the outflow. A smaller sample chamber might prevent saturation of the detector as was seen at the peak of the October 1997 storm, by reducing the path length of the laser going through the sample volume.

Any medium that the laser passes through other than water will change the optical properties of the laser beam, as will scratches or smears on the windows. To account and correct for this in the sample collection a Zscat was taken each day. A Zscat is a zero background scattering file that is subtracted from the raw data to remove the laser’s response to anything other than the water sample itself. To obtain a Zscat, the cutoff valve was closed completely and the flow-thru chamber was filled with de-ionized water and 100 scans were recorded and

averaged. Figure 3 shows all the Zscats taken during the field experiment. The X axis is the Ring number of the detector. Each ring corresponds to a discrete range of scattering angles of the laser beam that has passed through the sample volume. The 32 logarithmically spaced rings of the detector are located in the focal plane of the laser receiving lens. The sample volume is 20% less with the flow-thru chamber in place due to the shortening of the optical path length of the instrument from 5 cm to 4 cm by the chamber walls. The Y axis is the raw data response generated by the instrument.

Before any raw data could be converted to provide microliter per liter ( $\mu\text{l/L}$ ) volume concentration files, a calibration of the instrument with a known compound had to be done. A series of concentrations made from a 10% solution of Duke 431 polymer particles, sold by Duke Scientific Corporation, in de-ionized water was used. Duke 431 is a polystyrene polymer, cross-linked with 4-8% divinylbenzene. The polymer is sold as a powder with actual size range of 25-120 microns and a density of 1.05 g/ml. Figure 4 shows the raw data response, in the Y axis, observed to be generated by the concentration in  $\mu\text{l/L}$  of Duke 431 used. The correlation between the concentrations and associated responses is 0.9997. The calibration constant calculated from the average of observed response divided by the known concentration was 4778 counts/ $(\mu\text{l/L})$ . This constant is used by the program before the field data is inverted.

Verification of the instruments capabilities to separate three different particles size ranges accomplished using three single size polymer particle solutions from Duke Scientific. The solutions used were: 4.5 micron, 21.4 micron, and 98.5 micron. The coefficient of variation of the particle size in each of the solutions was 20%, 15% and 11.4% respectively. Figure 5 shows distinct separation of these single size ranges. The Log10 of the particle size in microns is plotted in the X axis and the concentration in microliter per liter is on the Y axis.

### 3. Data

#### 3.1 Particle size distribution for each station

Table 1 summarizes information for each transect sampled by VIMS during the field sampling period known as Sandyduck '97. The first column is the transect number

corresponding to that used by the Storm team deploying the SIS. Column 2 is the date the transect was sampled and Column 3 is the time (EST) the LISST time series was started at the first station of that transect. Column 4 lists all the stations sampled by VIMS. A station number is the distance of the sampling station in feet along the pier, increasing away from the beach.

Section 1 contains a series of graphs of the LISST time series for each of the stations. Due to the "spiky" nature of the data taken at 1 second intervals, 30 second averages are graphed. The X axis is the  $\log(10)$  of the particle size in microns. The Y axis is the number of 30 second intervals where the start time of the first interval is noted in the title of the graph. The Z axis is the  $\log(10)$  of the concentration in  $\mu\text{l/L}$ .

If all the records for the 30 second average were saturated then a zero was recorded for that average otherwise the saturated records were simply removed from the average. For graphing purposes the zeros were changed to 0.0001 so that they would be graphed as -5 on a log scale.

### 3.2. LISST time series averages for each Transect as a function of station

The seven minutes of LISST time series collected were split into two halves. In Section 2 the averages for each half are graphed together by transect. The two halves are printed side by side in this section. The X axis is the  $\log_{10}$  of the particle size. The Y axis contains the stations in feet along the pier sampled for each, transect and the Z axis is the log of the average concentration observed in microliters per liter.

### 3.3. LISST time series averages for each station as a function of transect

In Section 3 the averages for the each half are graphed together by station. The two halves are printed side by side in the section. The X axis is the  $\log_{10}$  of the particle size. The Y axis is the transect number of the station, and the Z axis is the log of the average concentration observed in microliters per liter.

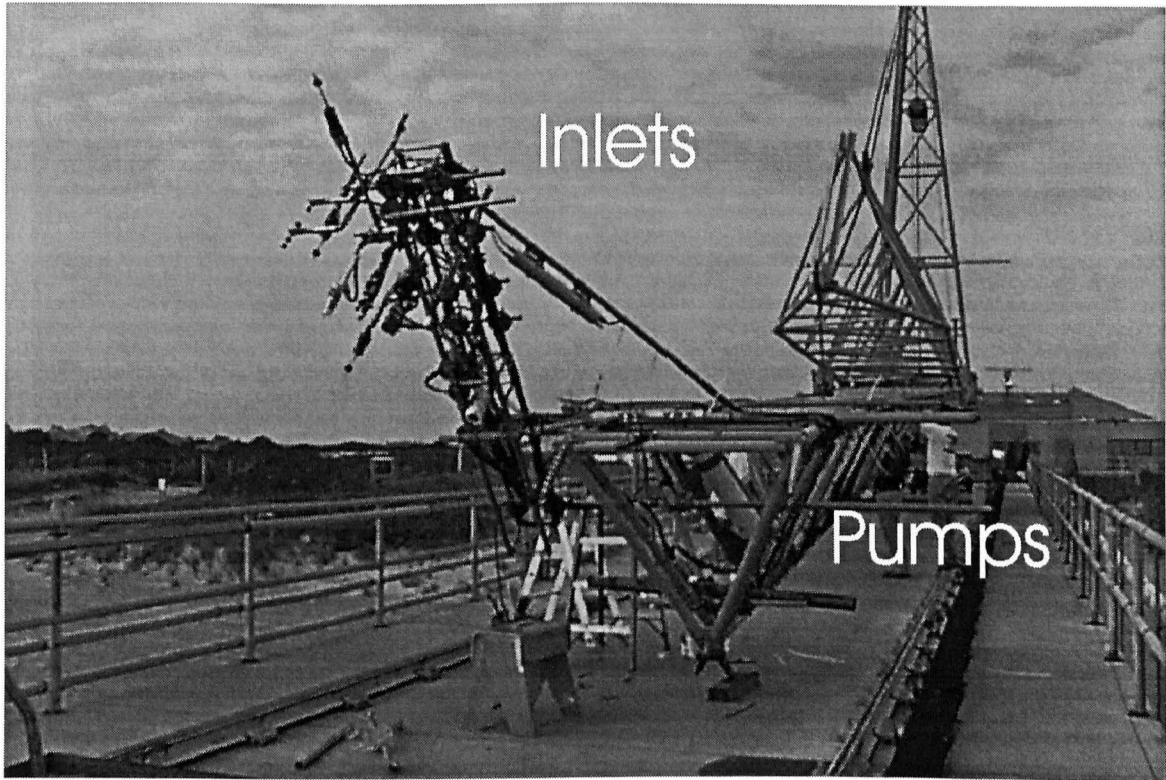

Figures 1a and 1b

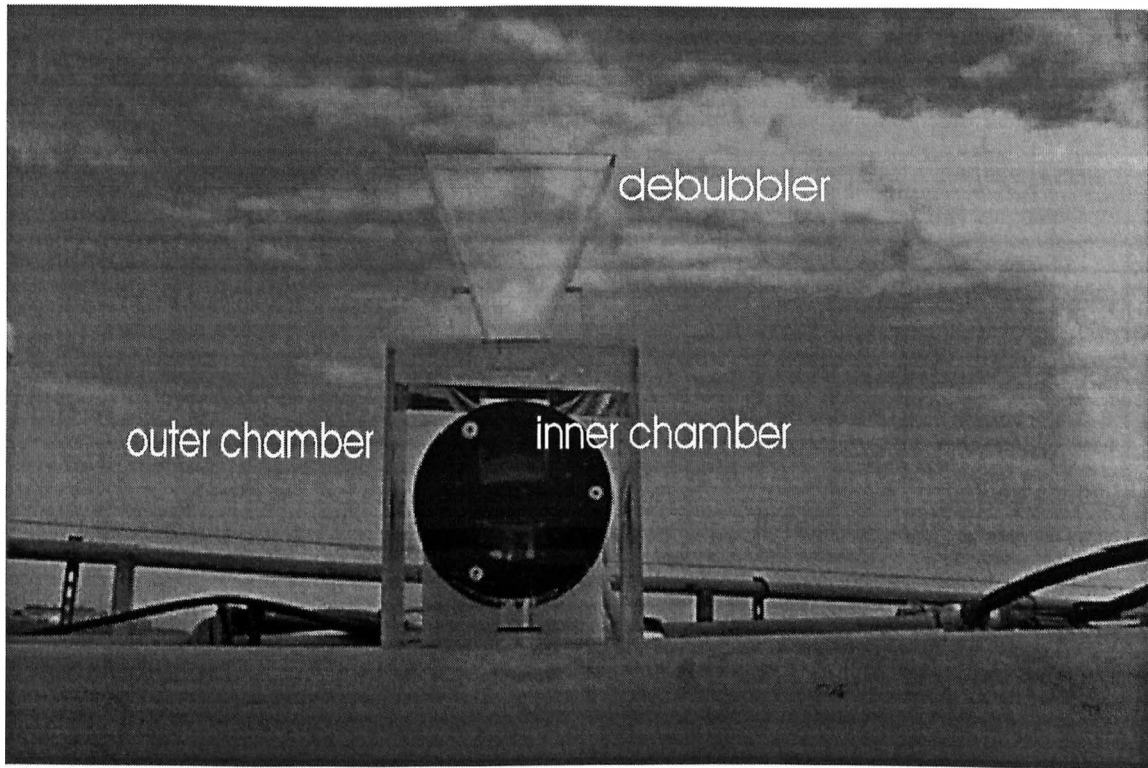

Figure 2

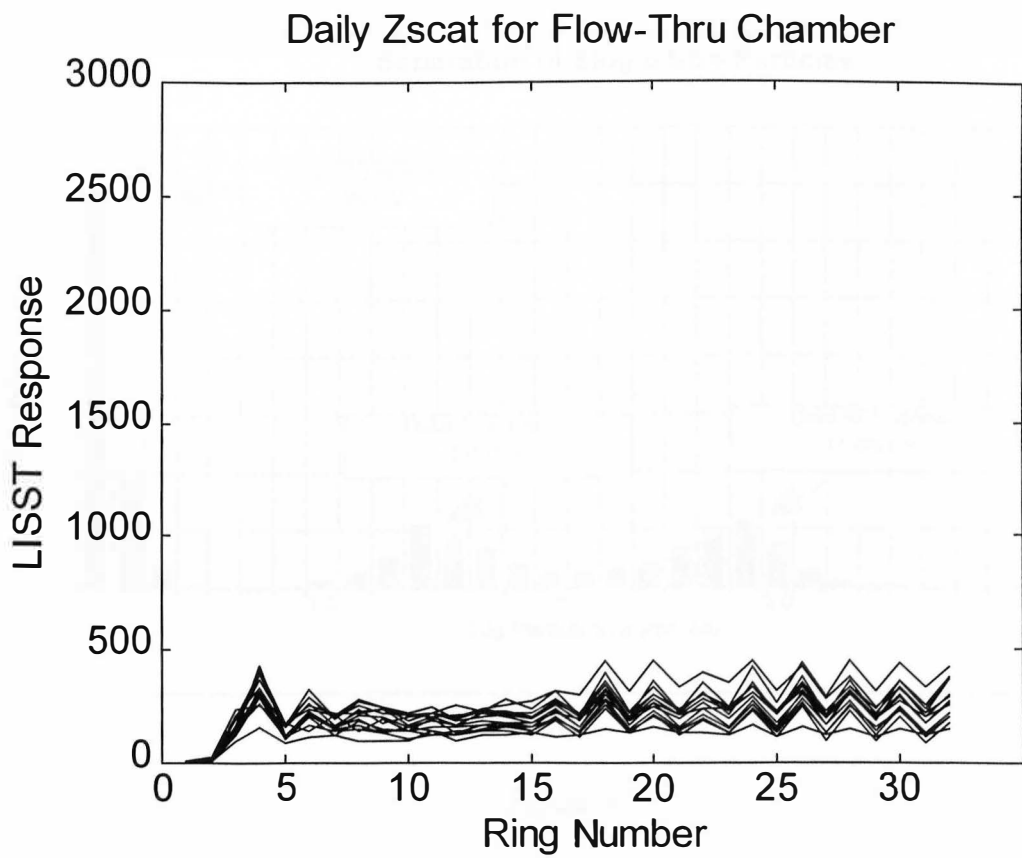

Figure 3

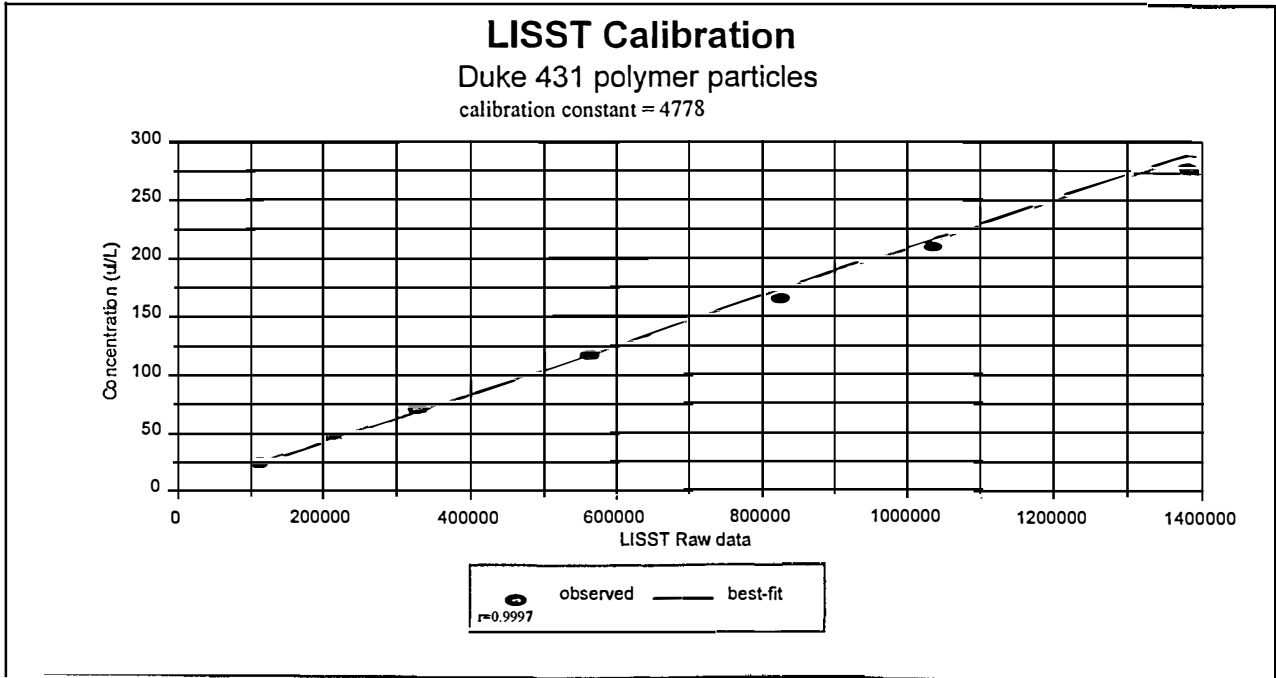

Figure 4

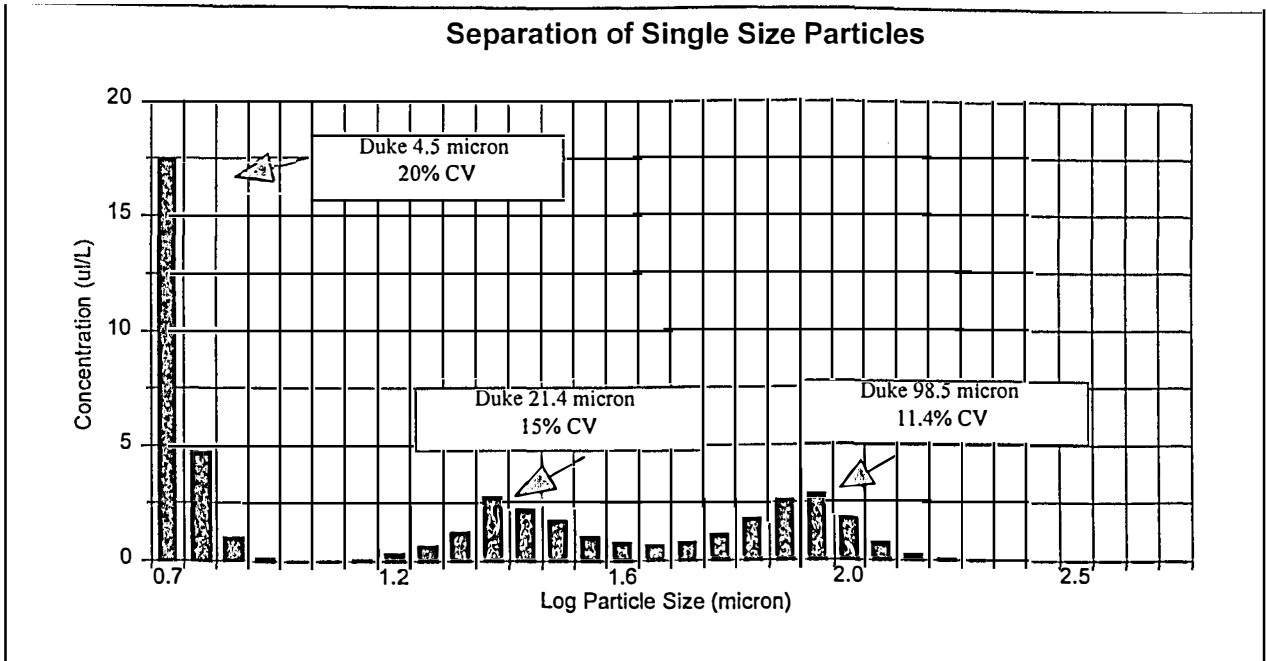

Figure 5

**Table 1            Sandyduck '97            Transect Information**

<u>Transect</u>	<u>Sample Date</u>	<u>1<sup>ST</sup> Station</u>	<u>Stations (feet along pier)</u>
		<u>Start time</u>	
1	971007	0909 EST	1700 1490 1250 1050 890 770 650 520
2	971008	1028	1700 1490 1250 1050 900 780 650 550
3	971009	1042	1700 1500 1260 1030 900 770
4	971010	1120	1700 770 650
6	971013	0907	1700 780
7	971014	1600	1690 1500 1250 1030 900 770 660 540
8	971015	1743	1700 1500 1360 1260 1140 1030 900 770 650
10	971016	0525	1700 1530
11	971016	1808	1500 1250 1140 1040 900 720 660
13	971017	1700	1700 1500 1270 1140 1020 900 780
14	971017	1852	1700 1610 1500 1360 1250 1120 1040 900 780 650
15	971018	0655	1700 1500 1260 1140 1050 890 770
17	971018	1919	1730 1610 1490 1350 1250 1050 900
19	971019	0731	1770 1700 1520 1400 1260 1140 1050 900
21	971019	2003	1750 1700 1500
23	971020	0841	1770 1700 1530 1400 1140
24	971020	1536	1610 1500 1380 1260
26	971021	0942	1760 1700 1520 1280 1140 920
27	971021	1615	1700 1610 1500 1370 1250 1130 920 770
28	971022	1023	1700 1500 1250 1130 1050 900 770
29	971023	1248	1760 1500 1250 1050 900 770 650

## Section 1

LISST Time Series  
30 second Averages  
for each Station

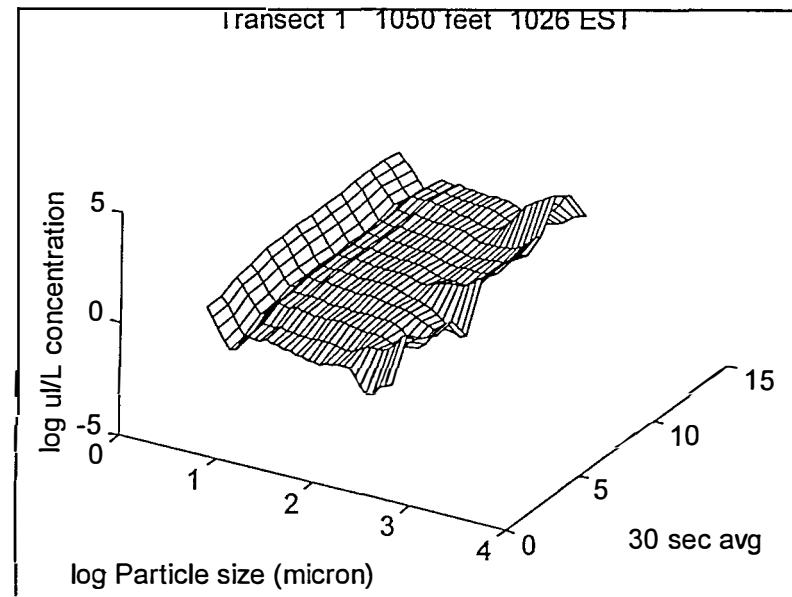
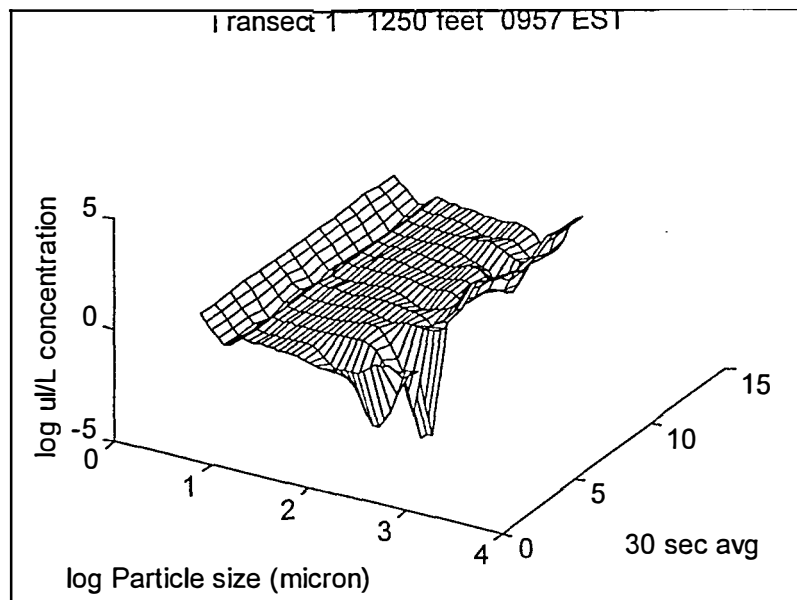
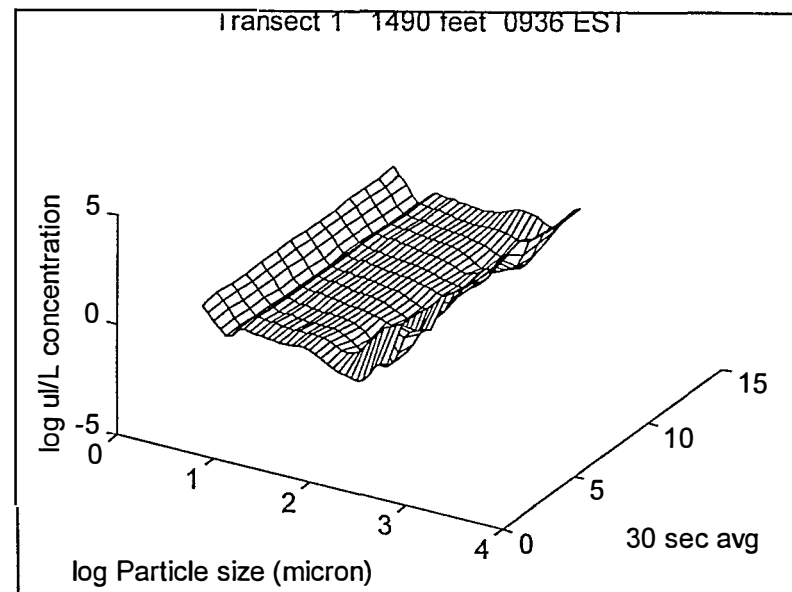
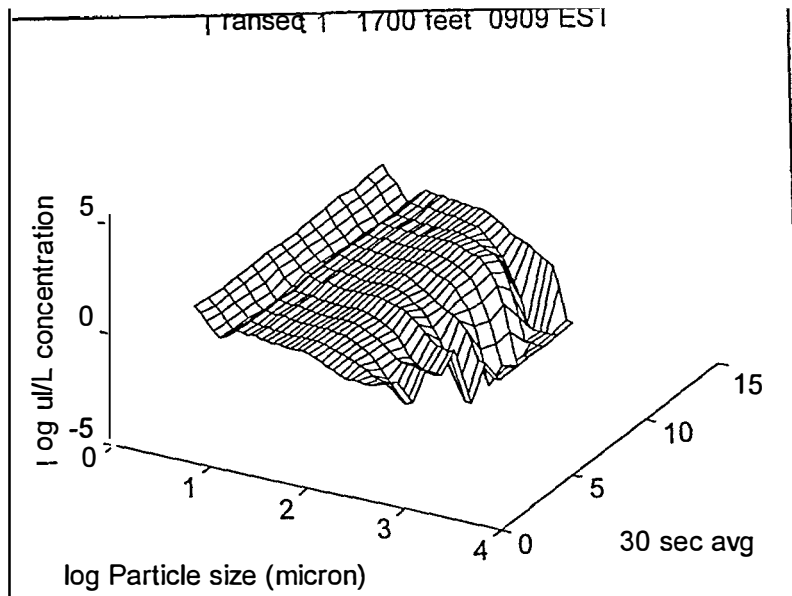

Transect 1 890 feet 1053 EST

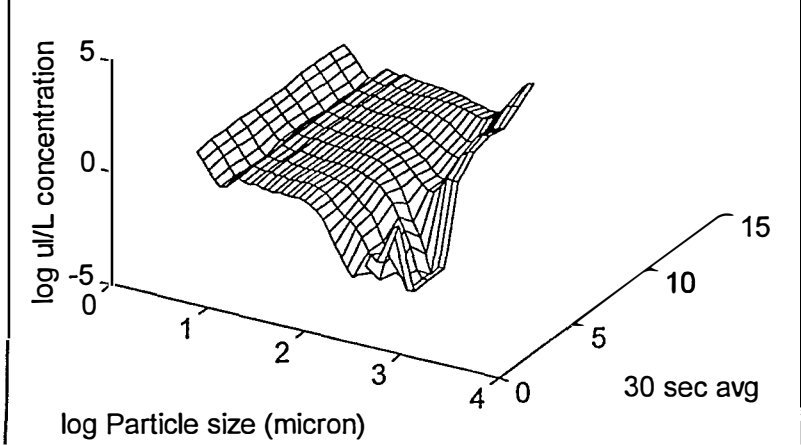

Transect 1 770 feet 1119 EST

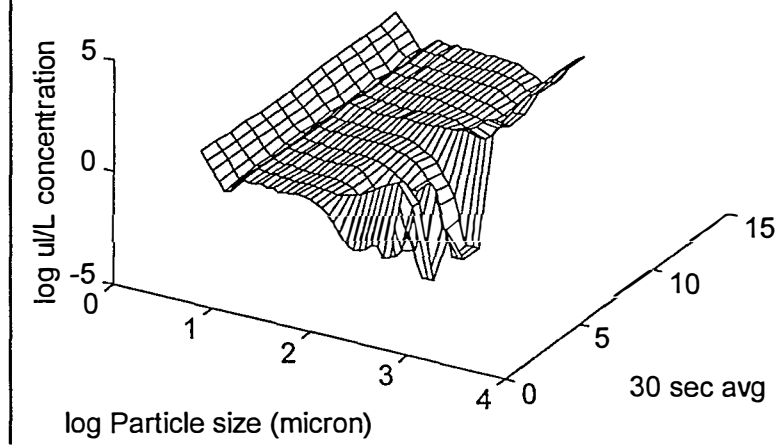

Transect 1 650 feet 1145 EST

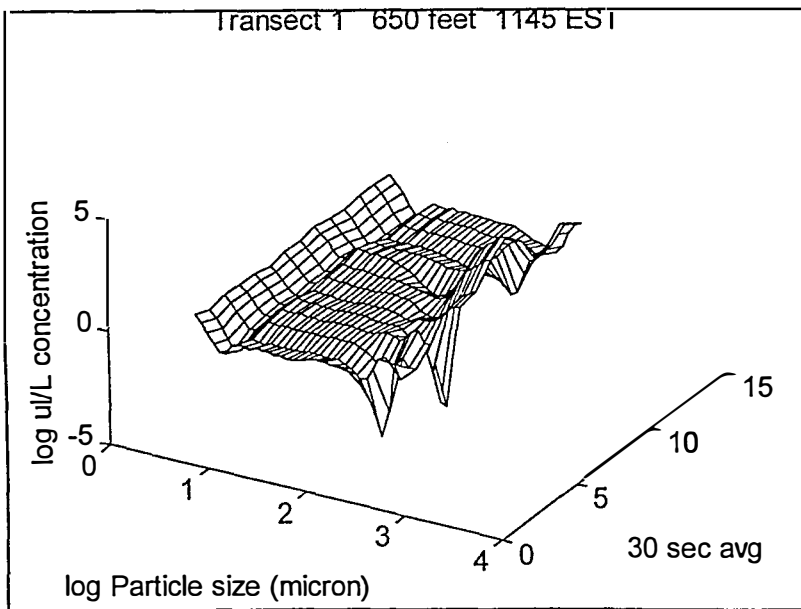

Transect 1 520 feet 1222 EST

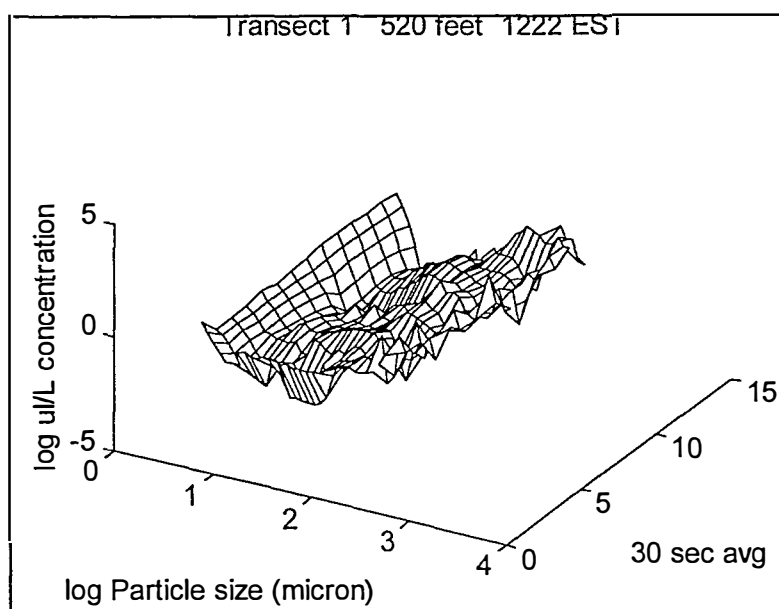

Transect 2 1700 feet 1028 EST

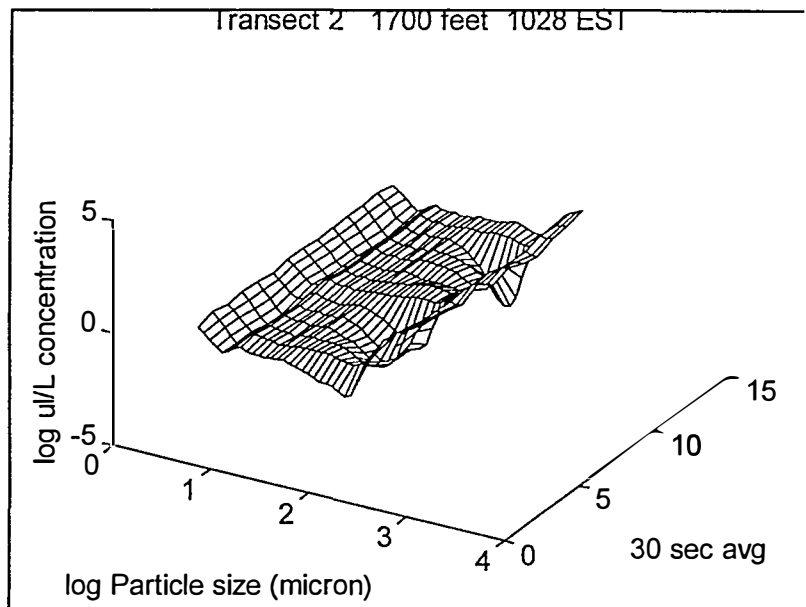

Transect 2 1490 feet 1102 EST

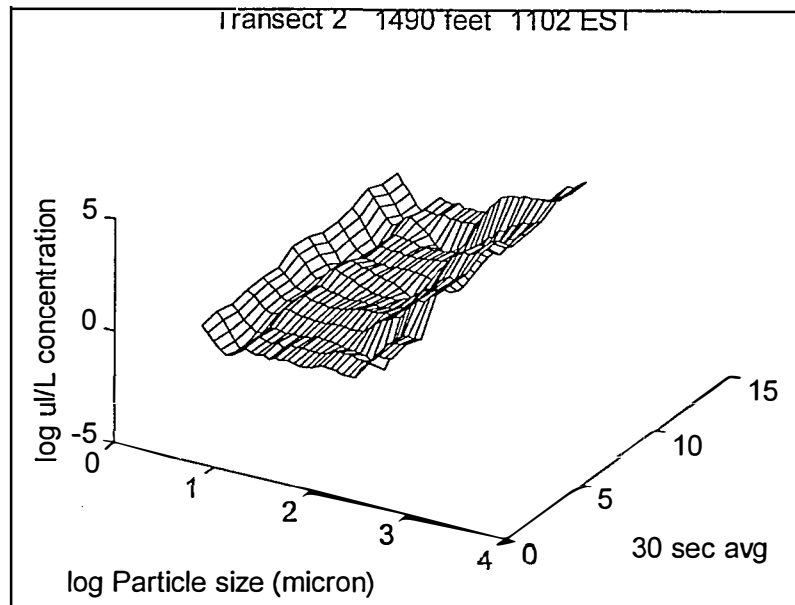

Transect 2 1250 feet 1132 EST

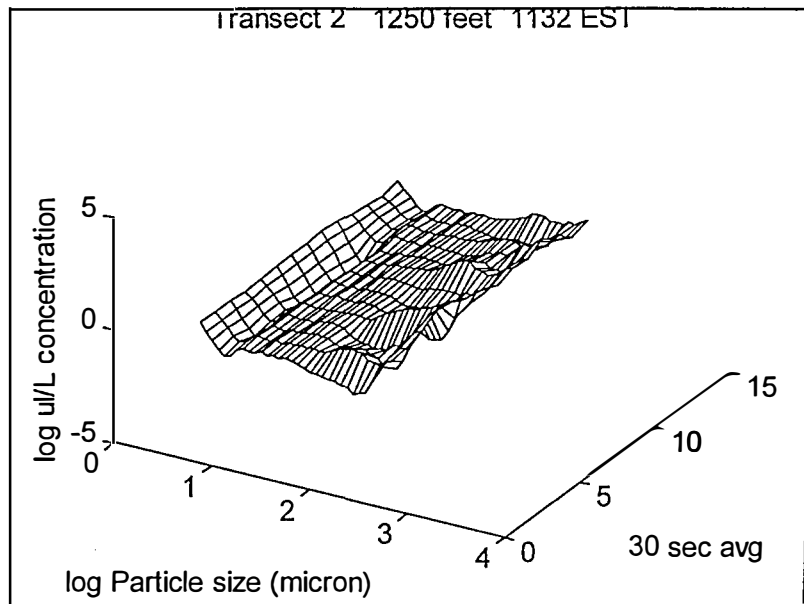

Transect 2 1050 feet 1203 EST

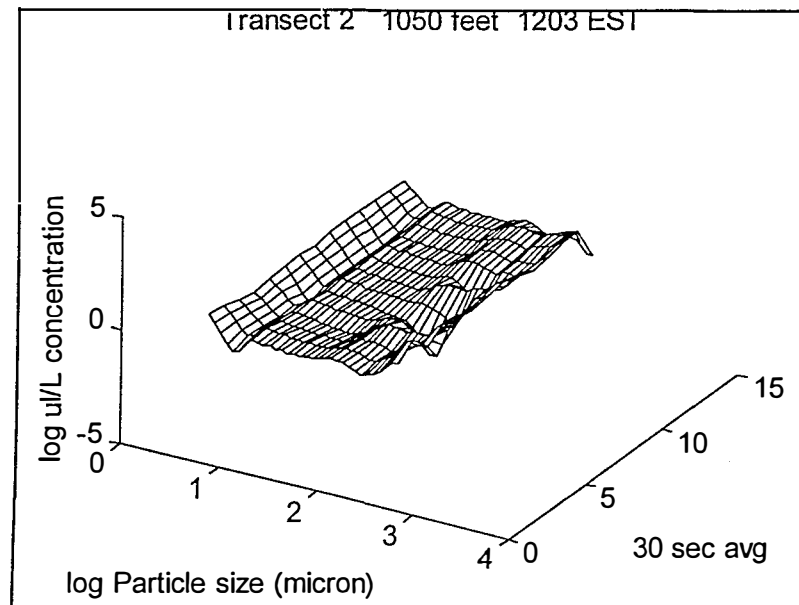

Transect 2 900 feet 1233 EST

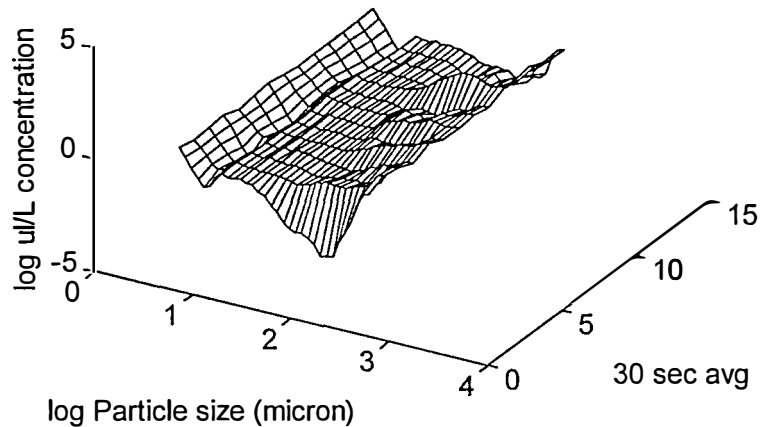

Transect 2 780 feet 1300 EST

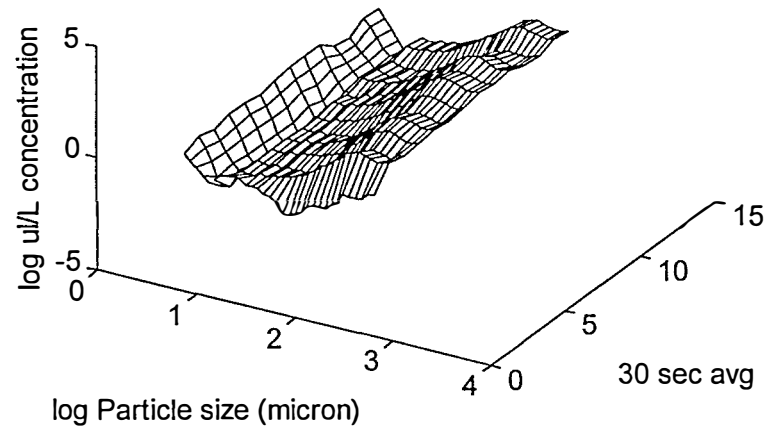

Transect 2 650 feet 1321 EST

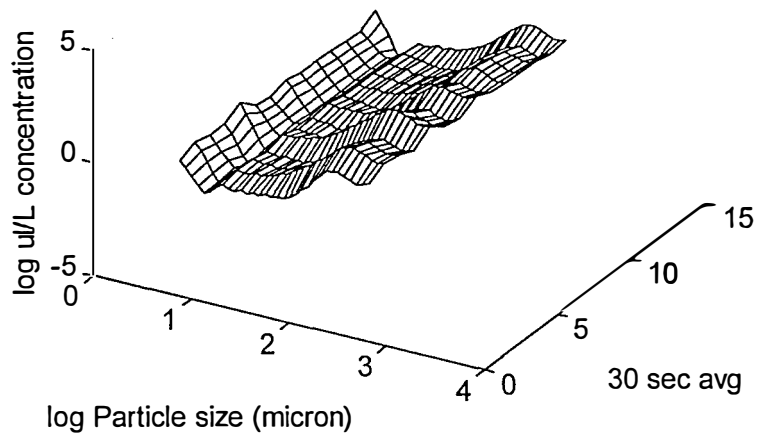

Transect 2 550 feet 1357 EST

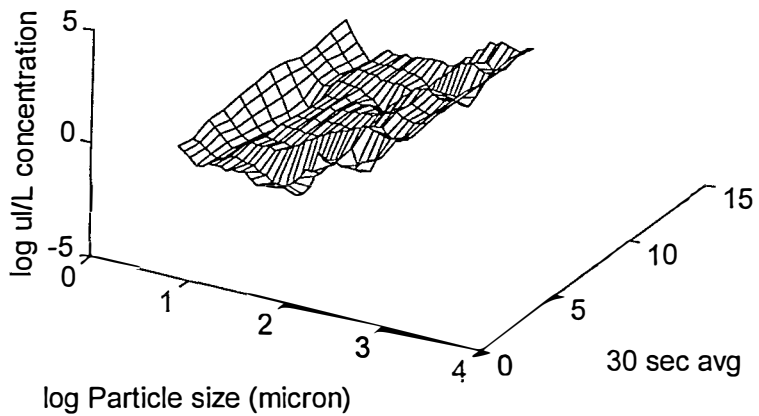

Transect 3 1700 feet 1042 EST

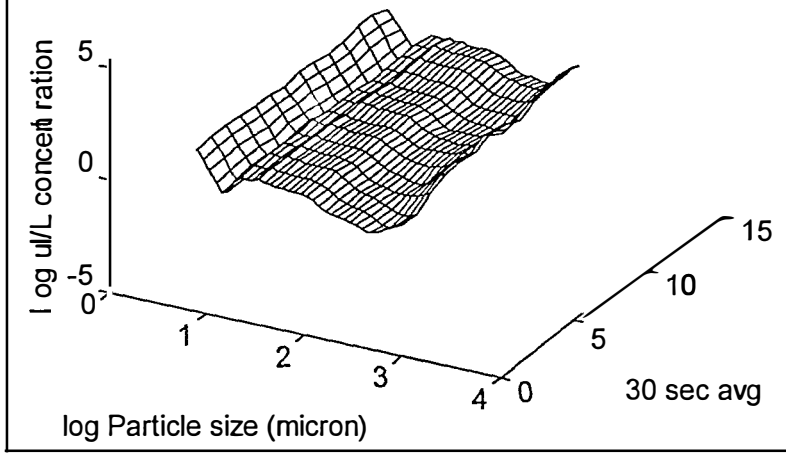

Transect 3 1500 feet 1116 EST

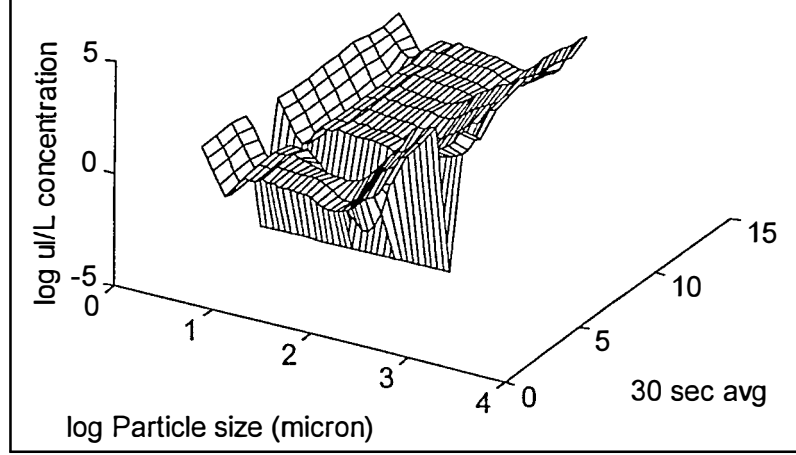

Transect 3 1260 feet 1145 EST

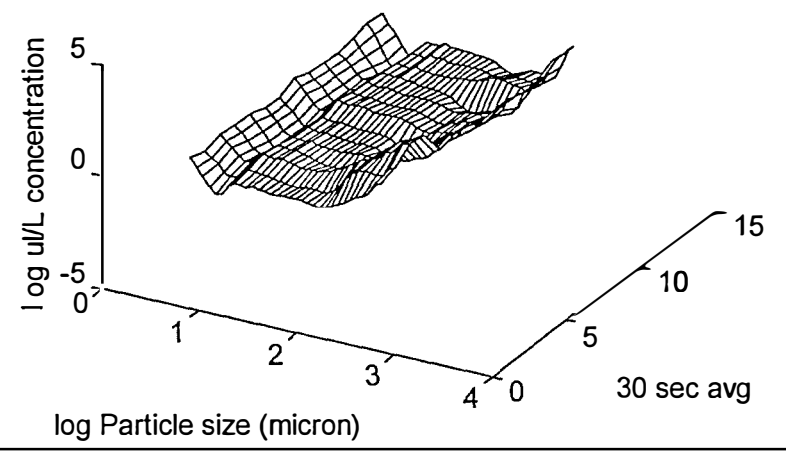

Transect 3 1030 feet 1239 EST

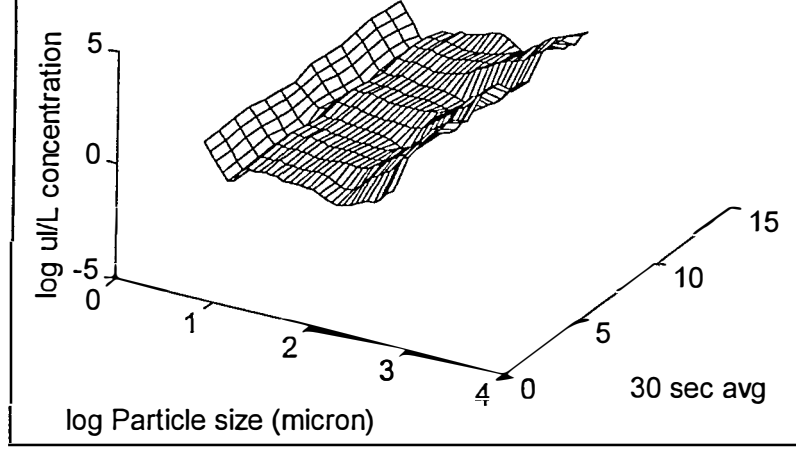

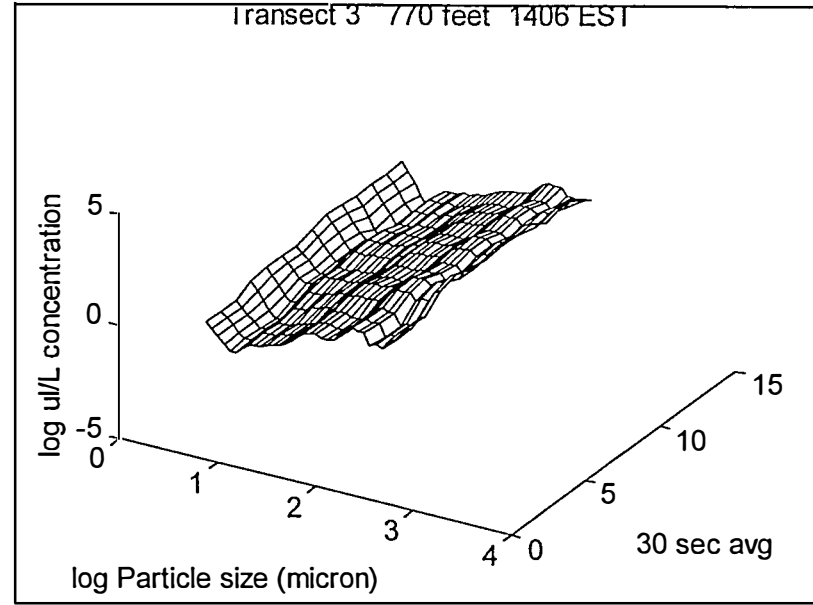
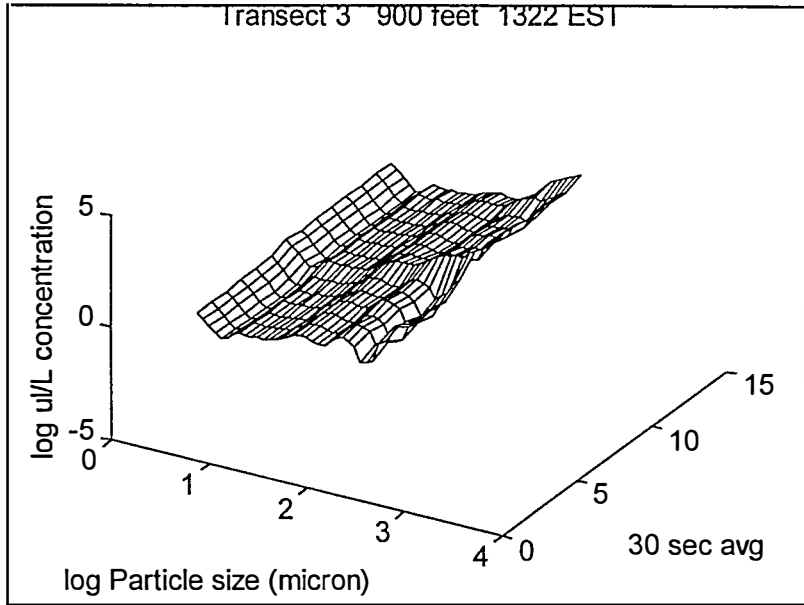

Transect 4 1700 feet 1120 EST

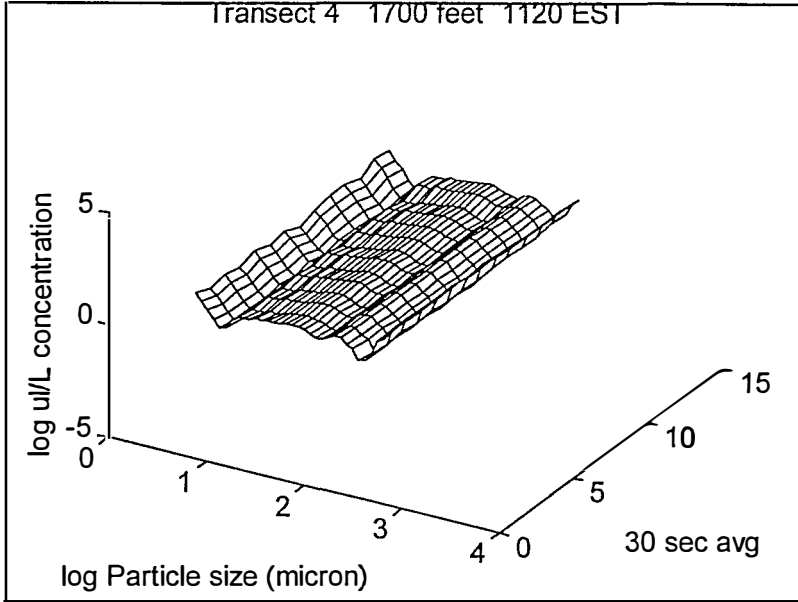

Transect 4 770 feet 1417 EST

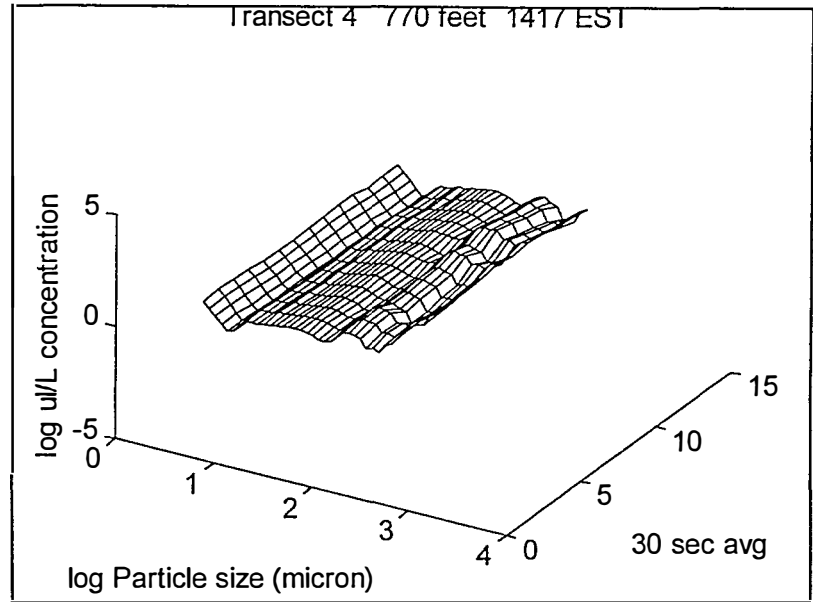

Transect 4 650 feet 1441 EST

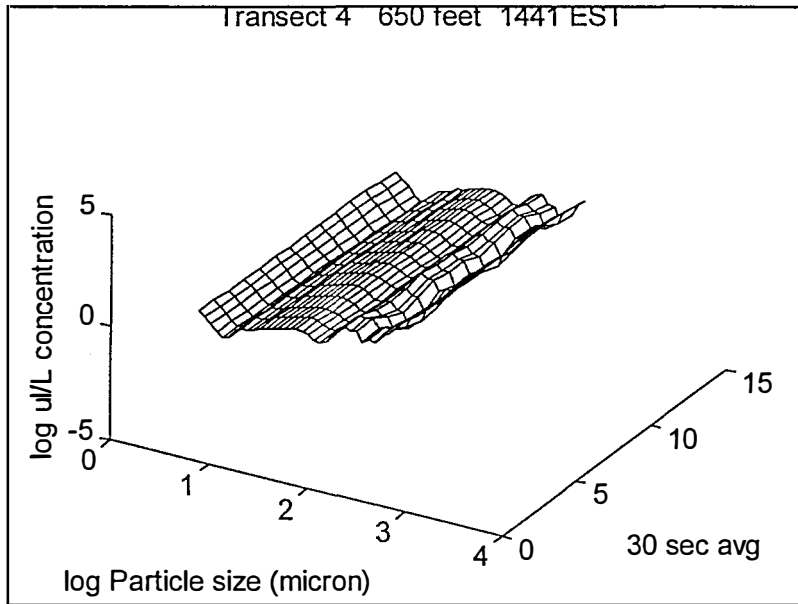

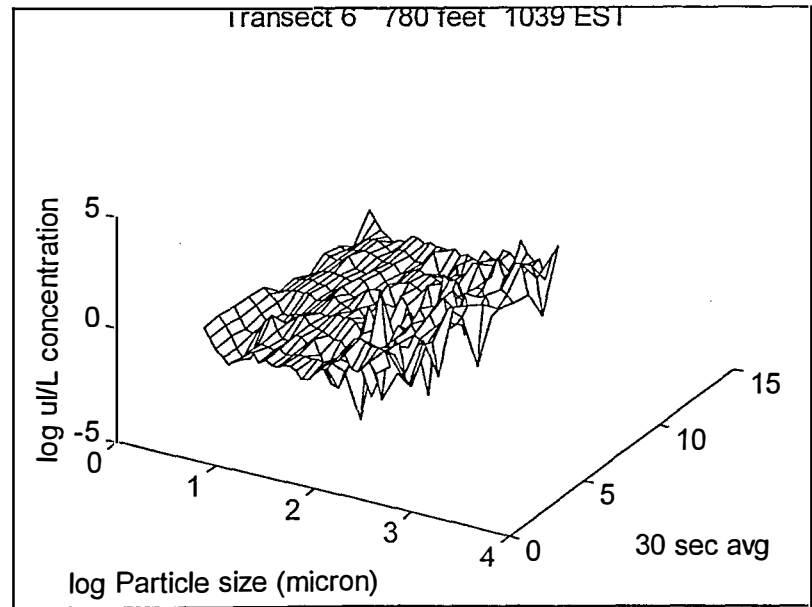
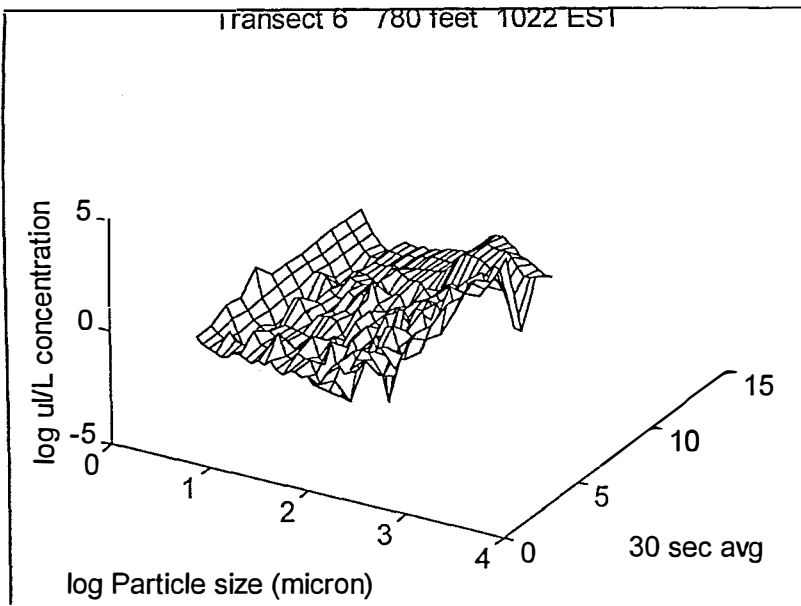
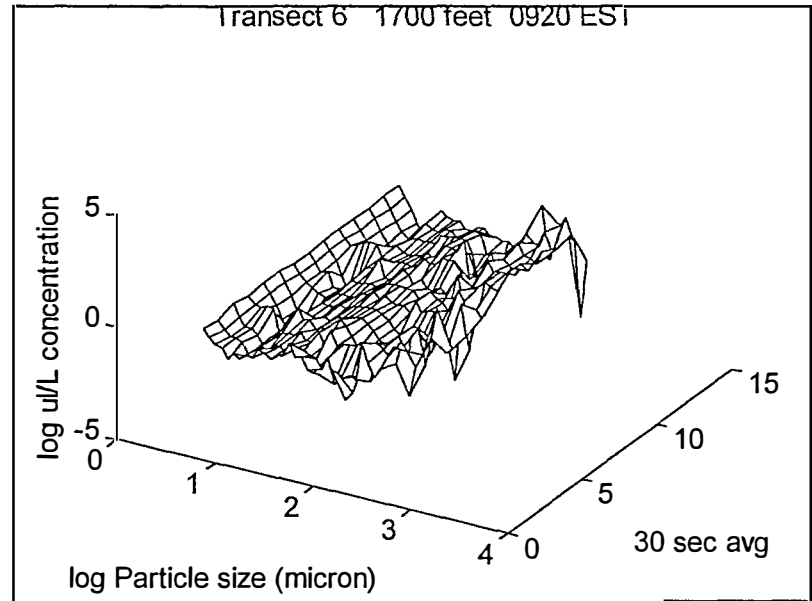
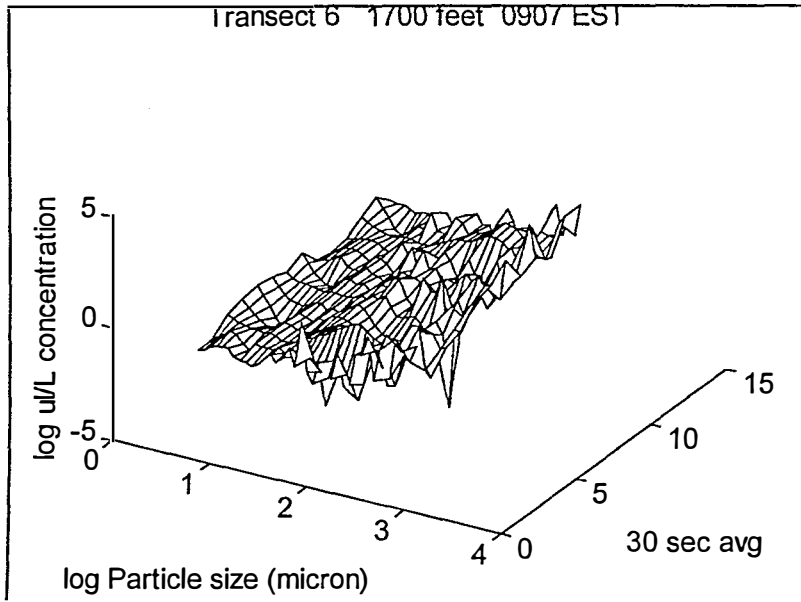

Transect 7 1690 feet 1600 EST

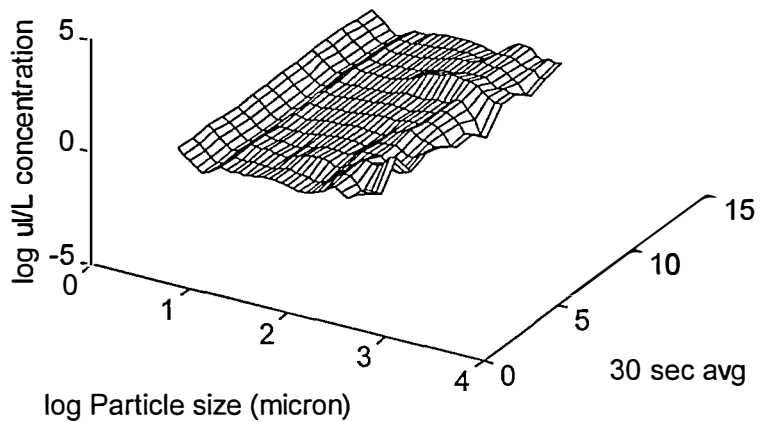

Transect 7 1500 feet 1634 EST

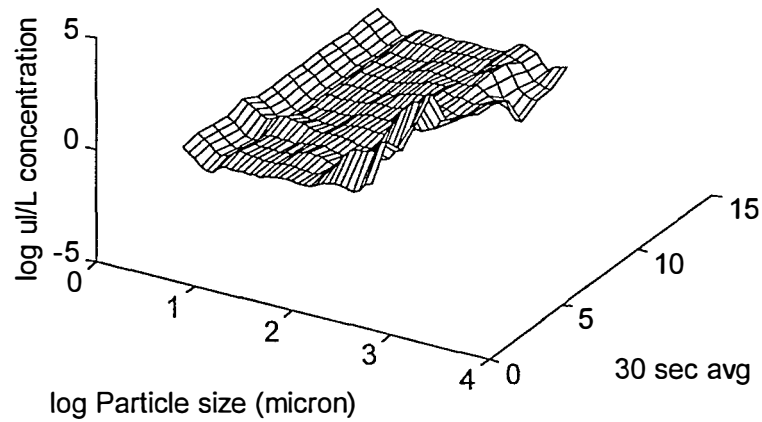

Transect 7 1250 feet 1700 EST

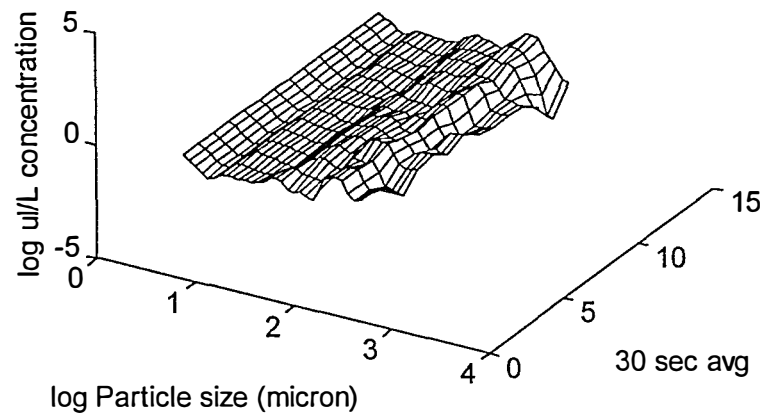

Transect 7 1030 feet 1731 EST

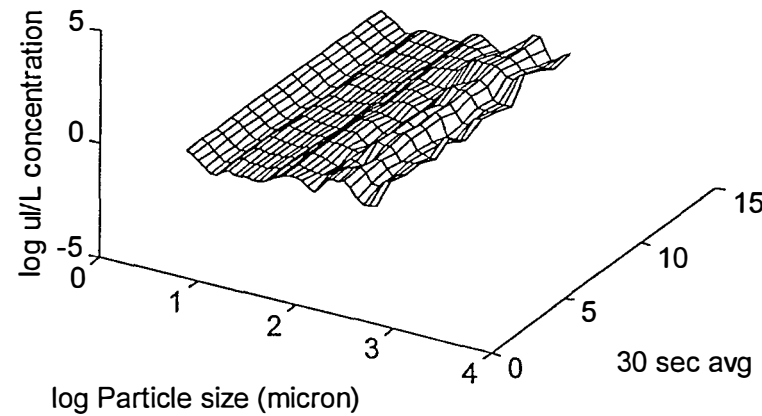

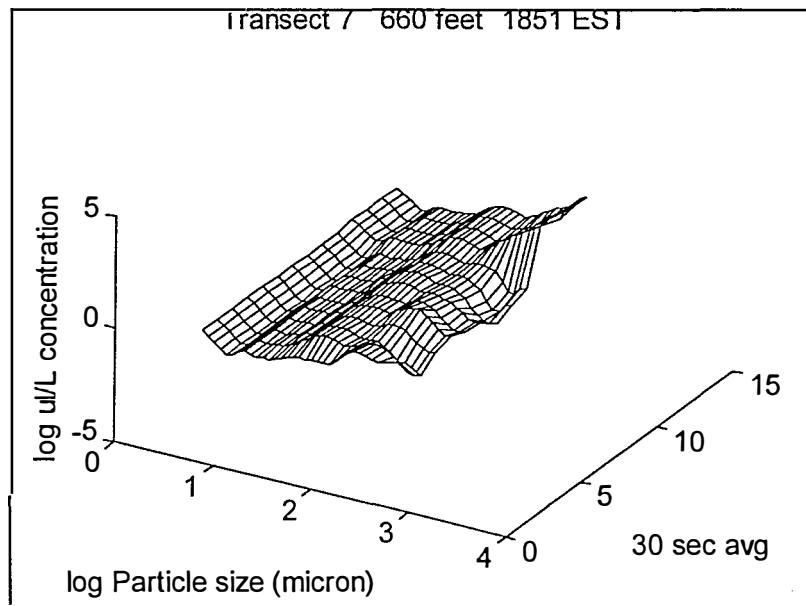
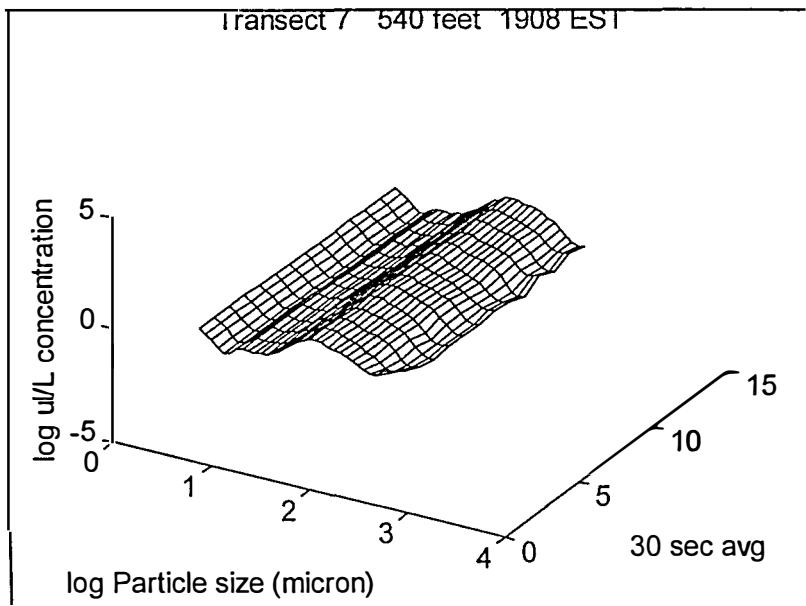
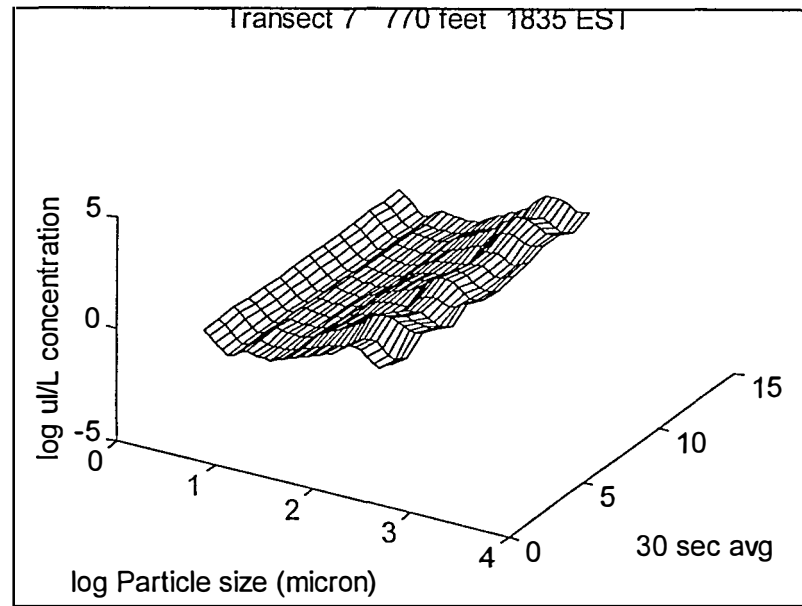
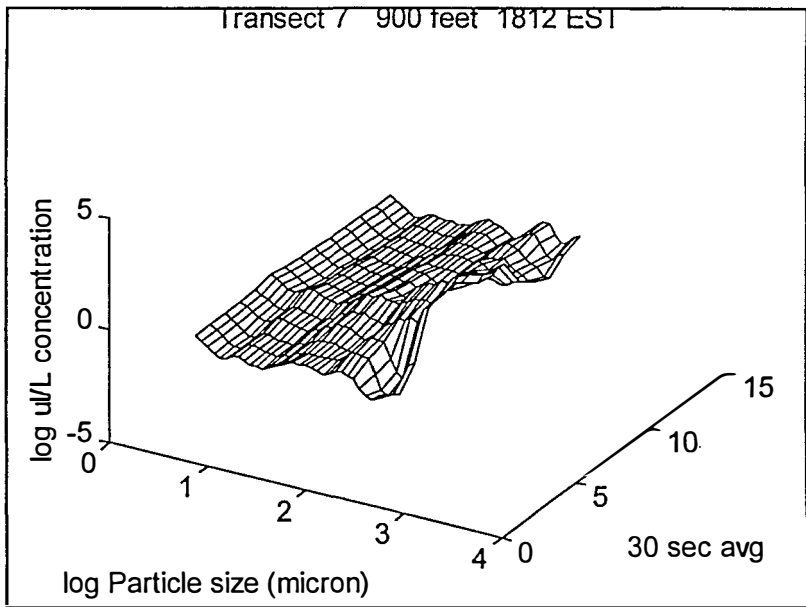

Transect 8 1700 feet 1743 EST

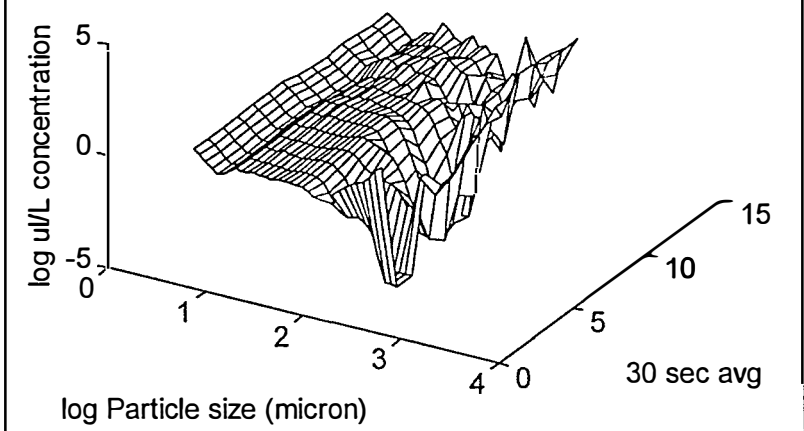

Transect 8 1500 feet 1809 EST

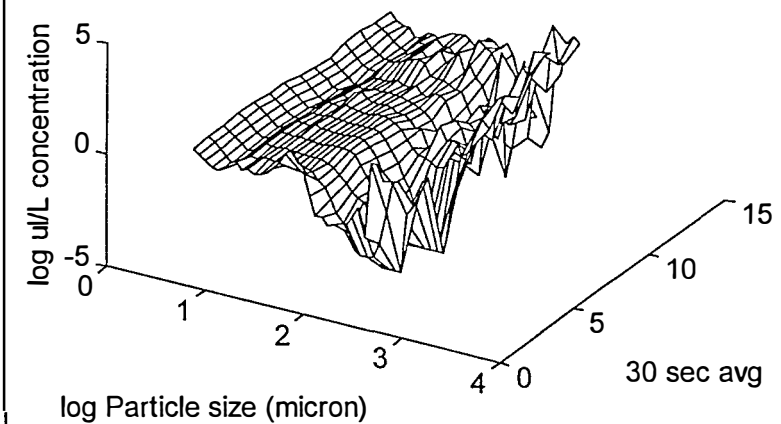

Transect 8 1360 feet 1827 EST

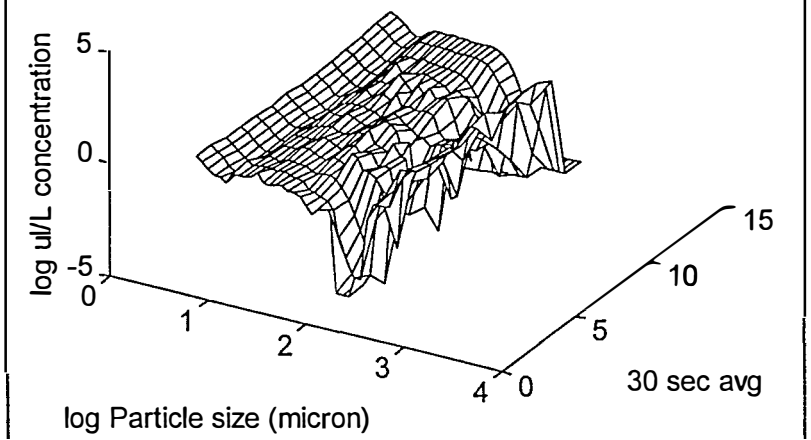

Transect 8 1260 feet 1843 EST

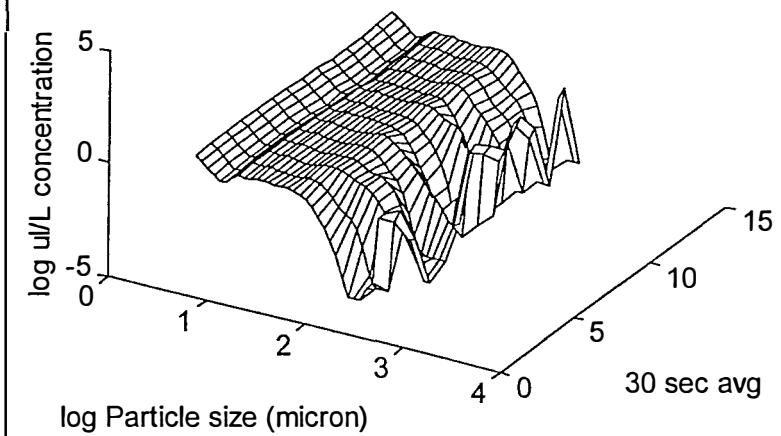

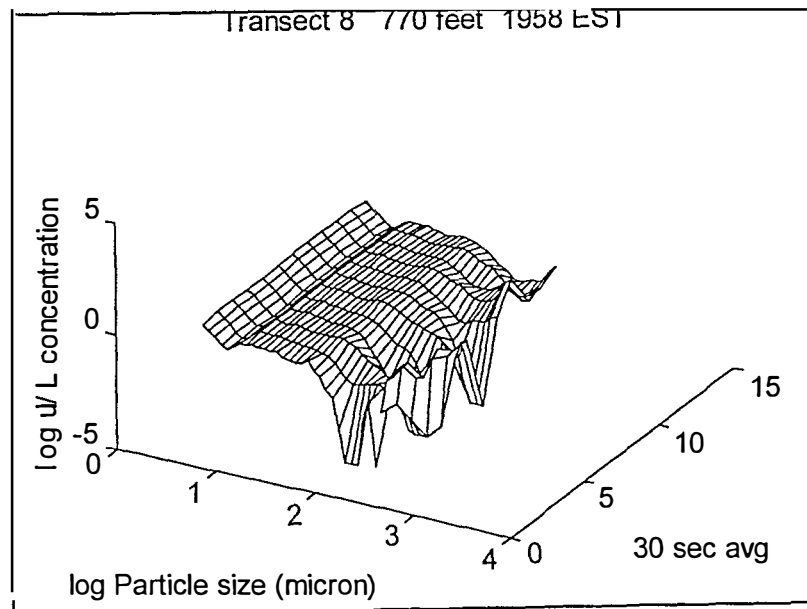
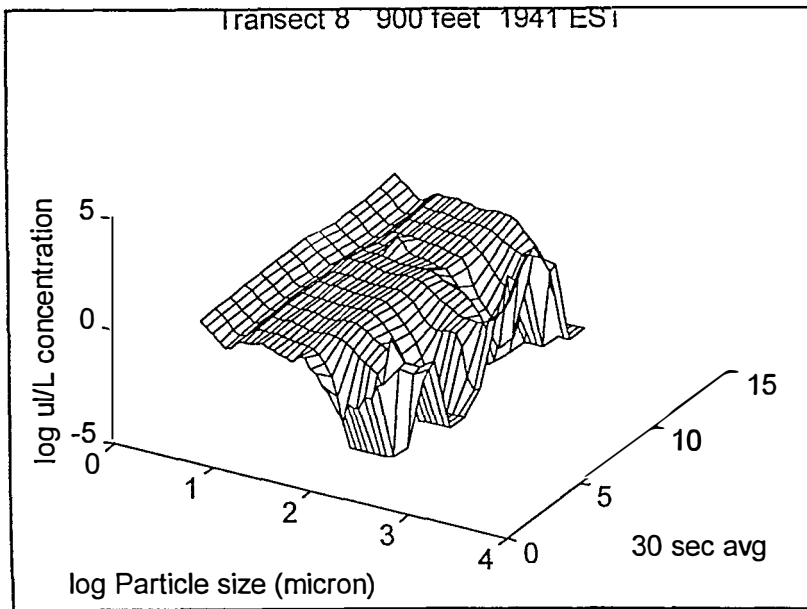
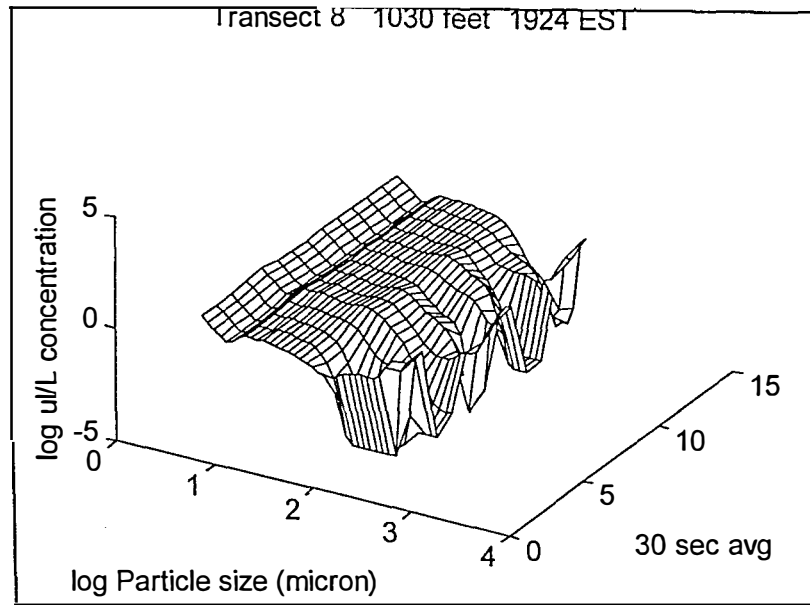
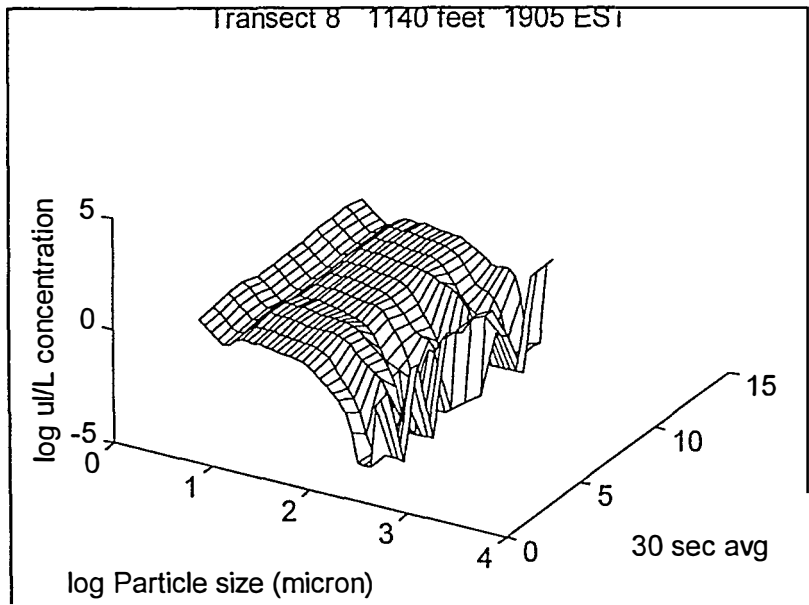

Transect 8 650 feet 2015 EST

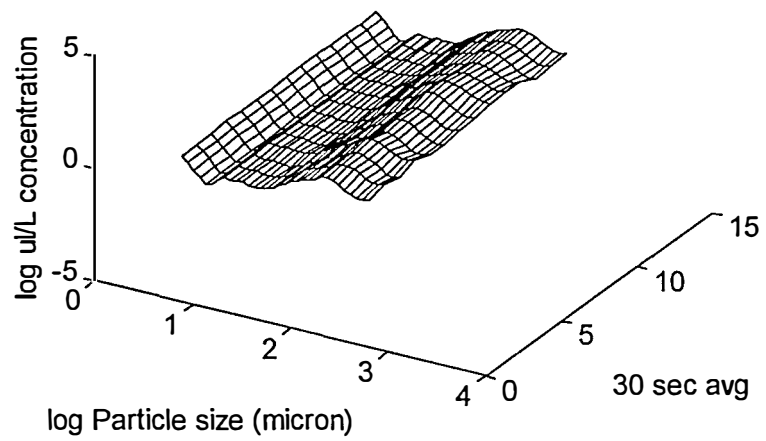

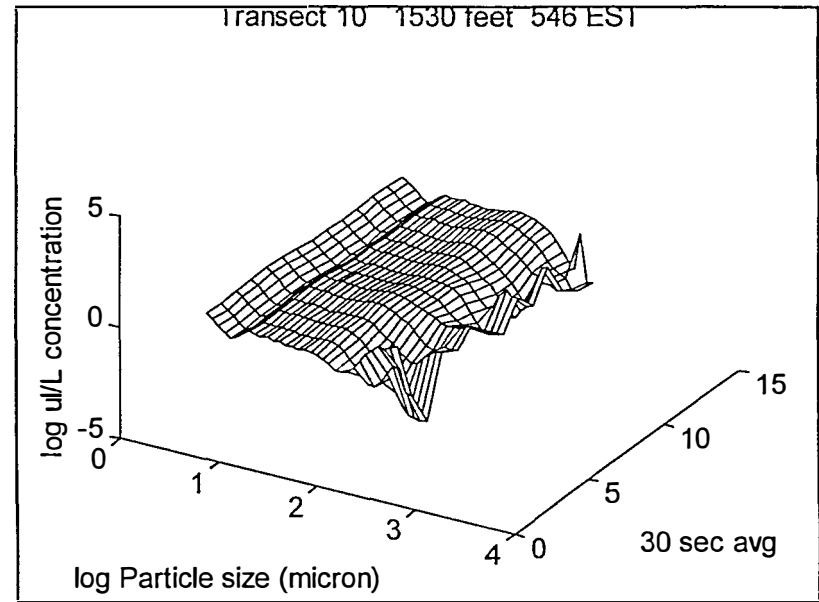
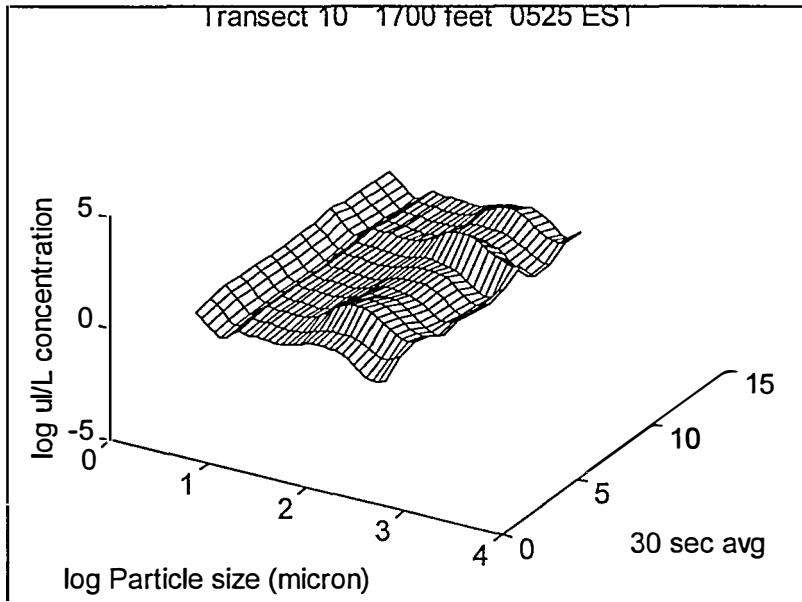

Transect 11 1500 feet 1808 EST

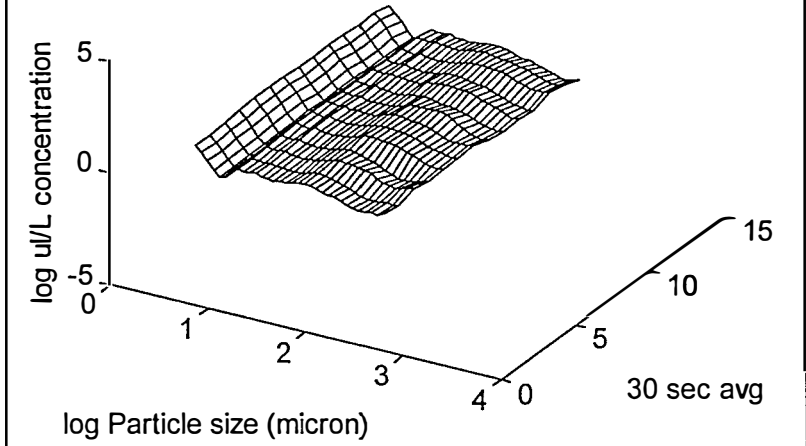

Transect 11 1250 feet 1826 EST

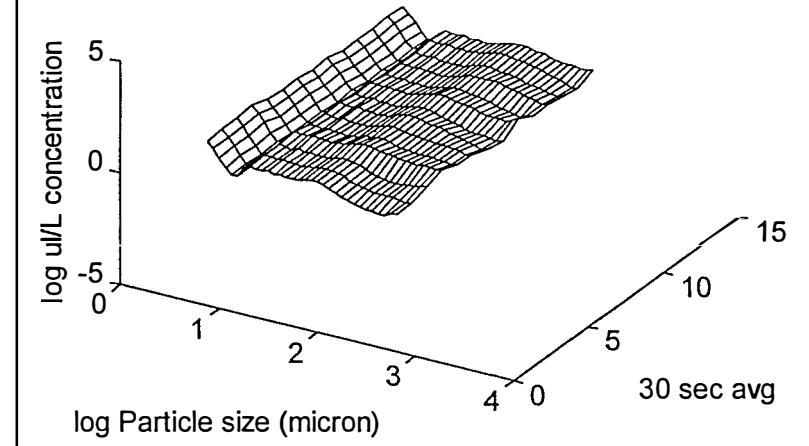

Transect 11 1140 feet 1845 EST

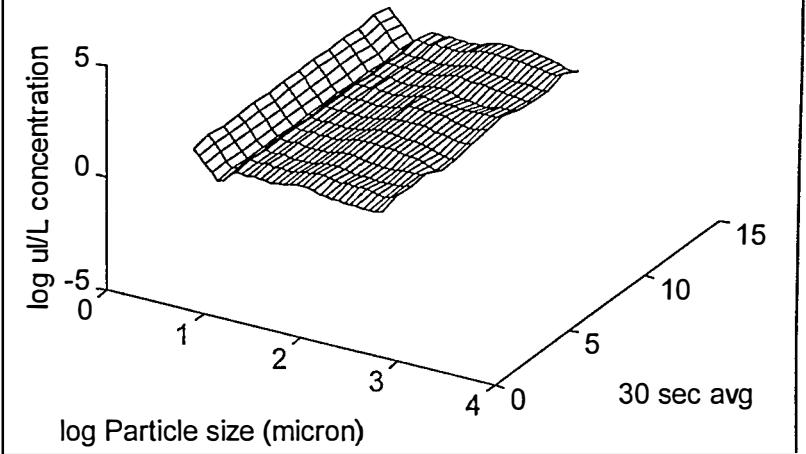

Transect 11 1040 feet 1900 EST

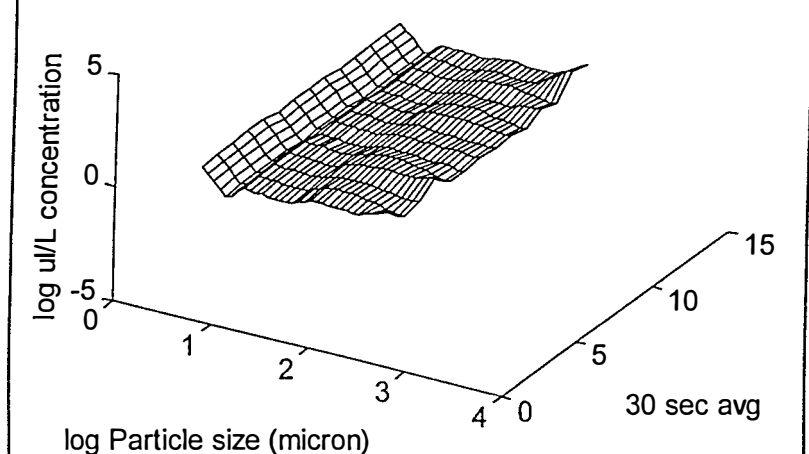

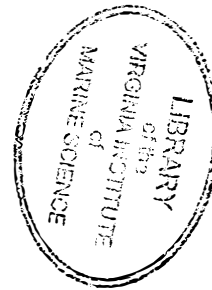
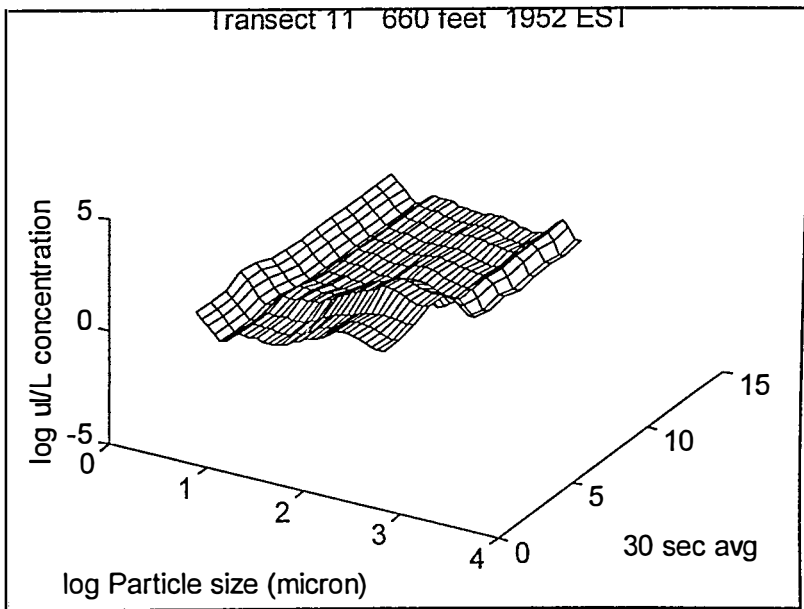
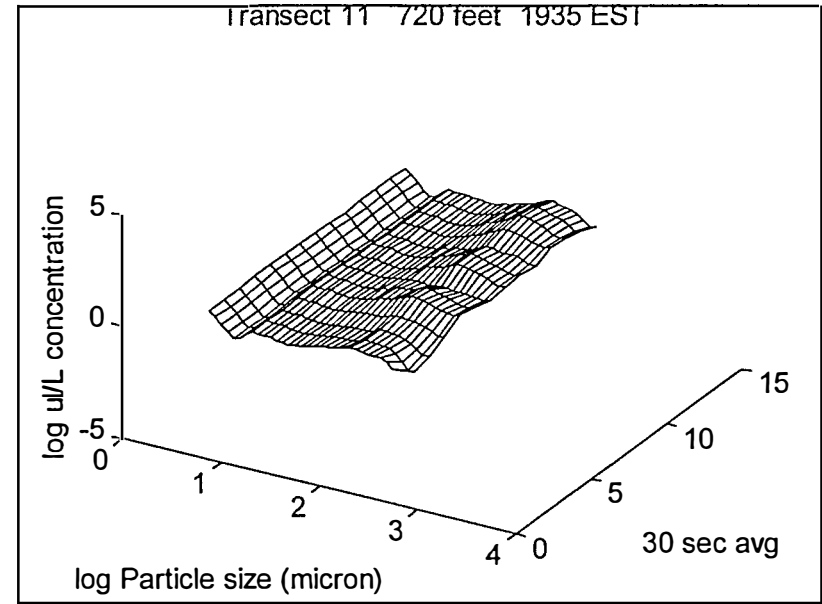
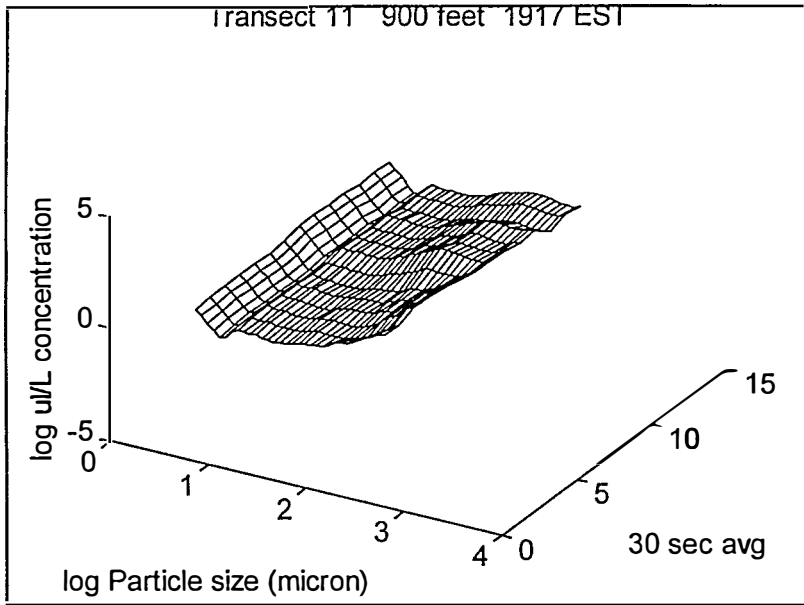

Transect 13 1700 feet 1219 EST

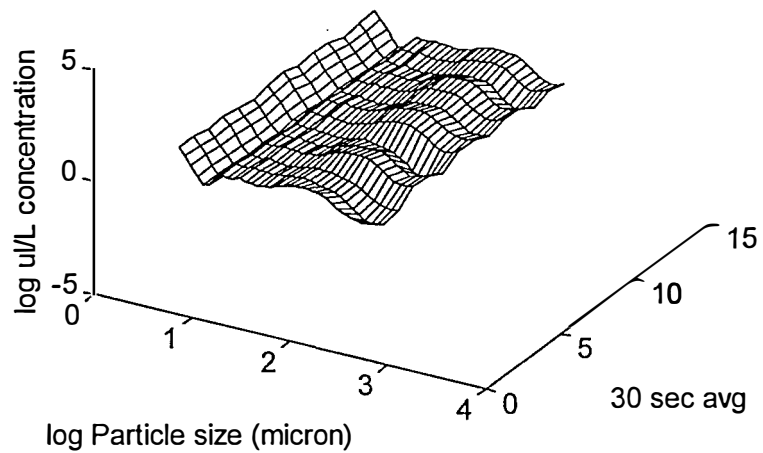

Transect 13 1500 feet 1251 EST

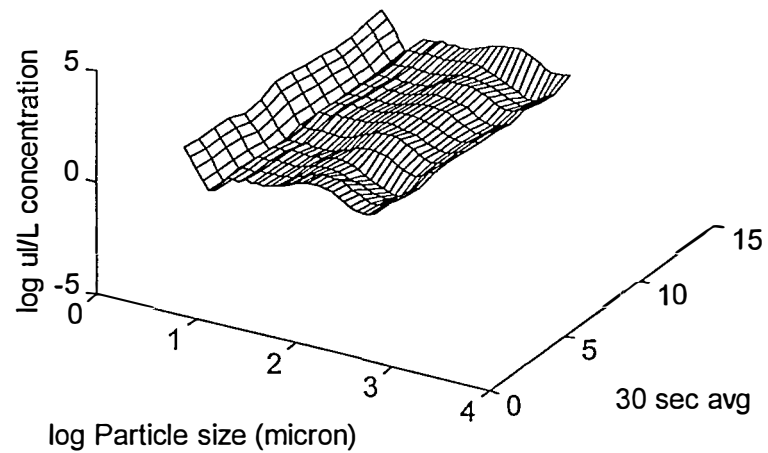

Transect 13 1270 feet 1317 EST

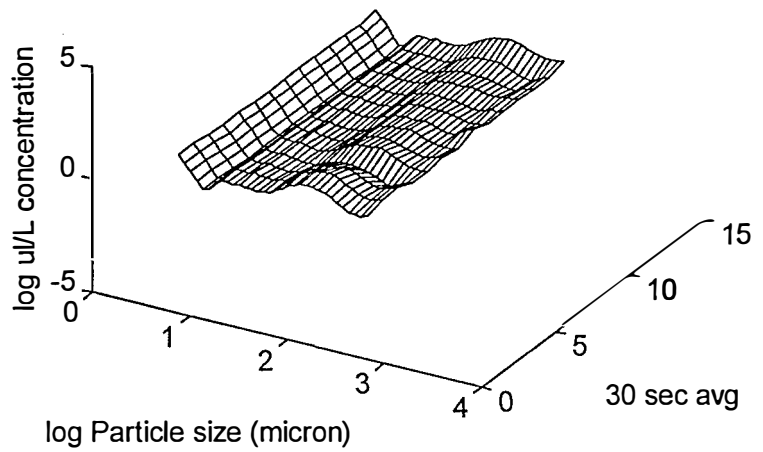

Transect 13 1140 feet 1341 EST

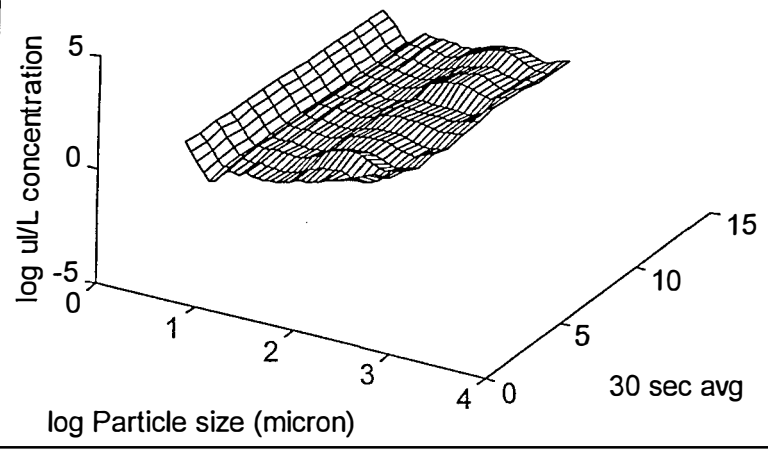

Transect 13 1020 feet 1404 EST

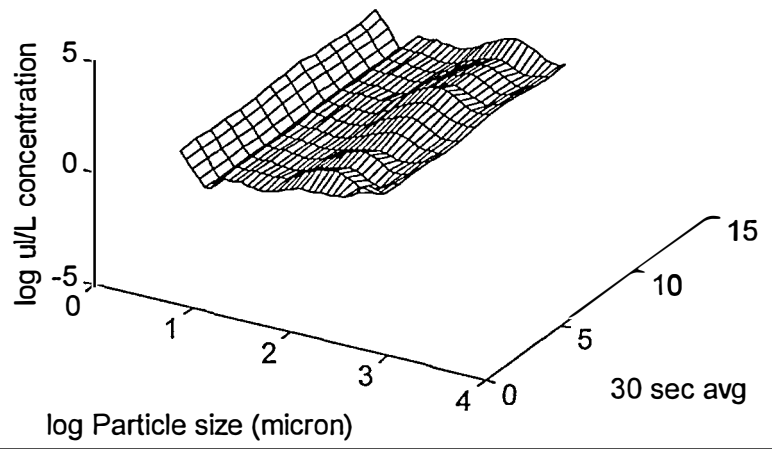

Transect 13 900 feet 1430 EST

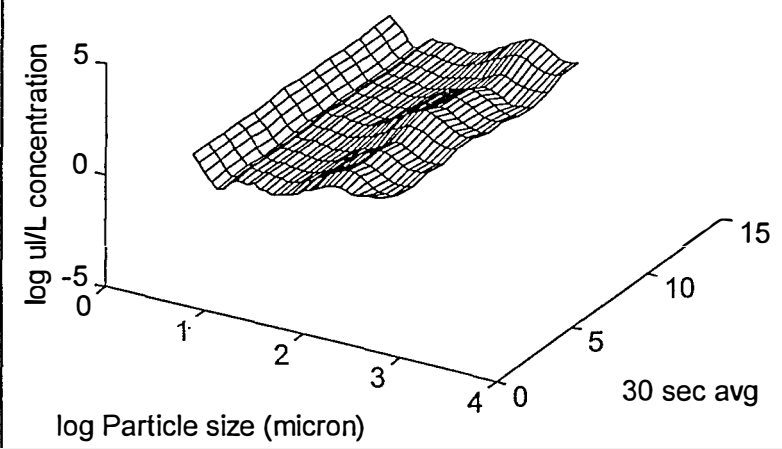

Transect 13 780 feet 1454 EST

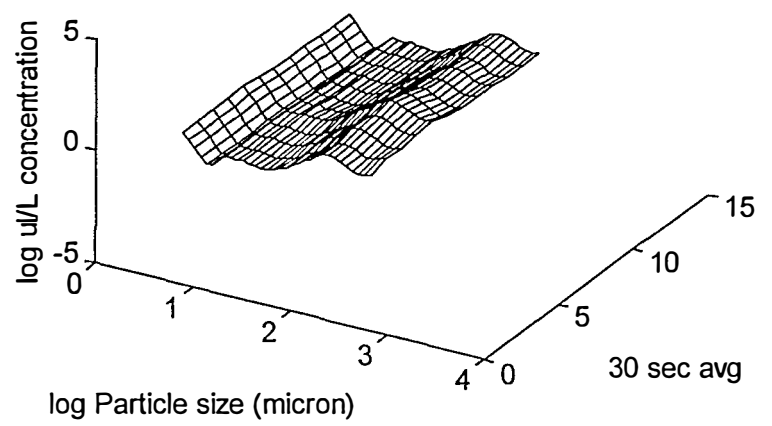

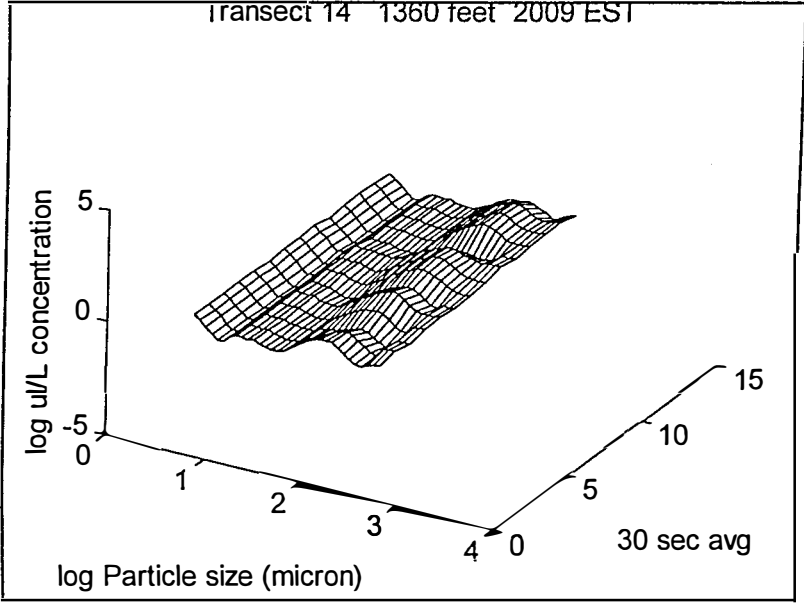
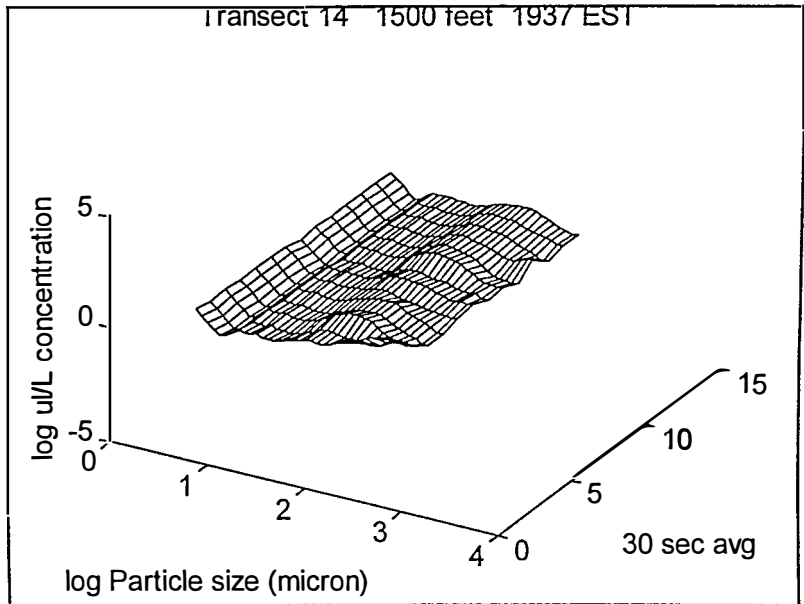
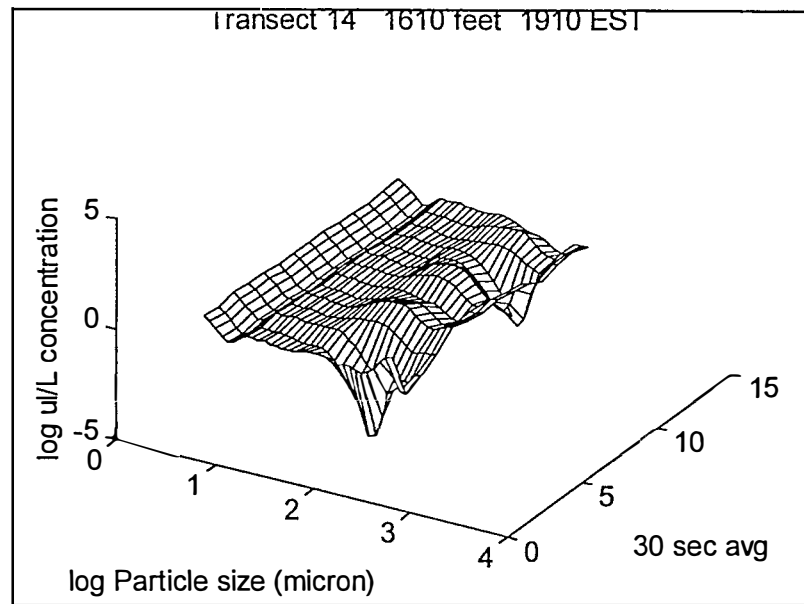
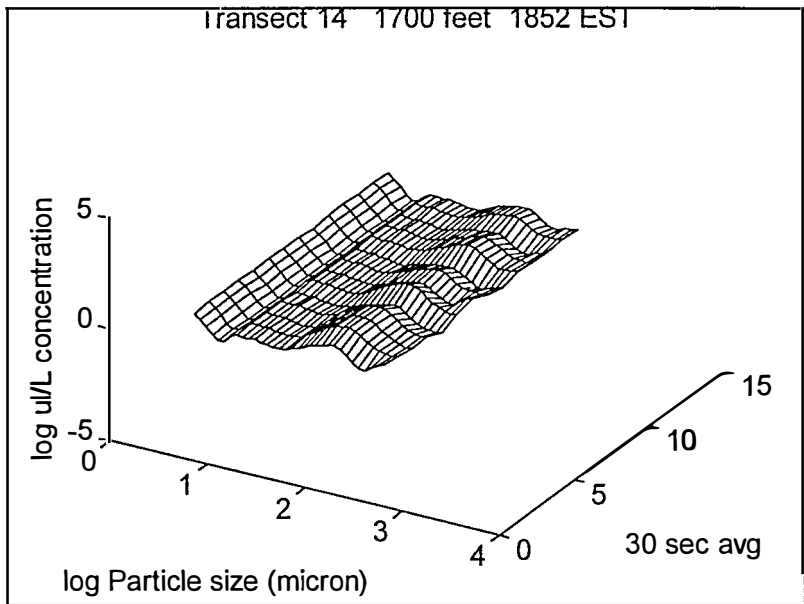

Transect 14 1250 feet 2028 EST

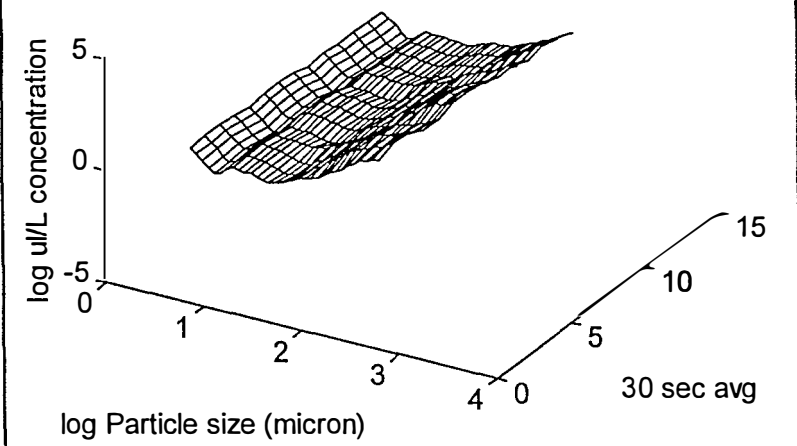

Transect 14 1120 feet 2047 EST

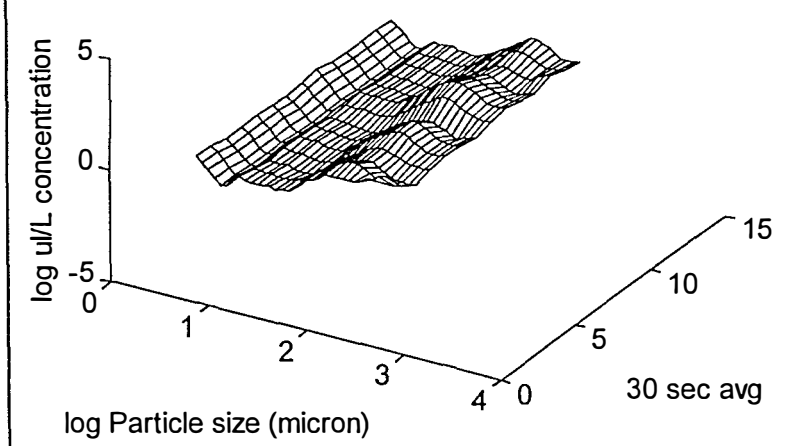

Transect 14 1040 feet 2104 EST

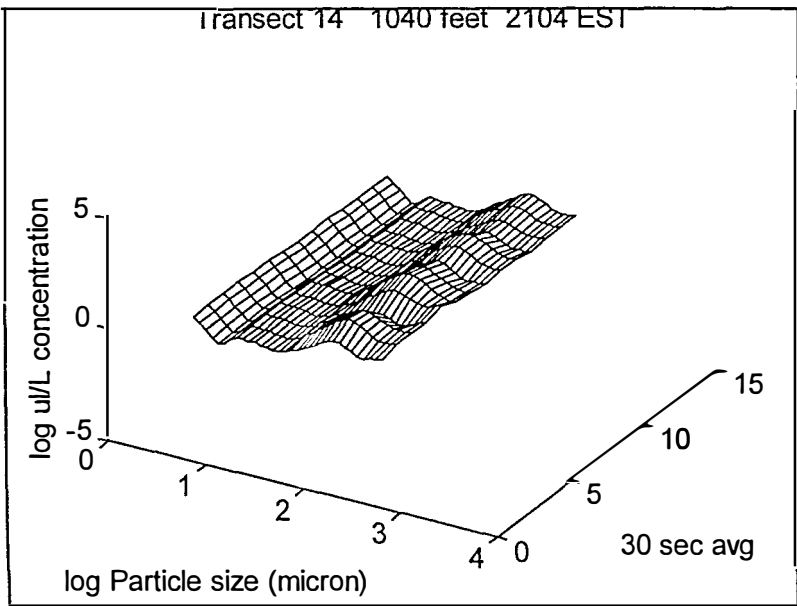

Transect 14 900 feet 2118 EST

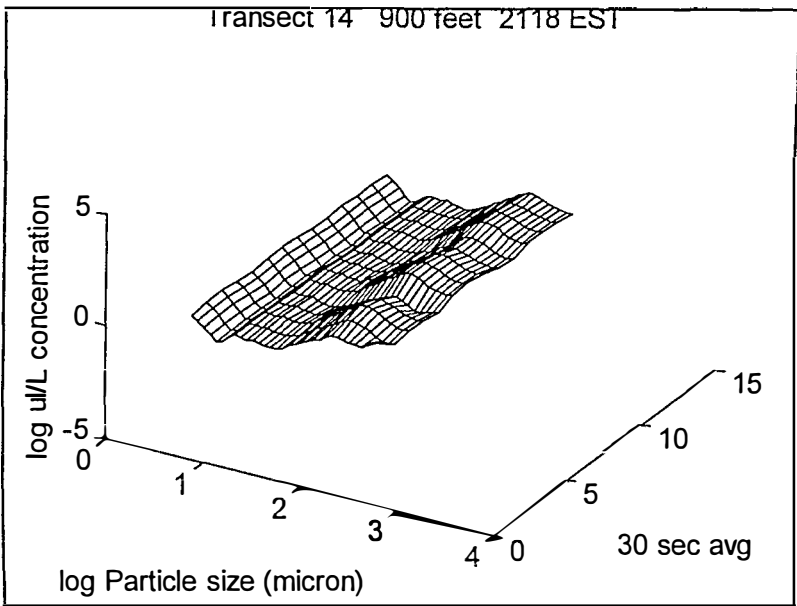

Transect 14 780 feet 2134 EST

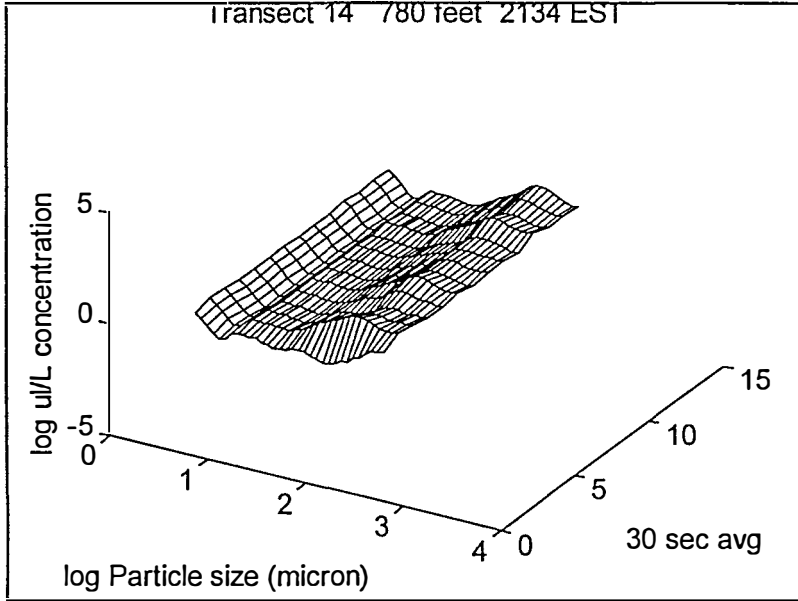

Transect 14 650 feet 2150 EST

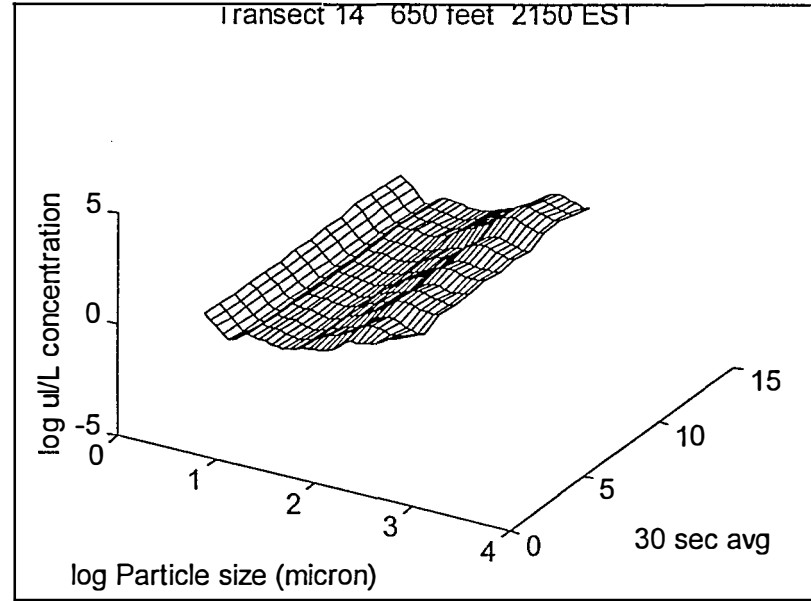

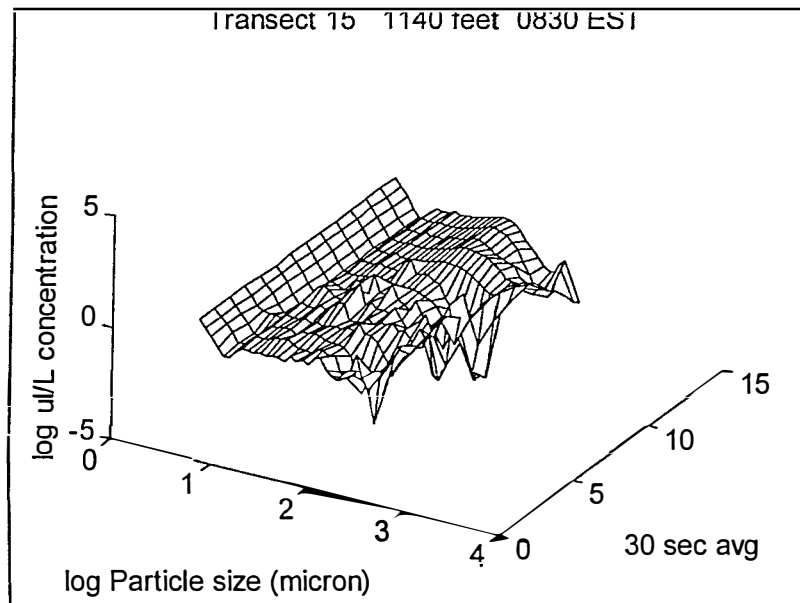
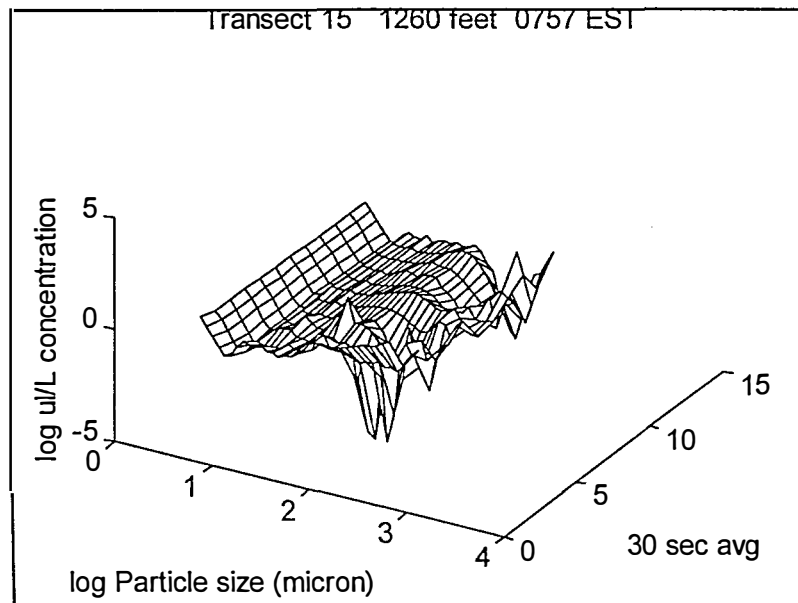
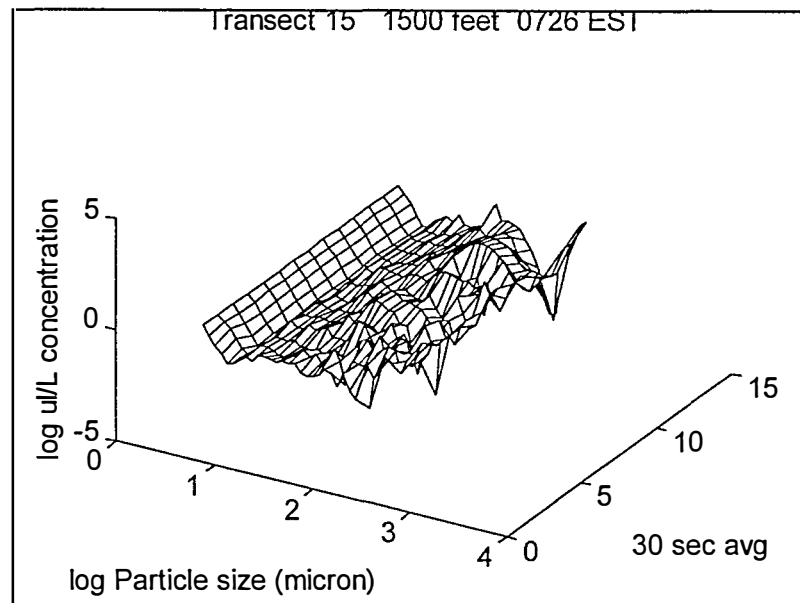
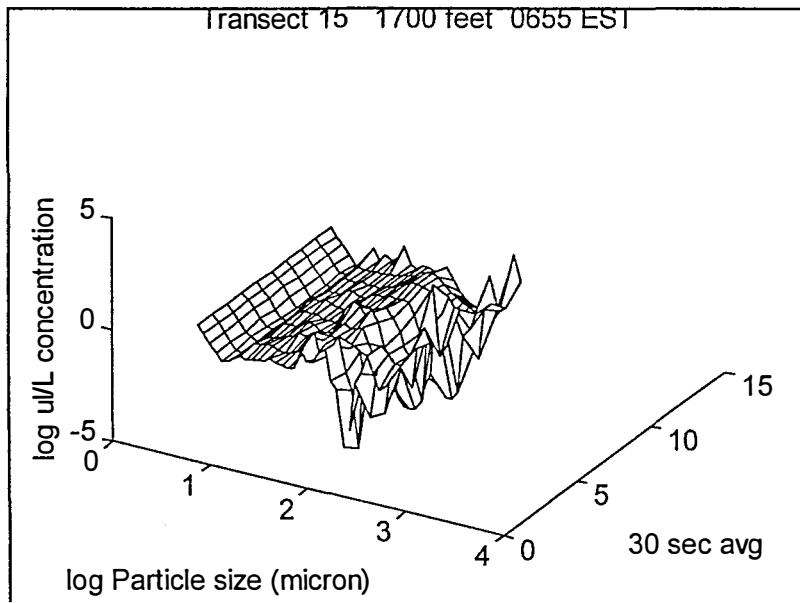

Transect 15 1050 feet 0859 EST

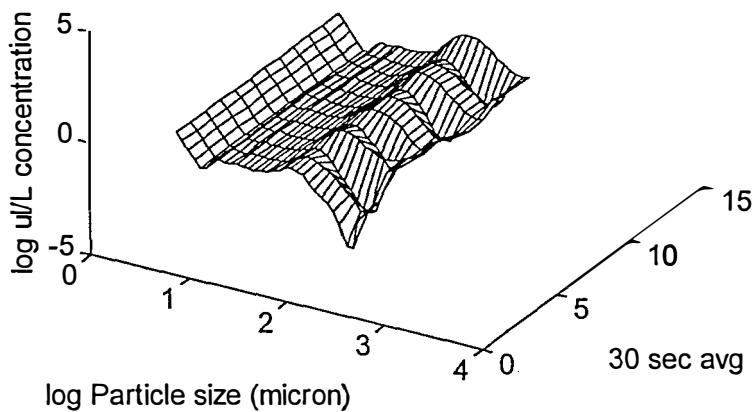

Transect 15 890 feet 0930 EST

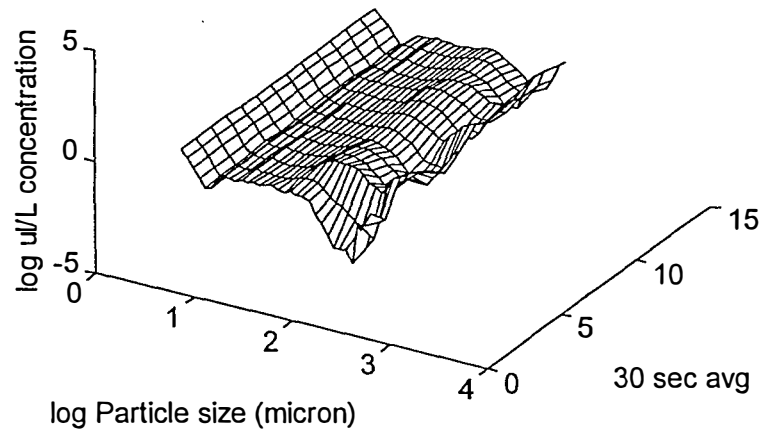

Transect 15 770 feet 1001 EST

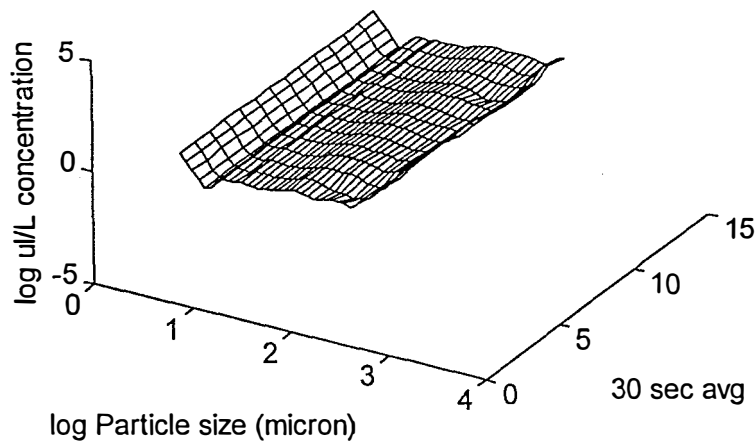

Transect 17 1730 feet 1919 EST

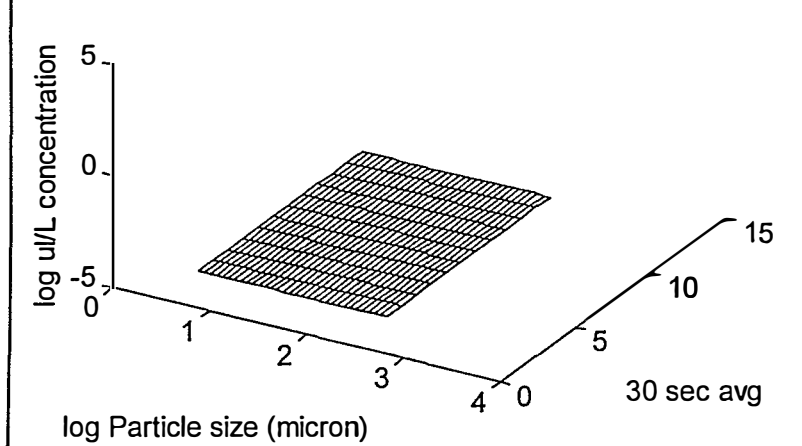

Transect 17 1610 feet 1934 EST

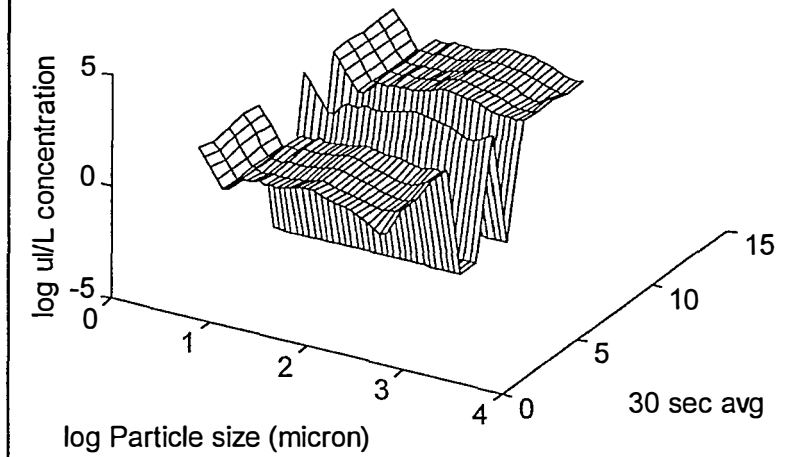

Transect 17 1490 feet 1952 EST

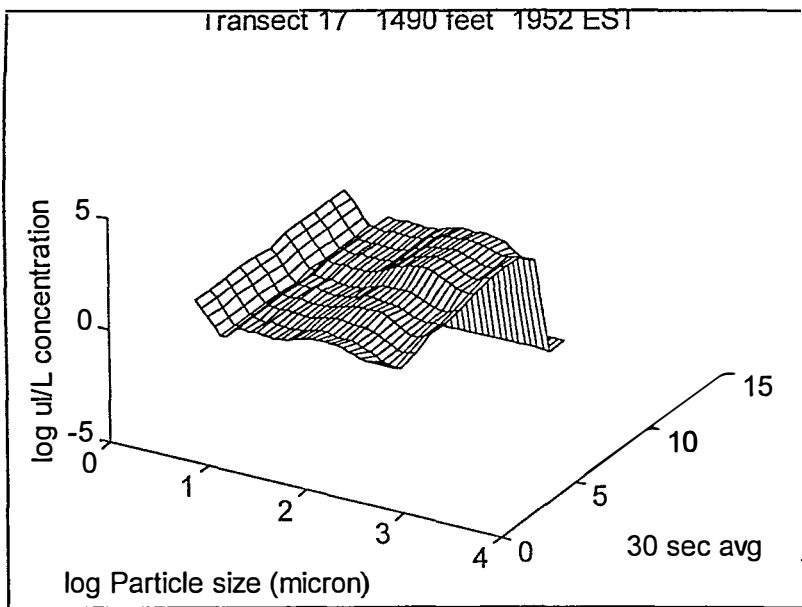

Transect 17 1350 feet 2009 EST

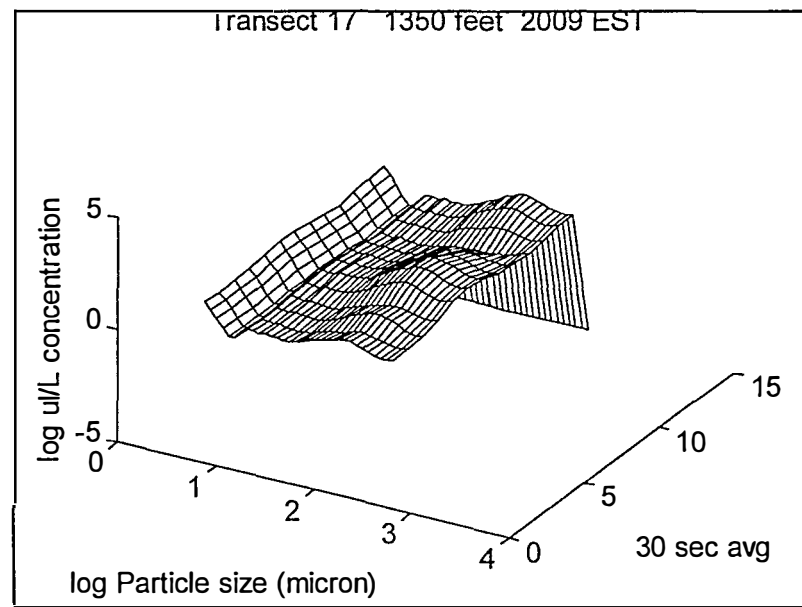

Transect 17 1250 feet 2026 EST

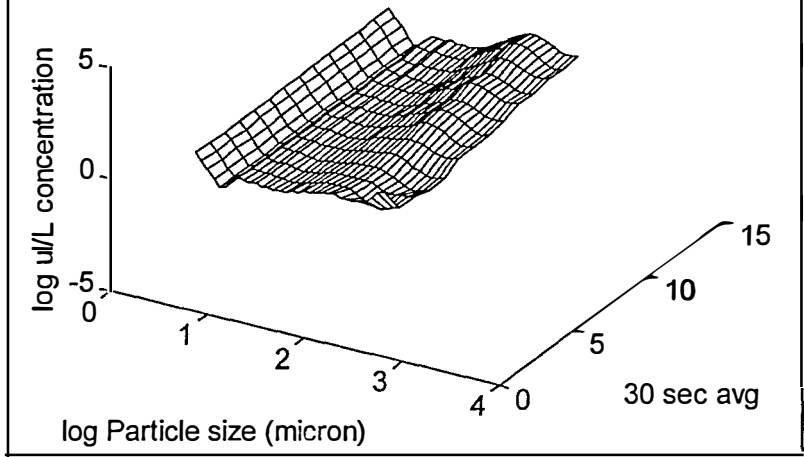

Transect 17 1050 feet 2113 EST

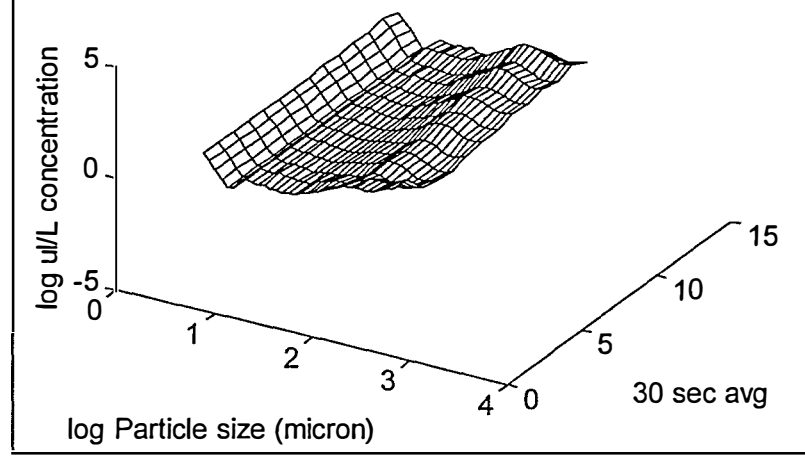

Transect 17 900 feet 2135 EST

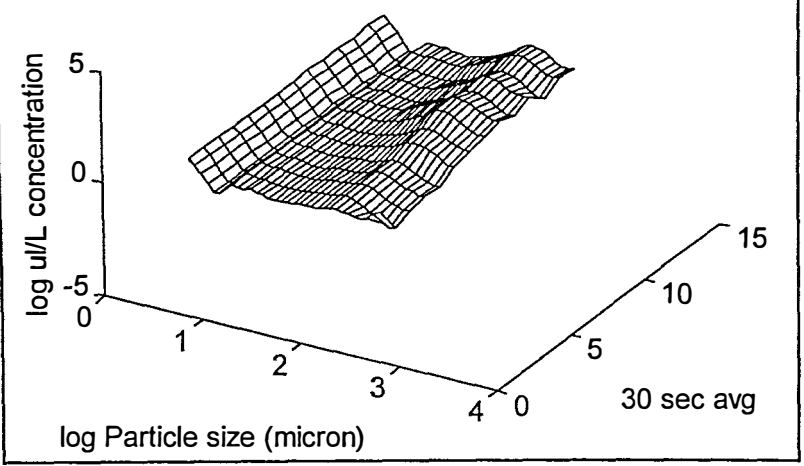

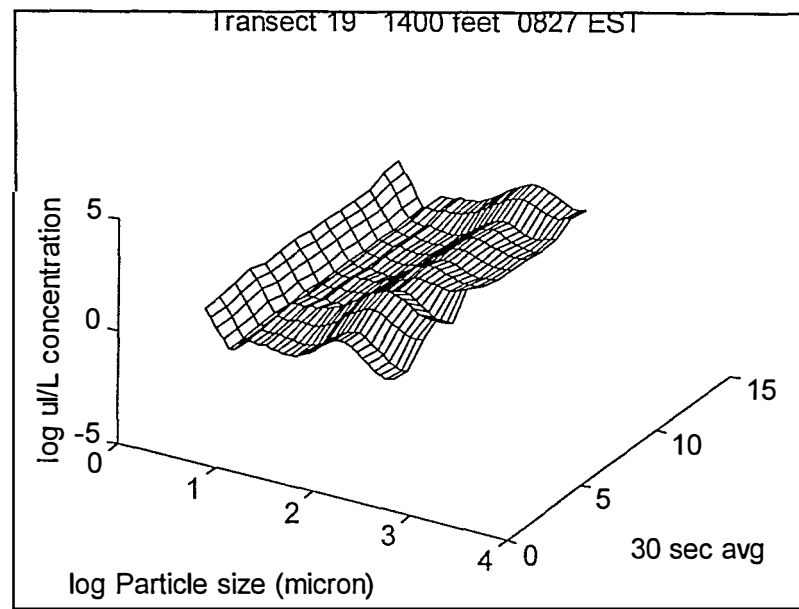
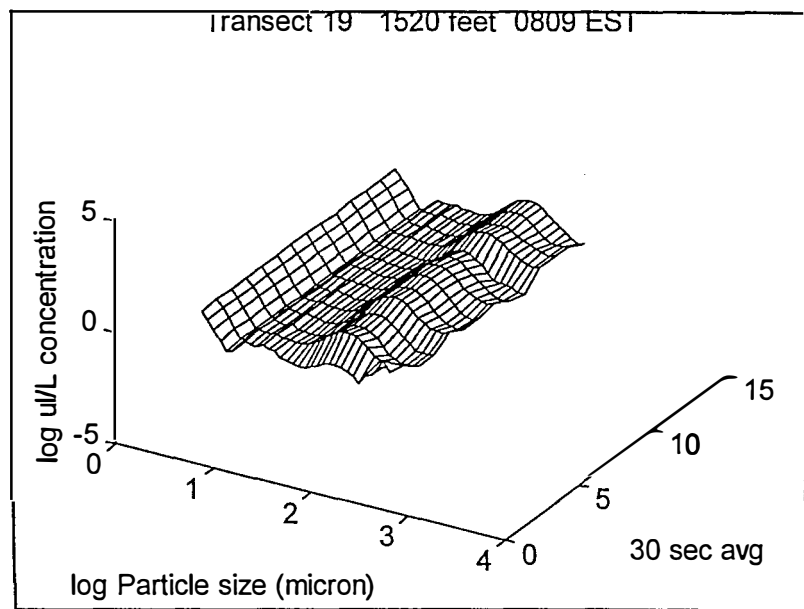
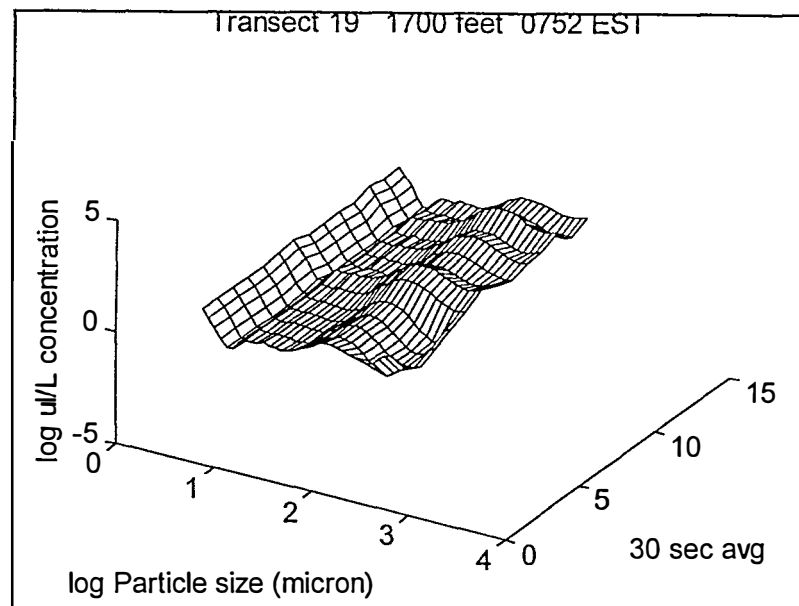
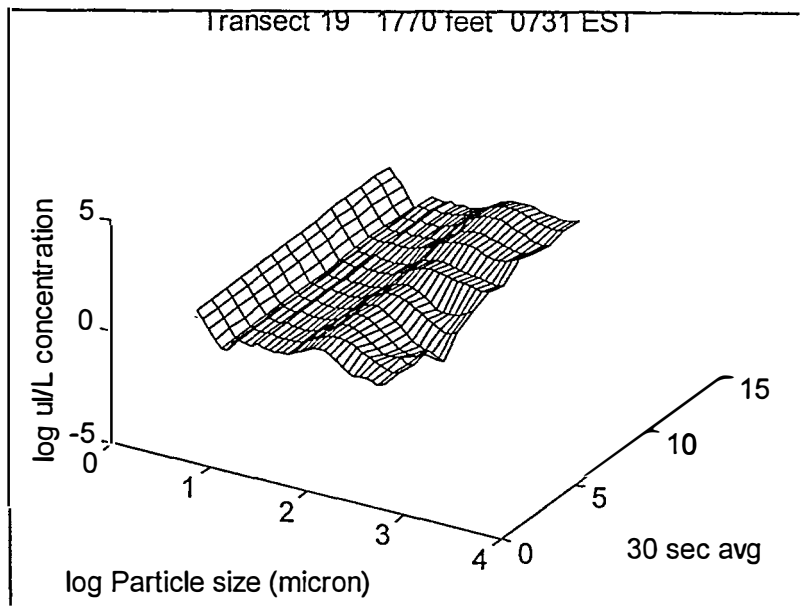

Transect 19 1260 feet 0847 EST

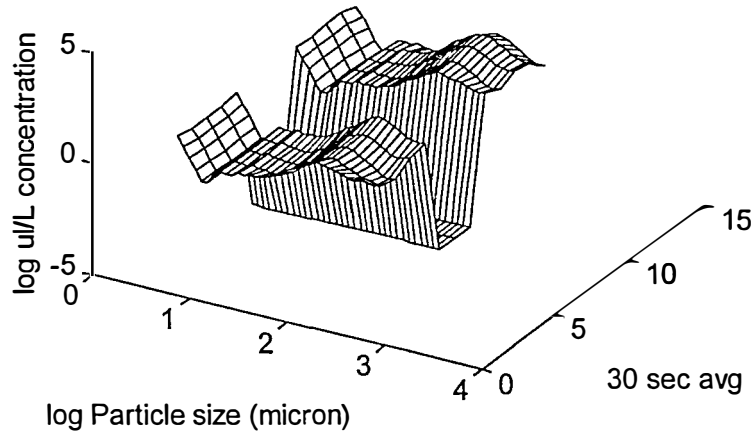

Transect 19 1140 feet 0904 EST

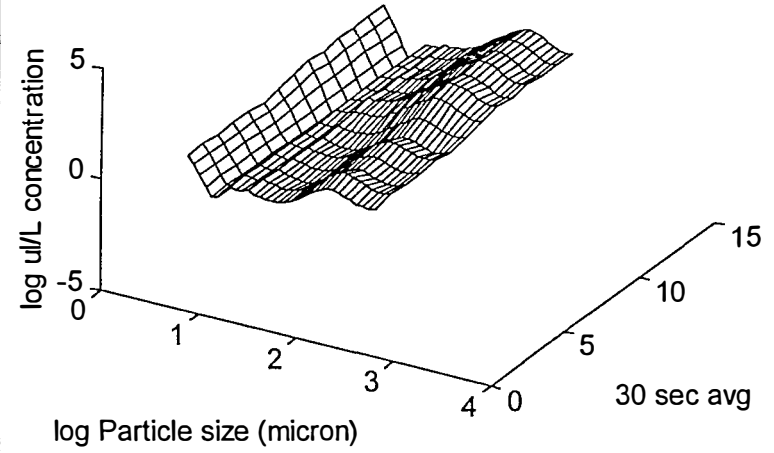

Transect 19 1050 feet 0922 EST

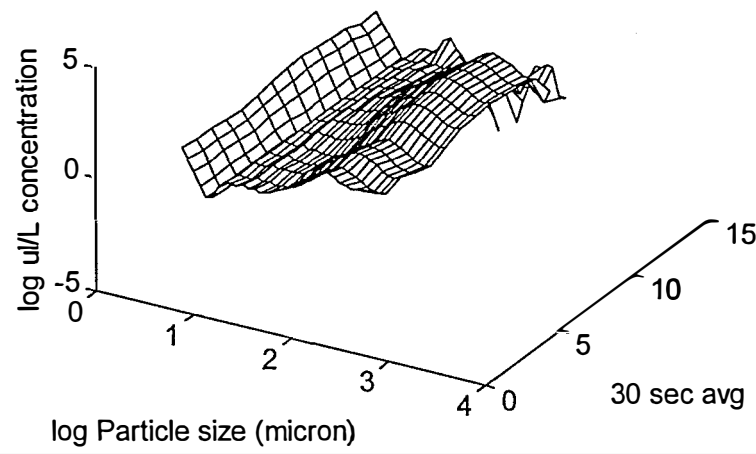

Transect 19 900 feet 0940 EST

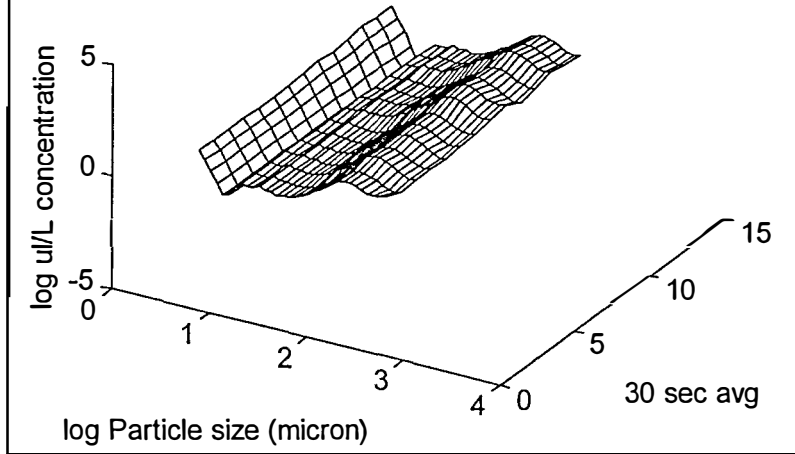

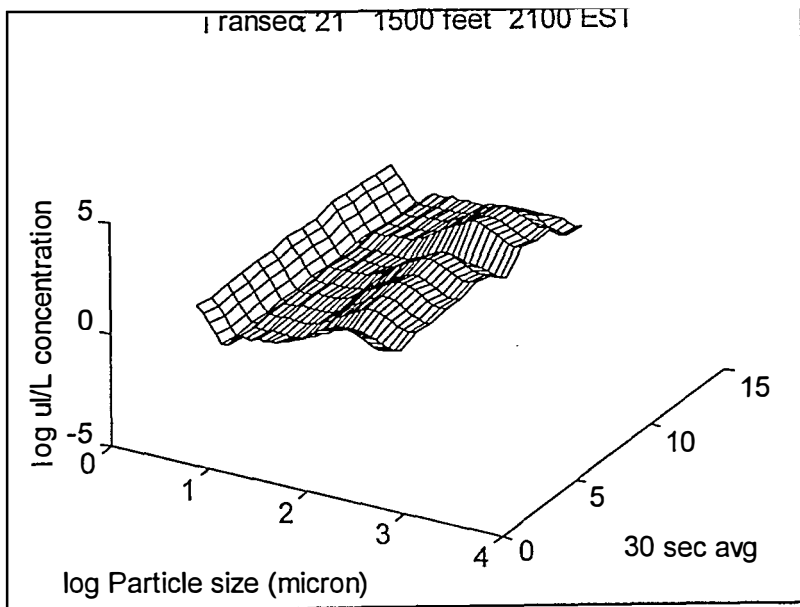
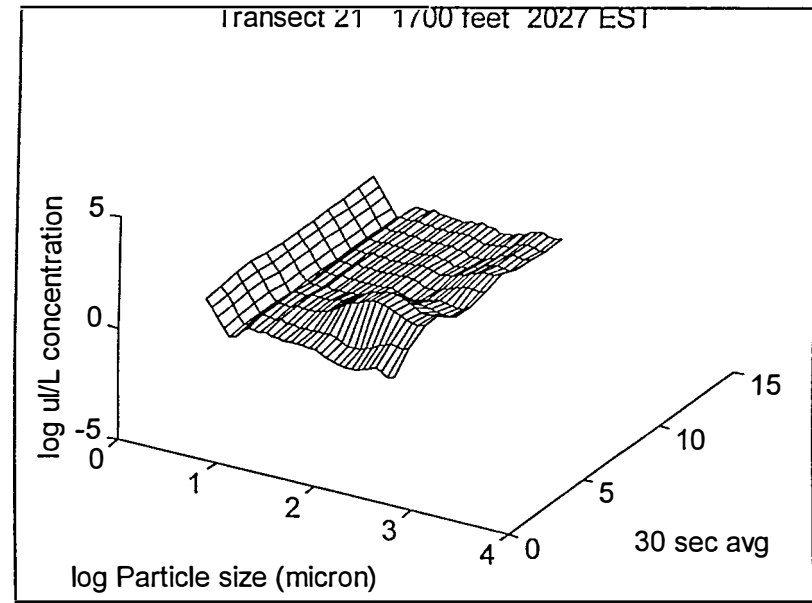
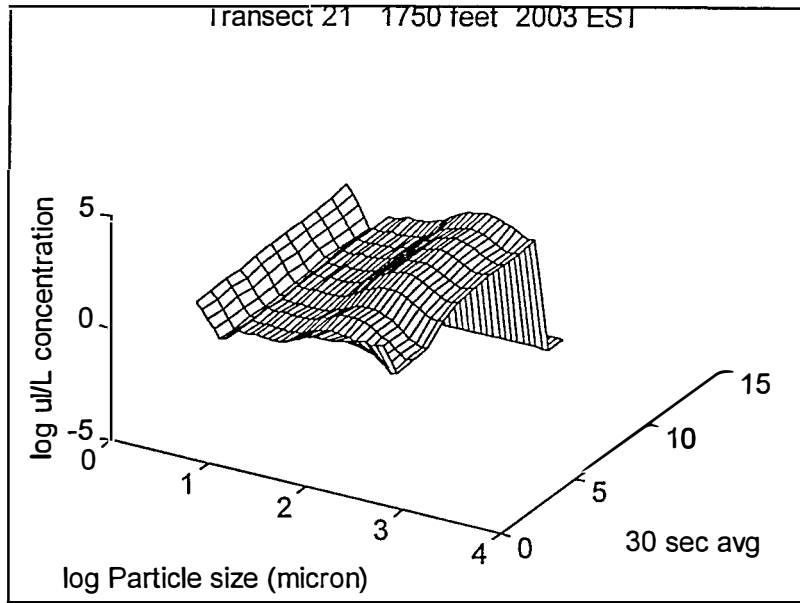

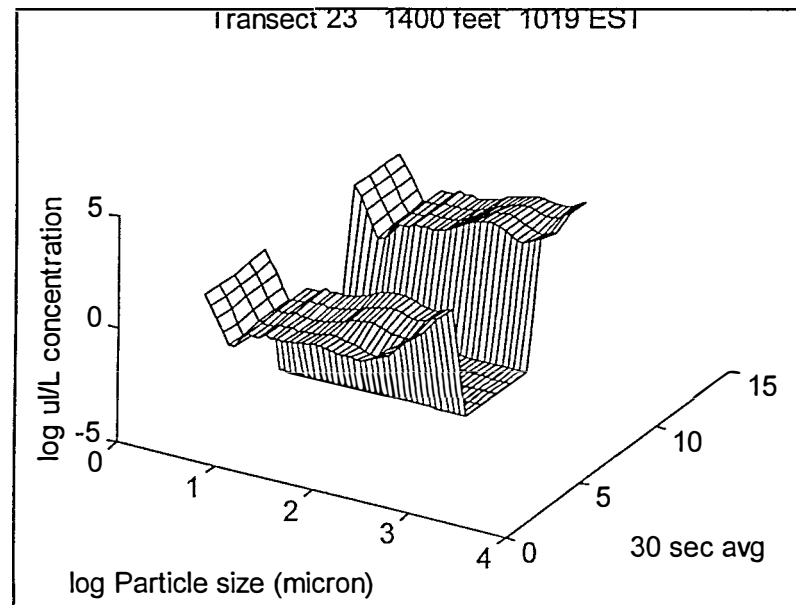
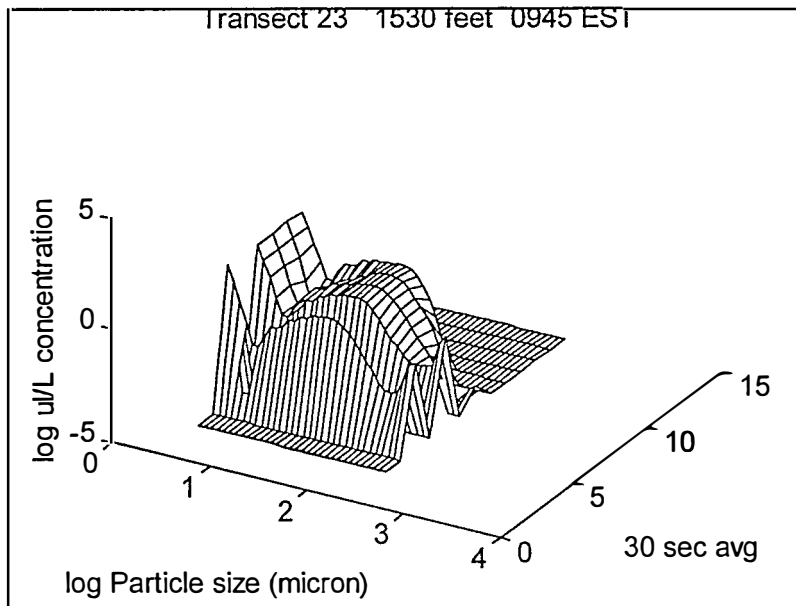
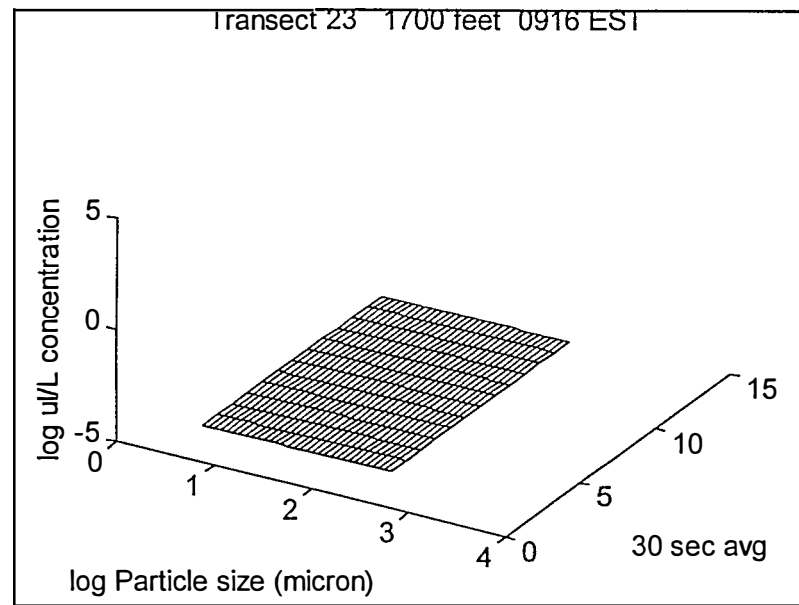
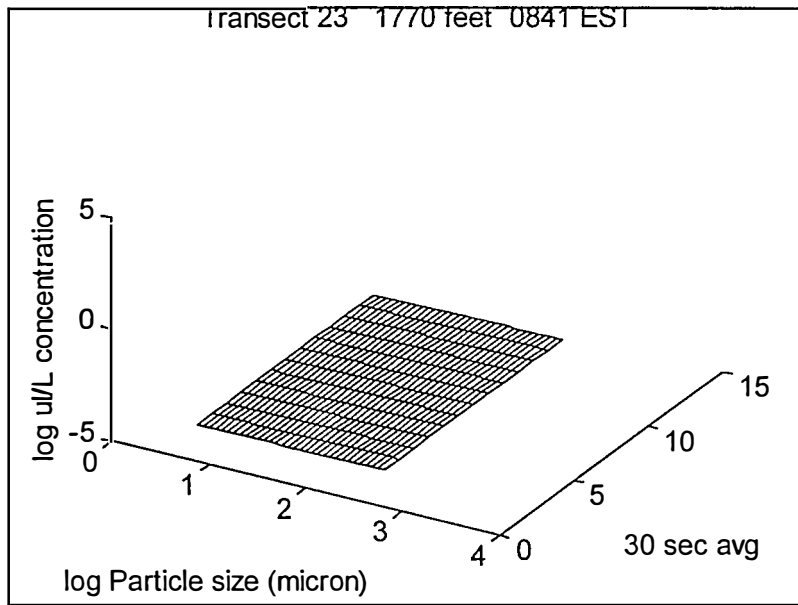

Transect 23 1140 feet 1137 ESI

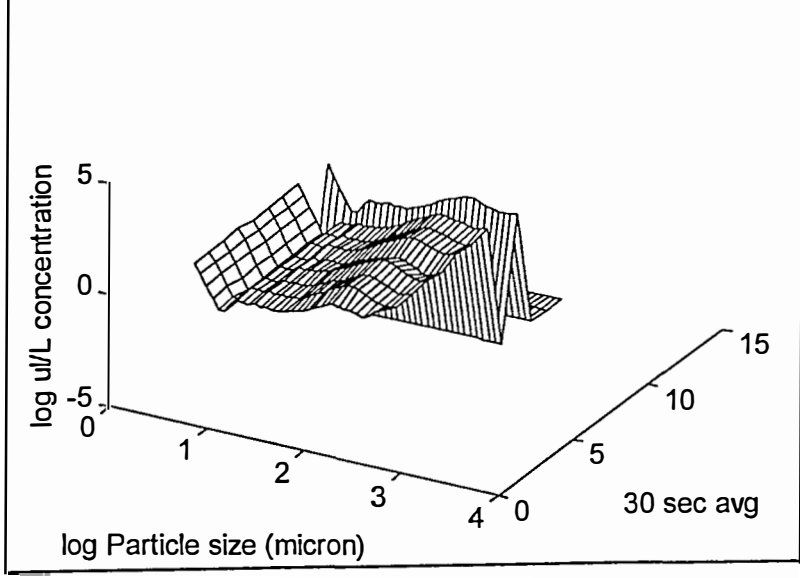

Transect 24 1610 feet 1536 EST

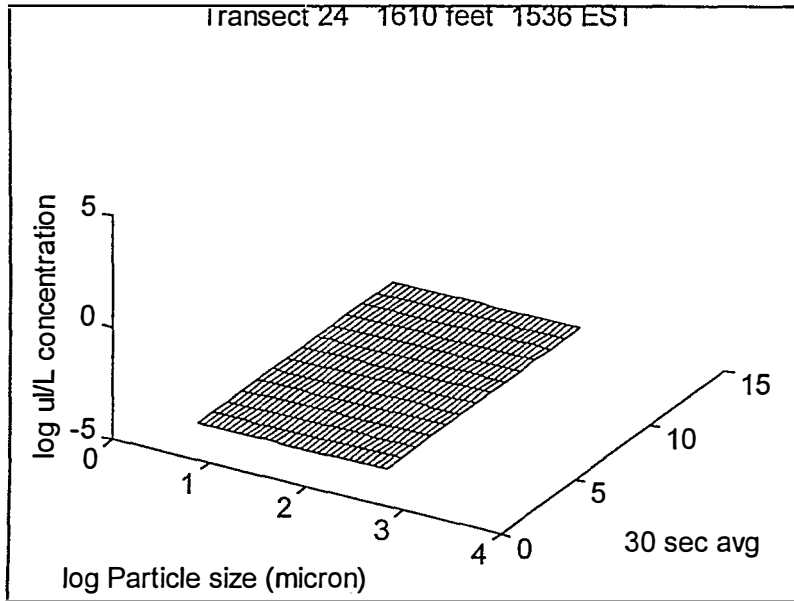

Transect 24 1500 feet 1551 EST

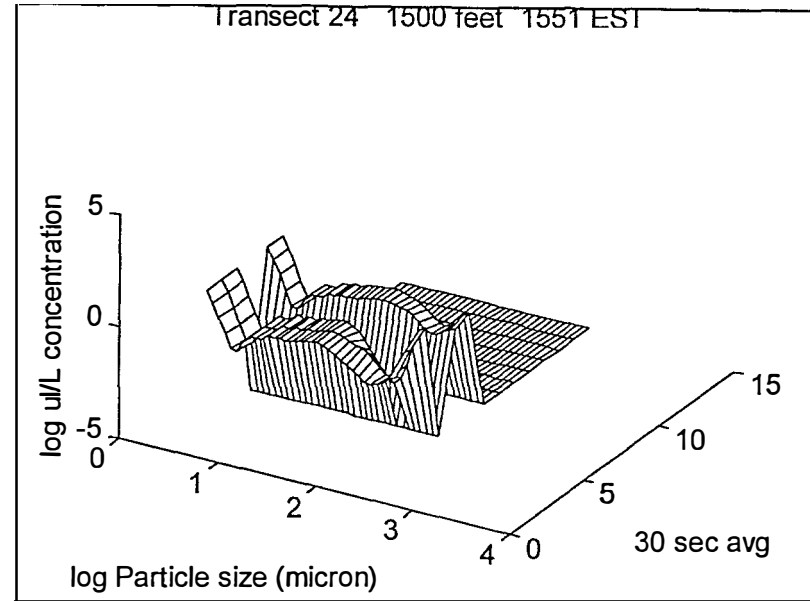

Transect 24 1380 feet 1611 EST

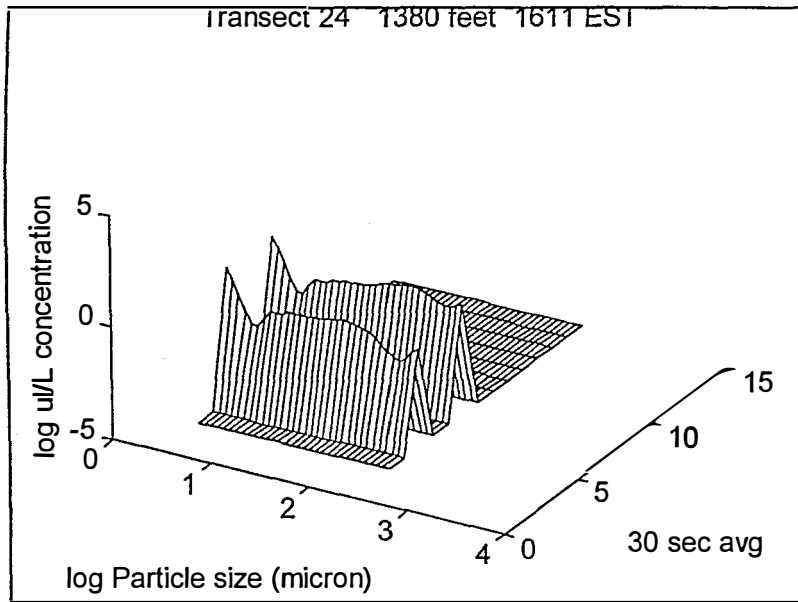

Transect 24 1260 feet 1628 EST

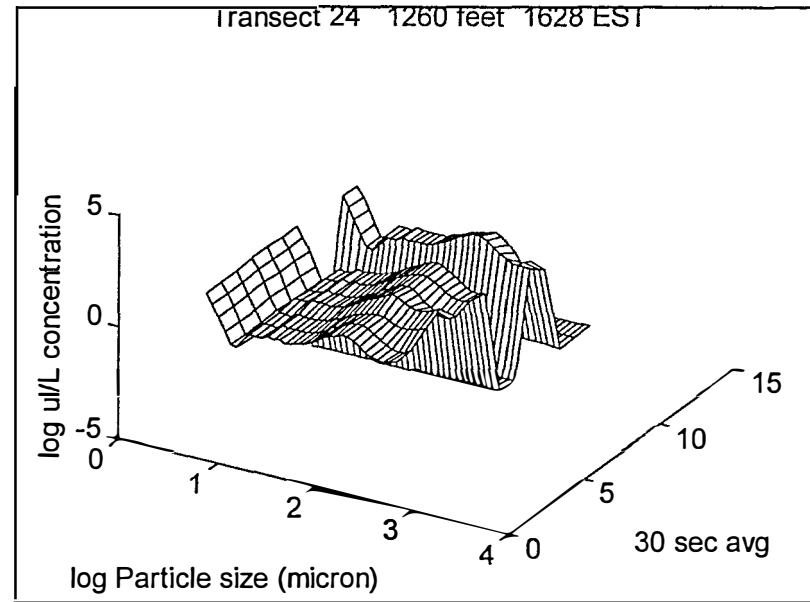

Transect 26 1760 feet 0942 EST

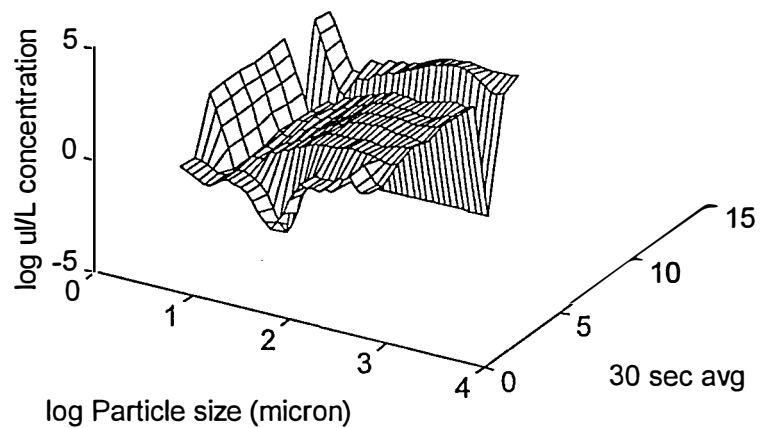

Transect 26 1700 feet 1053 EST

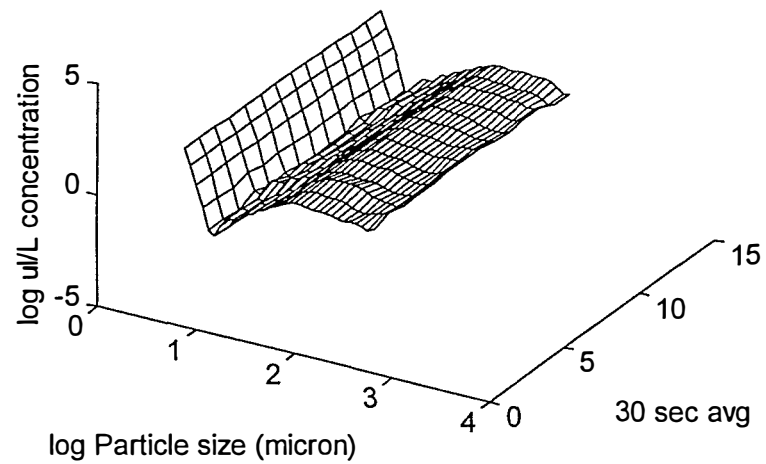

Transect 26 1520 feet 1115 EST

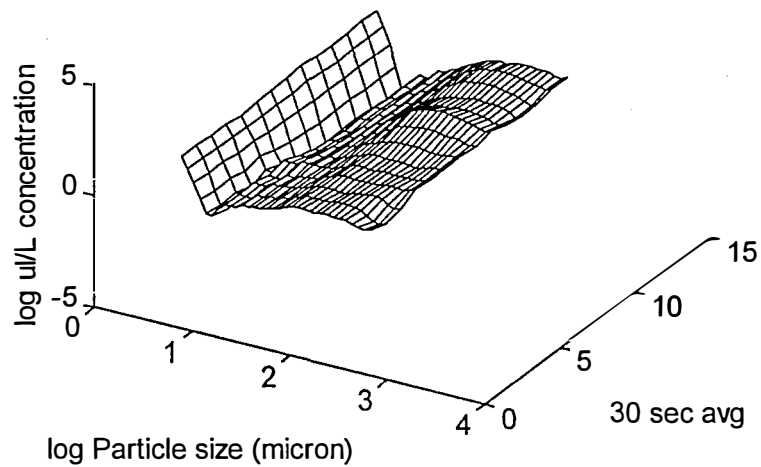

Transect 26 1280 feet 1134 EST

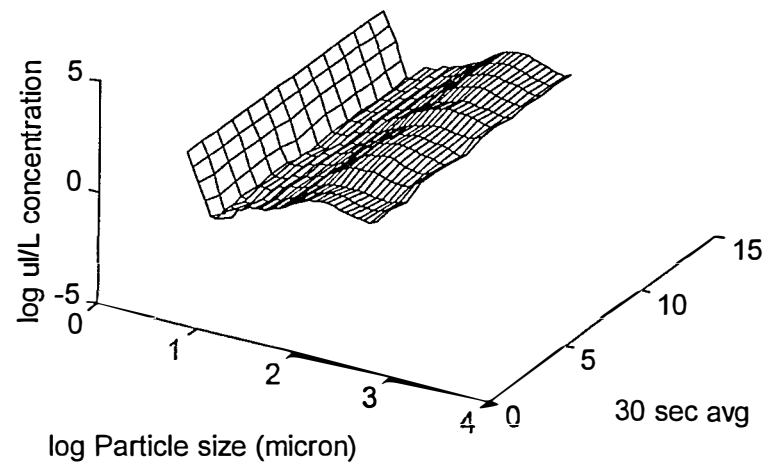

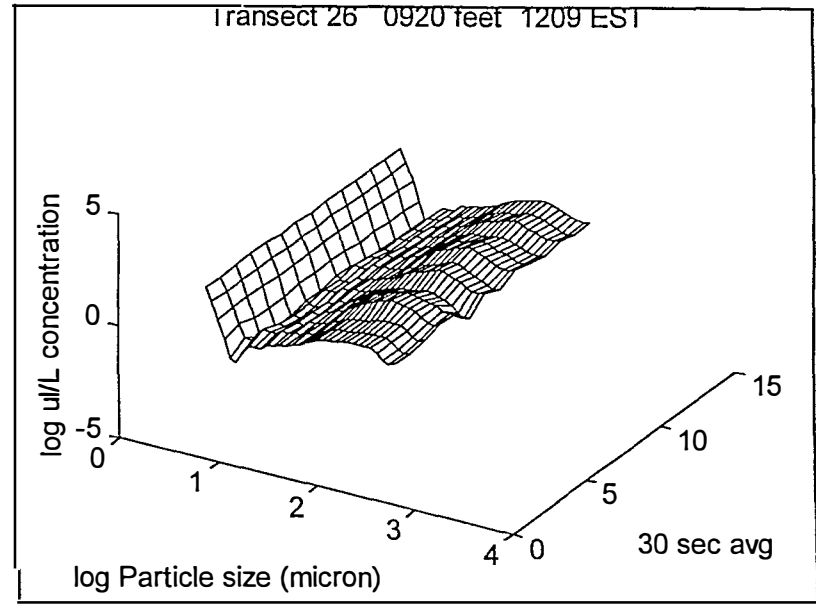
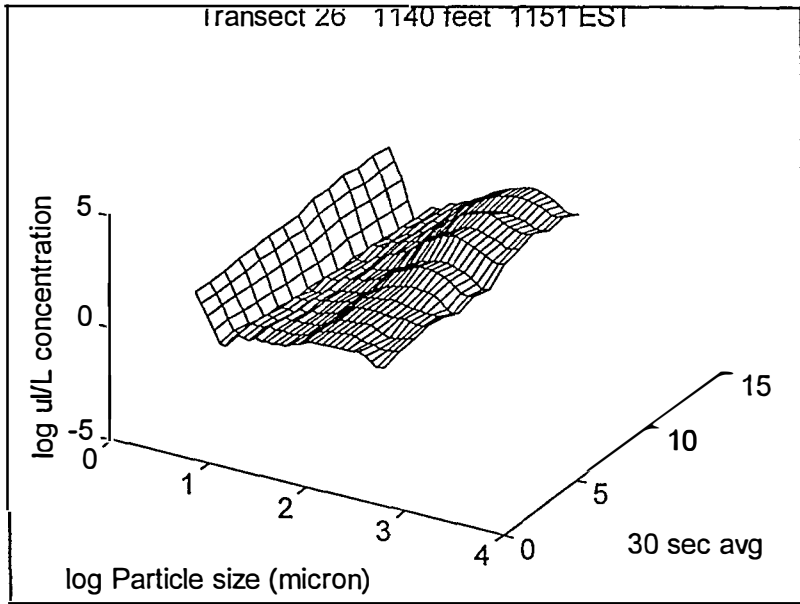

Transect 27 1700 feet 1615 EST

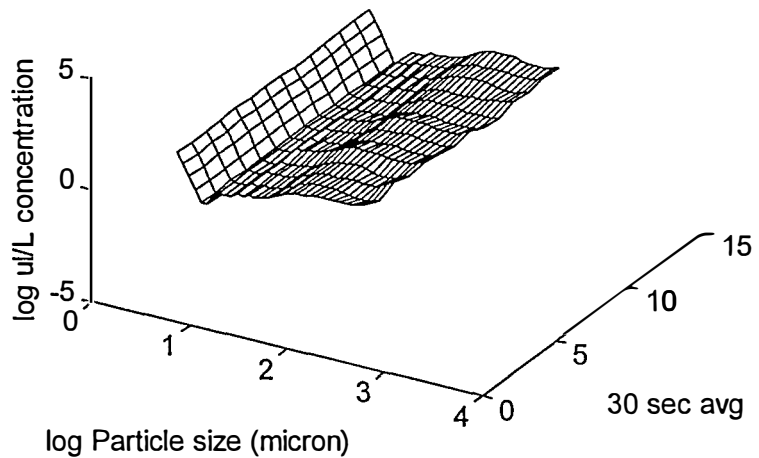

Transect 27 1610 feet 1636 EST

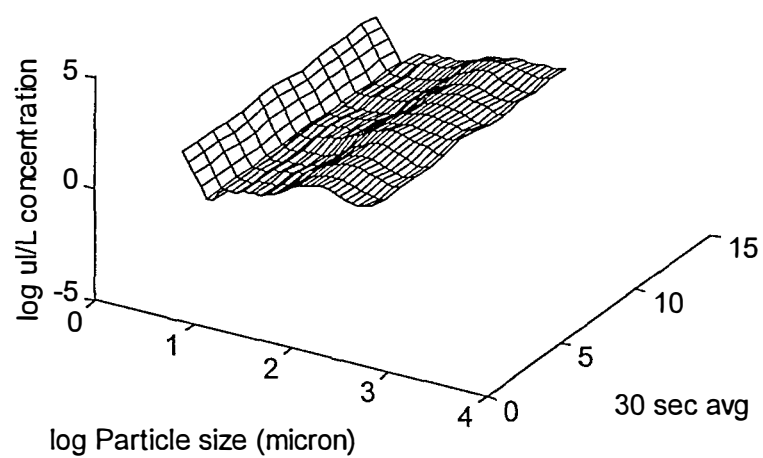

Transect 27 1500 feet 1652 EST

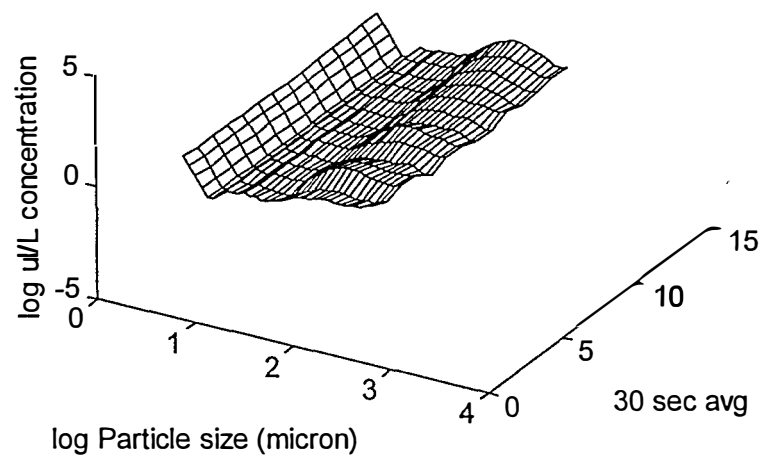

Transect 27 1370 feet 1711 EST

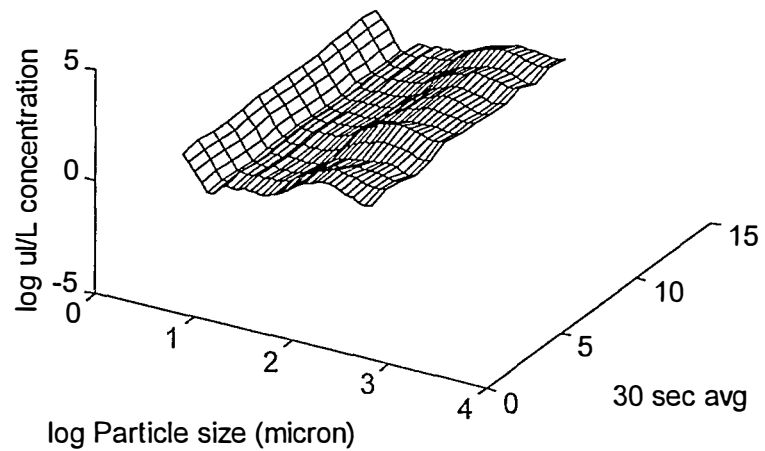

Transect 27 1250 feet 1735 EST

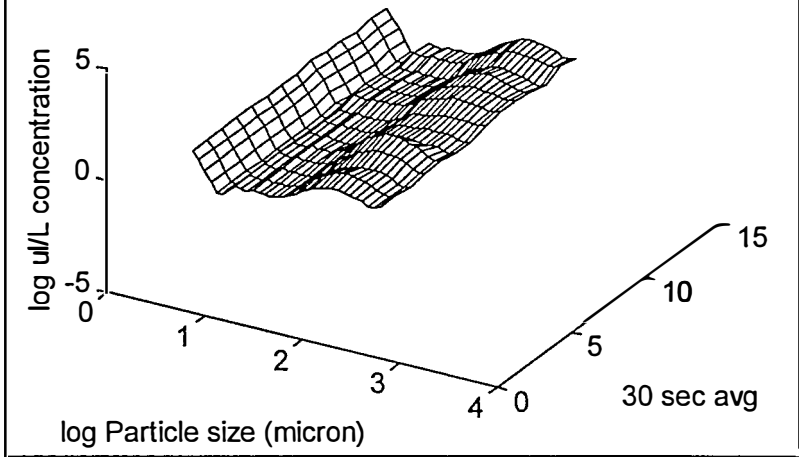

Transect 27 1130 feet 1753 EST

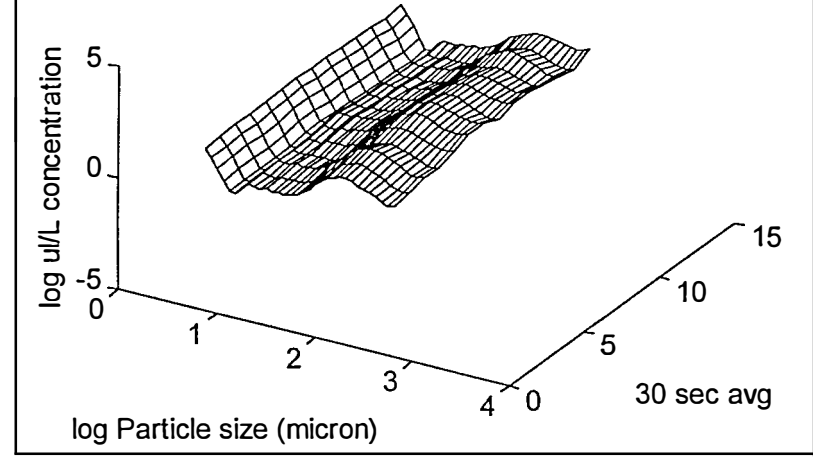

Transect 27 920 feet 1810 EST

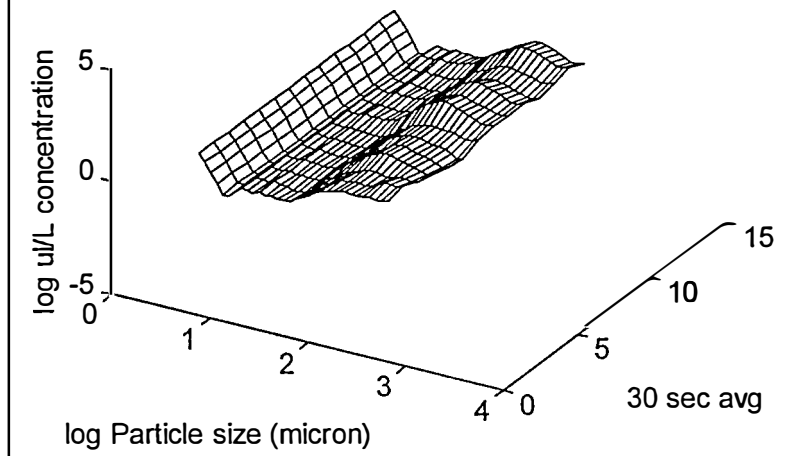

Transect 27 770 feet 1828 EST

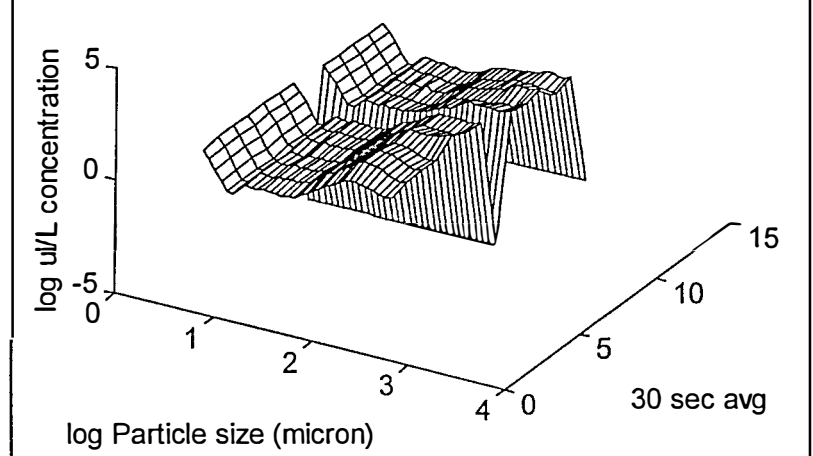

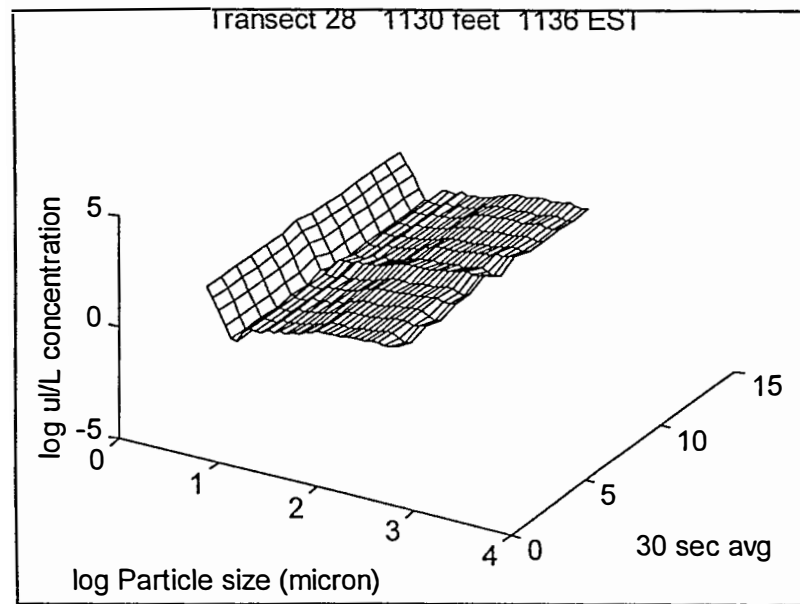
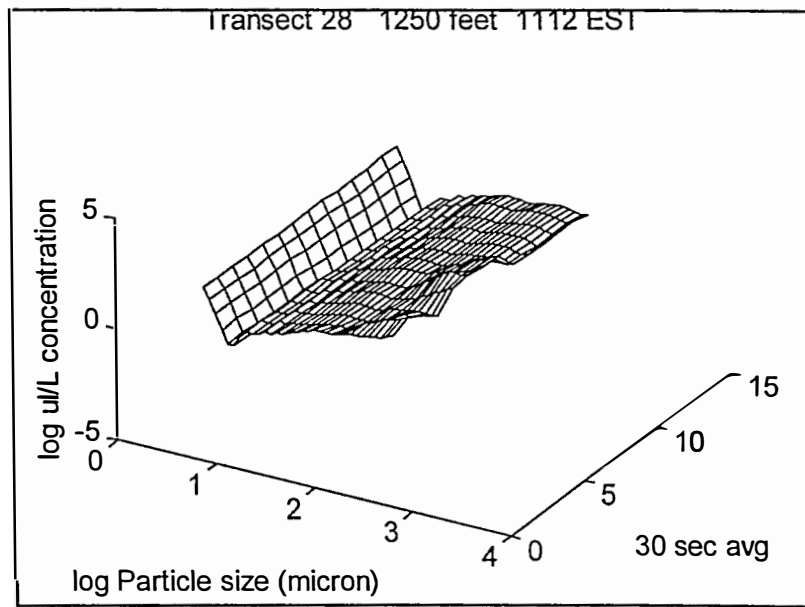
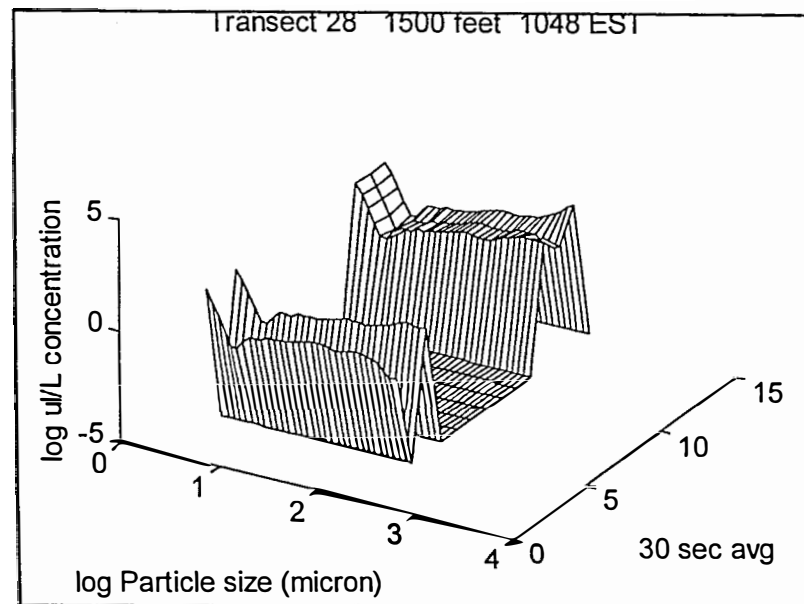
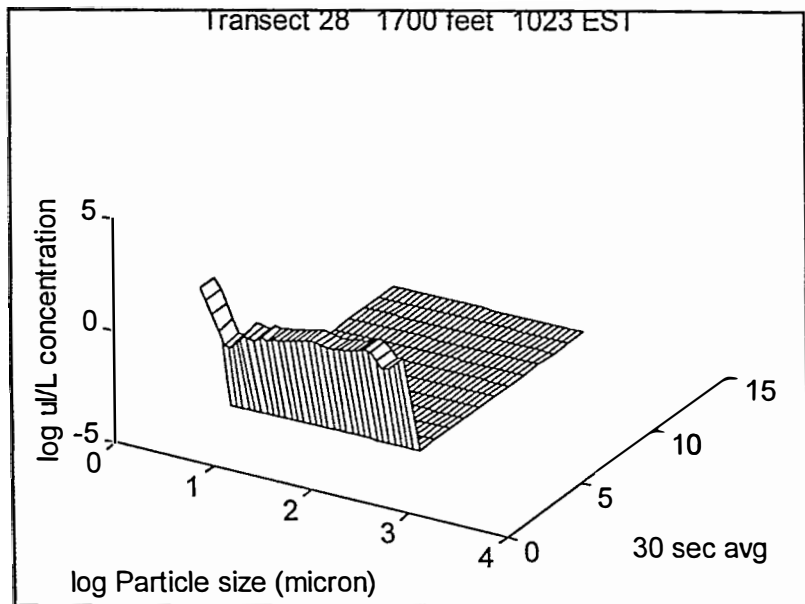

Transect 28 1050 feet 1201 EST

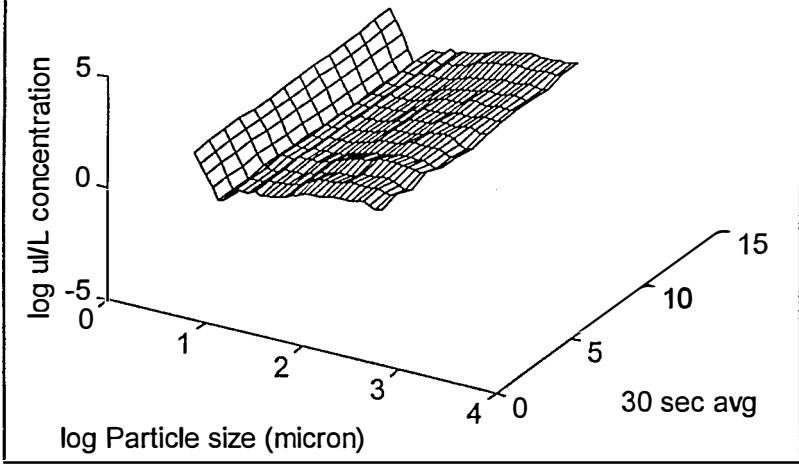

Transect 28 900 feet 1233 EST

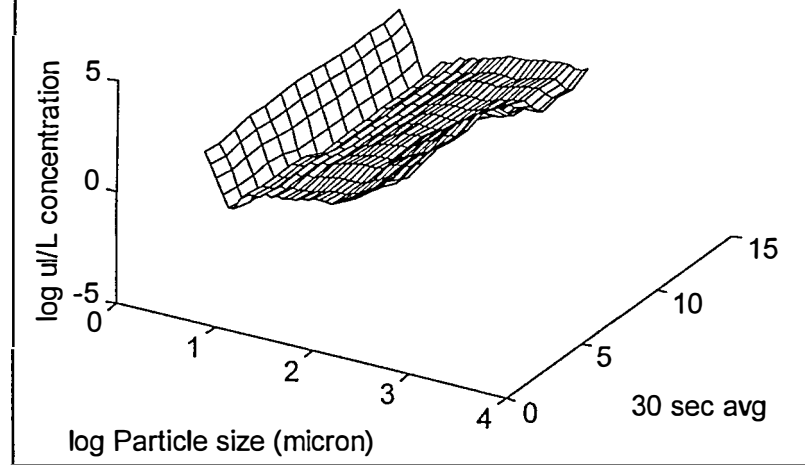

Transect 28 770 feet 1258 EST

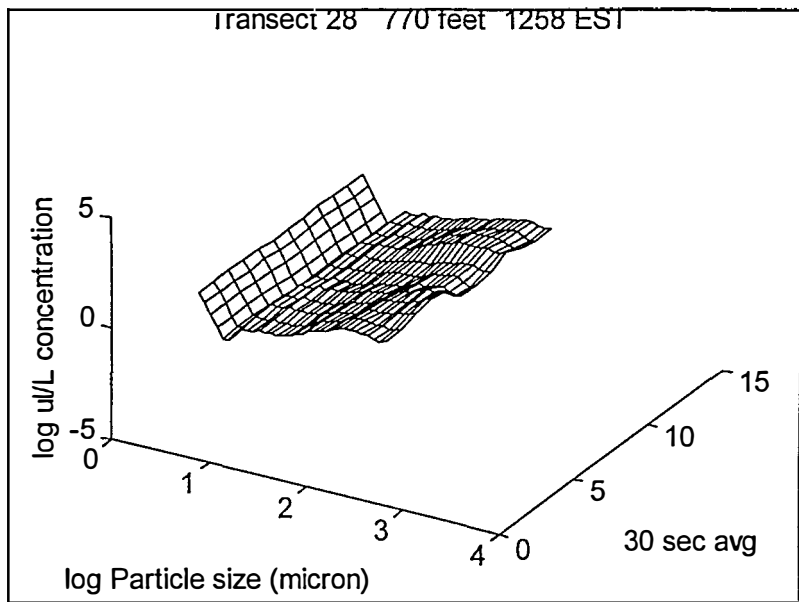

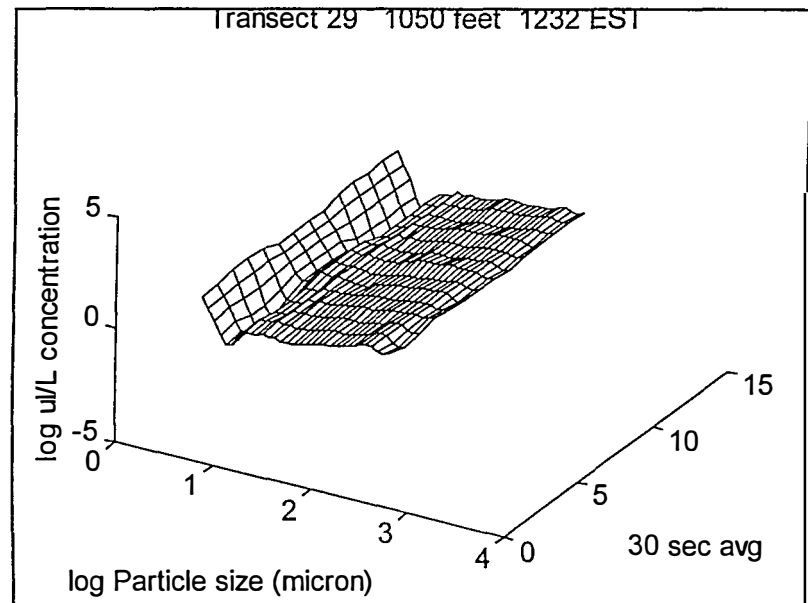
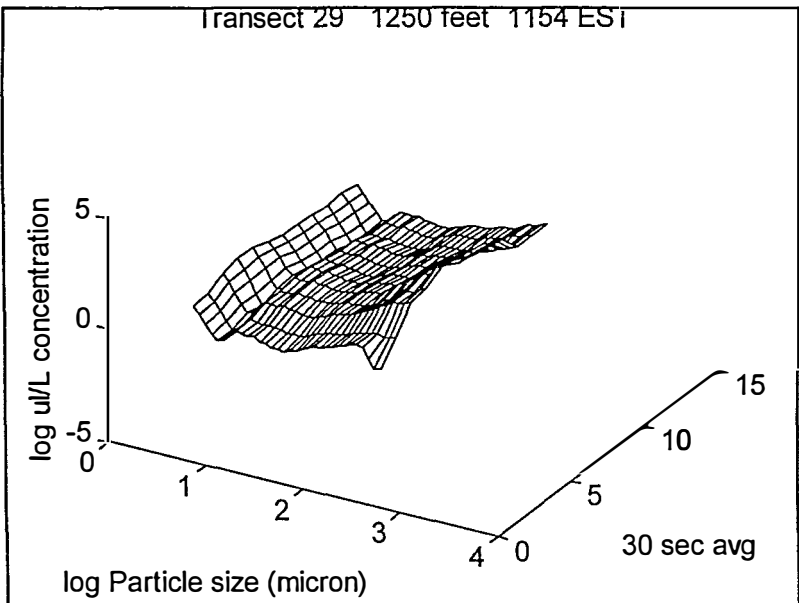
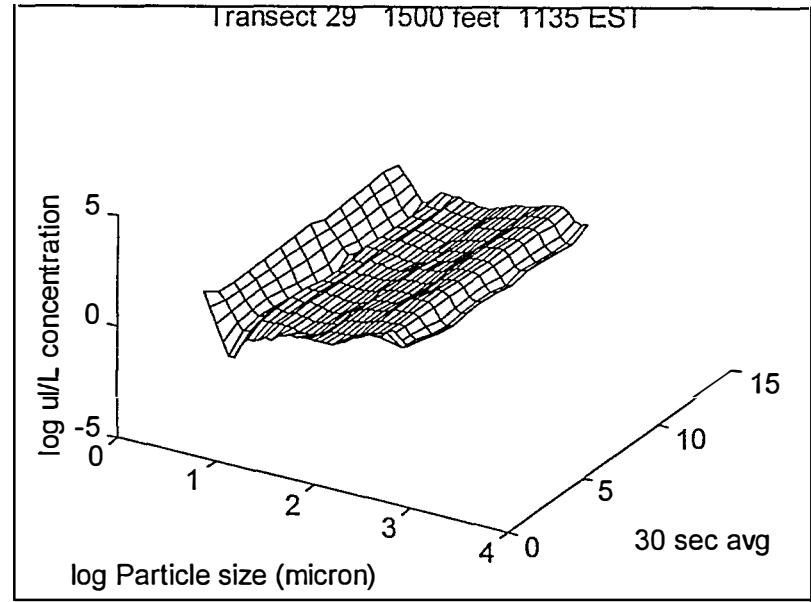
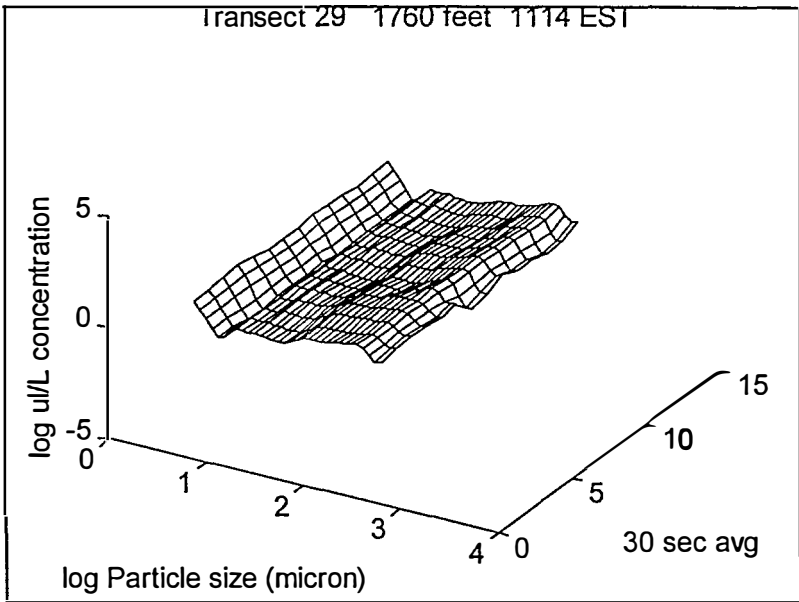

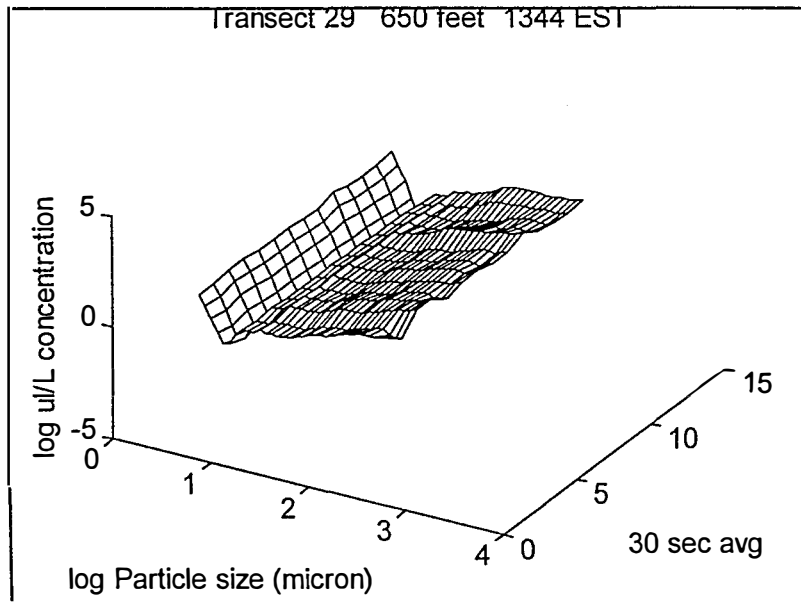
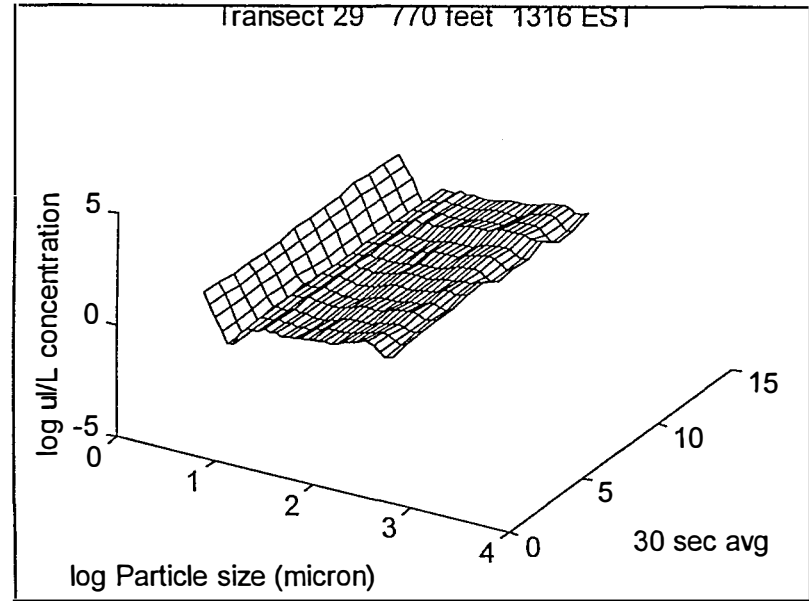
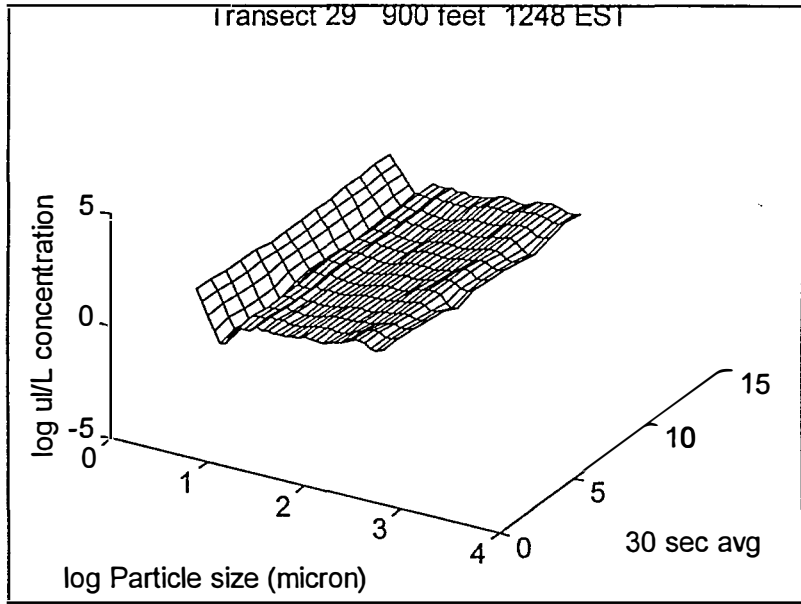

## Section 2

3 1/2 minute averages  
of LISST Time Series  
for each Transect  
as a function of Station

Average Station Concentration (1st half) Transect 1

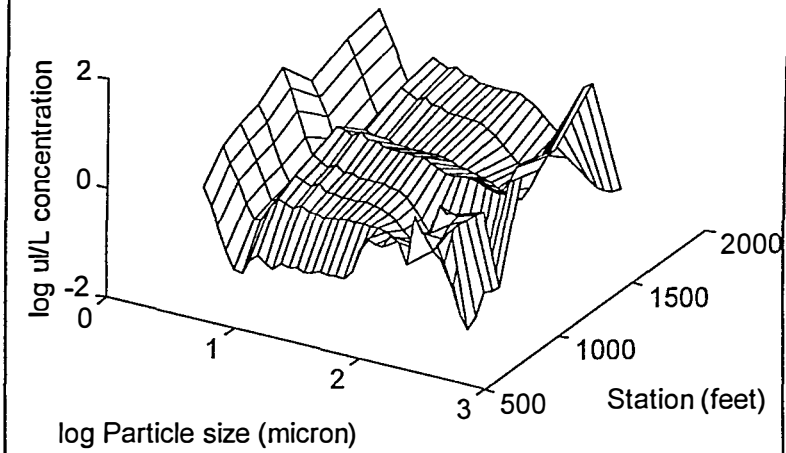

Average Station Concentration (2nd half) Transect 1

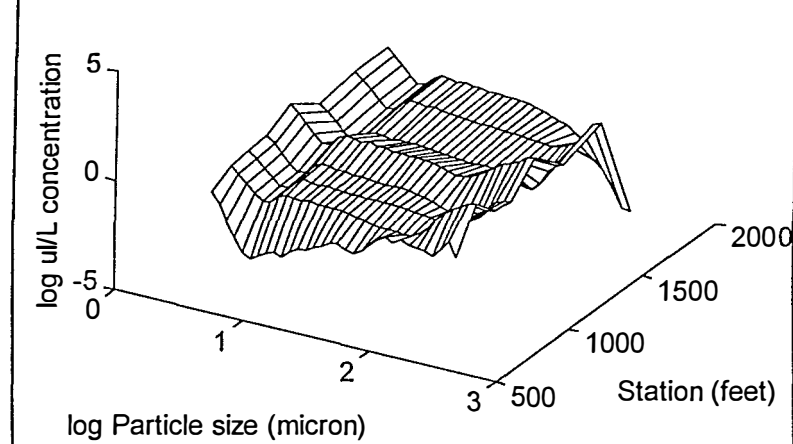

Average Station Concentration (1st half) Transect 2

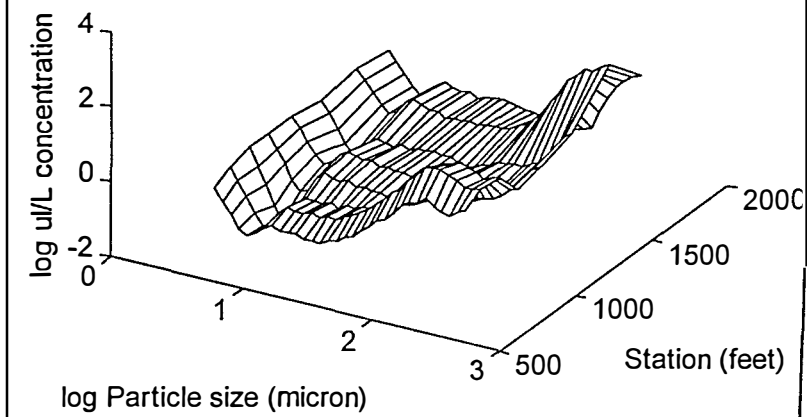

Average Station Concentration (2nd half) Transect 2

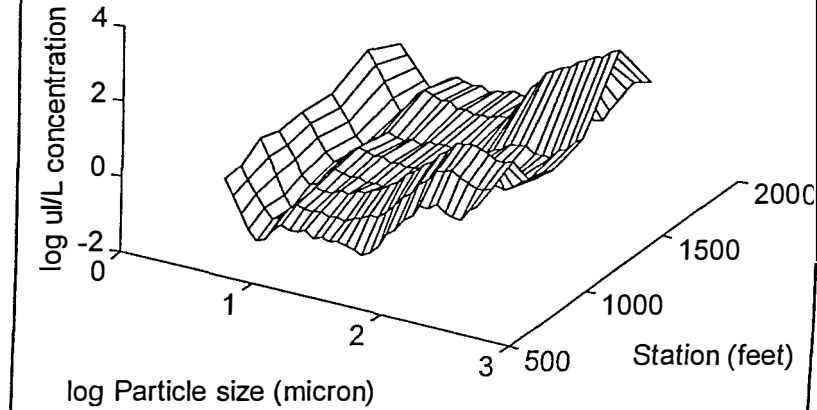

Average Station Concentration (1st half) Transect 3

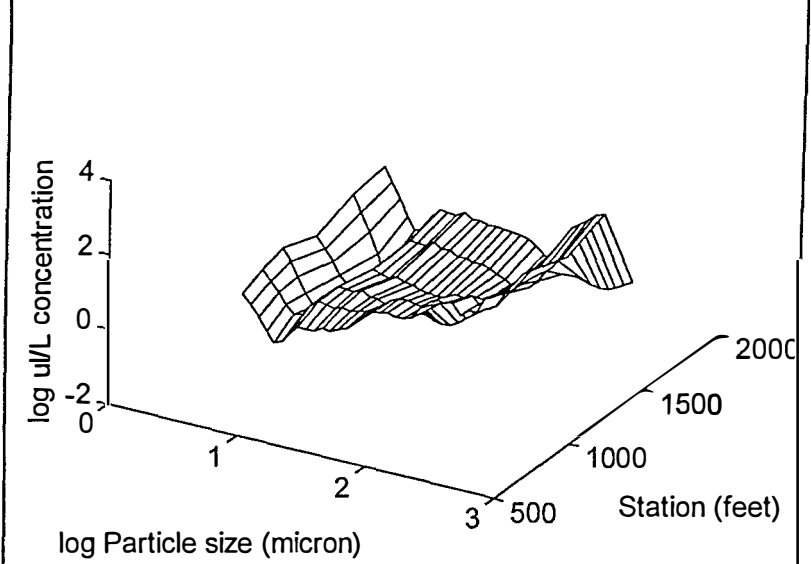

Average Station Concentration (2nd half) Transect 3

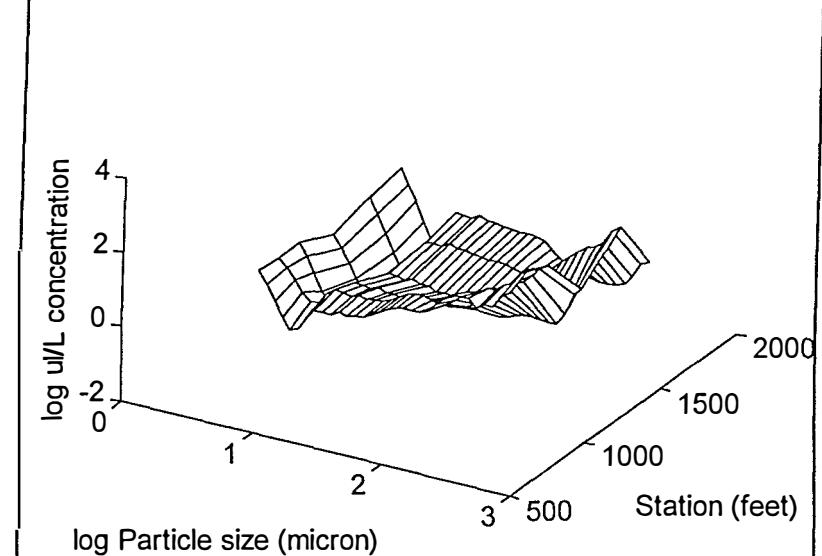

Average Station Concentration (1st half) Transect 4

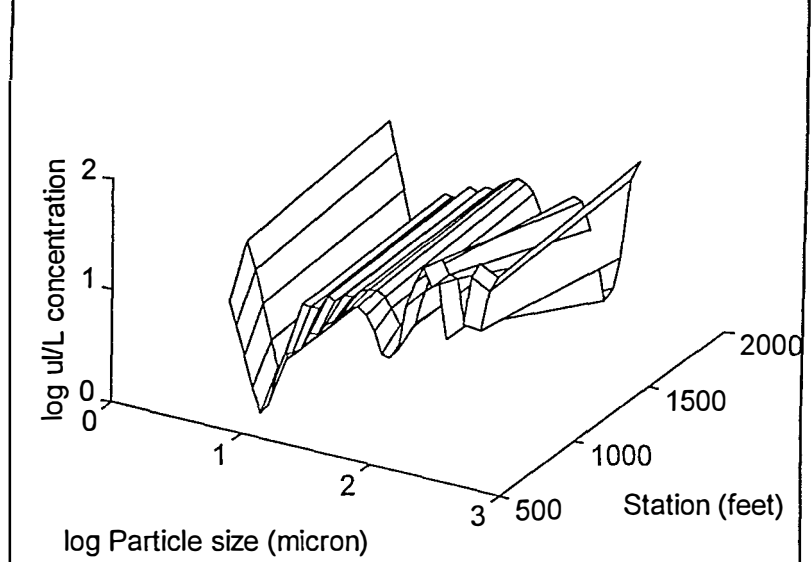

Average Station Concentration (2nd half) Transect 4

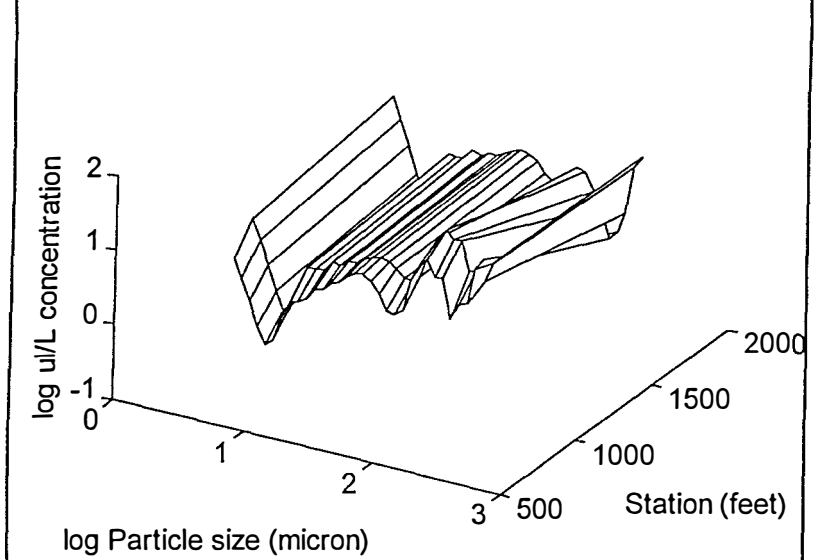

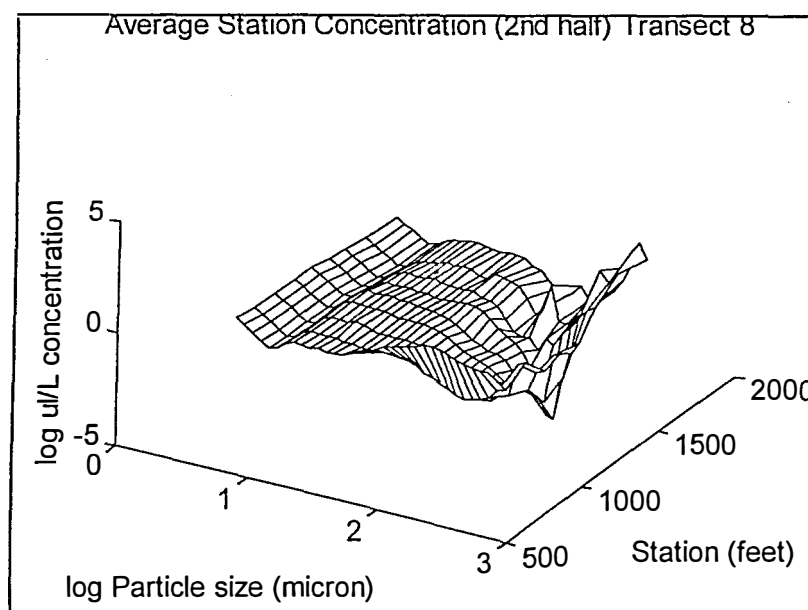
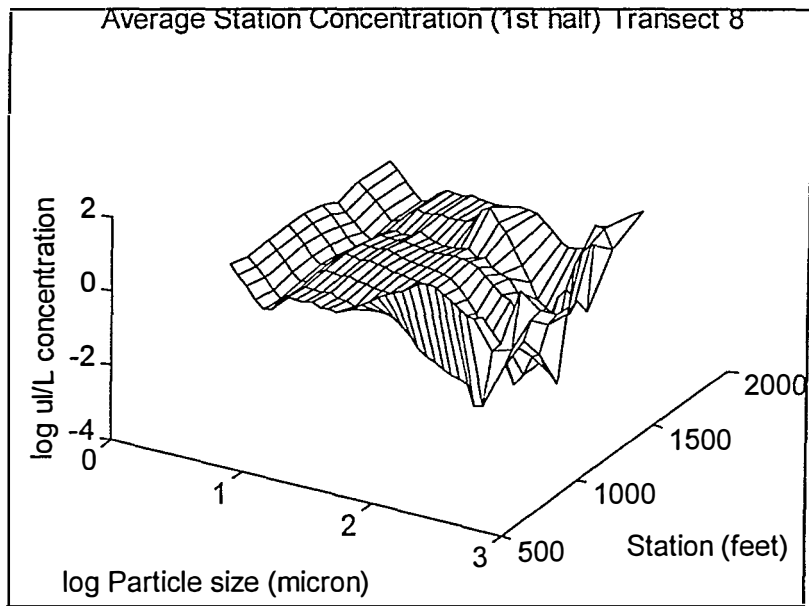
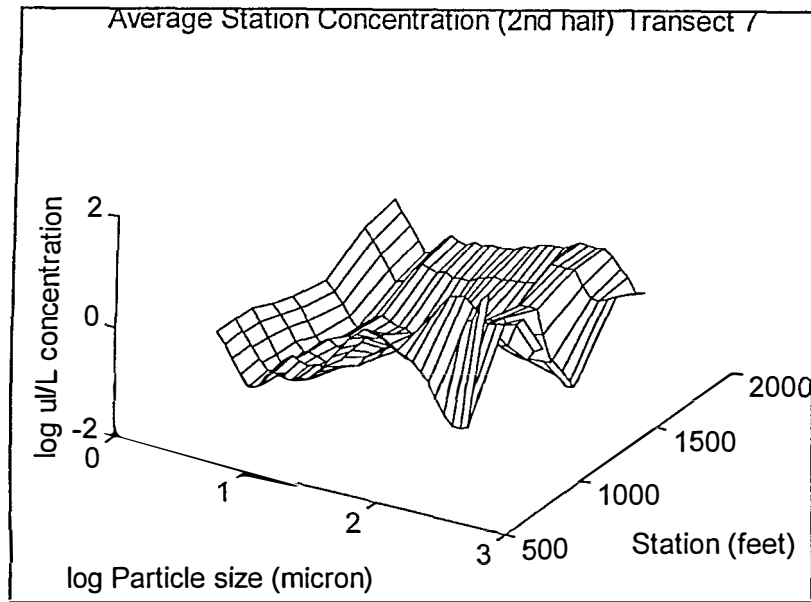
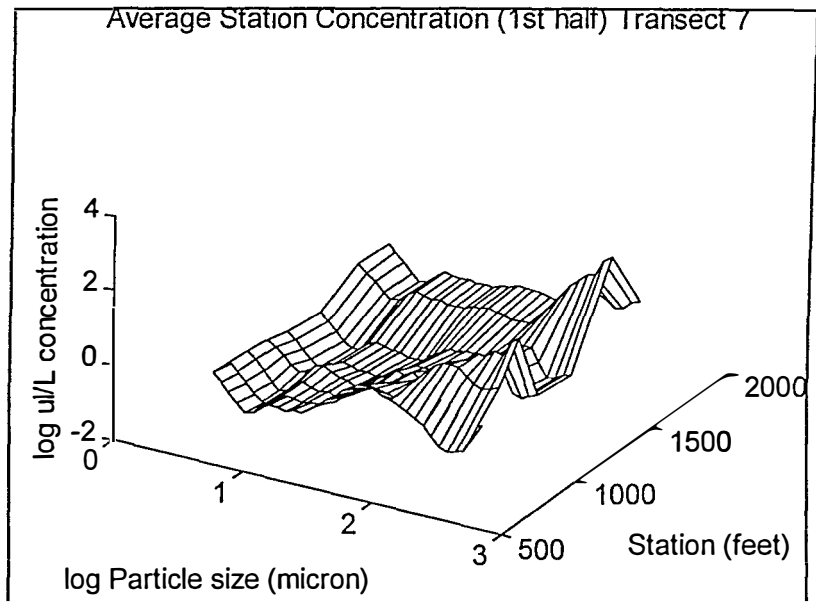

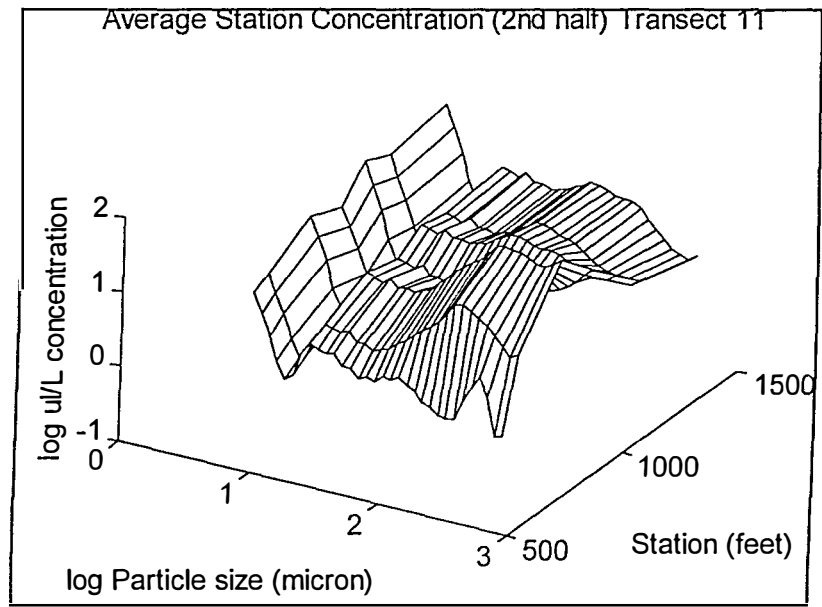
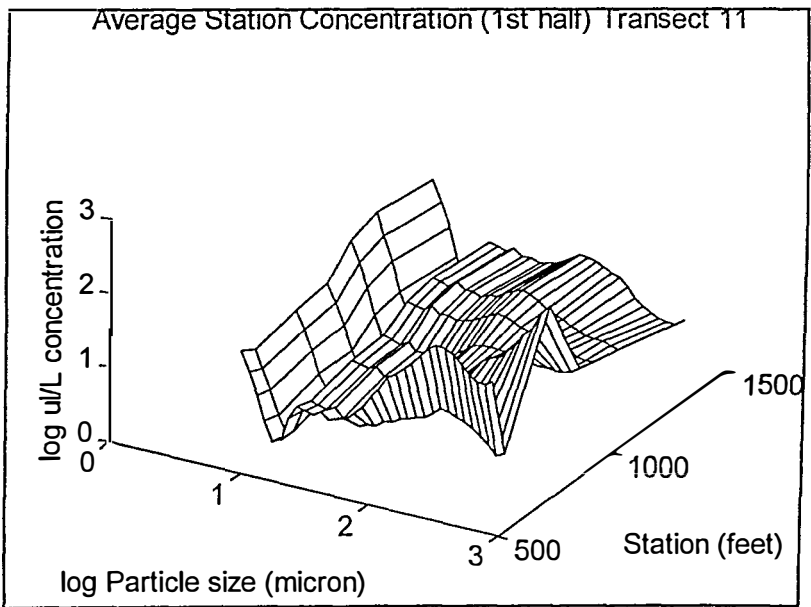
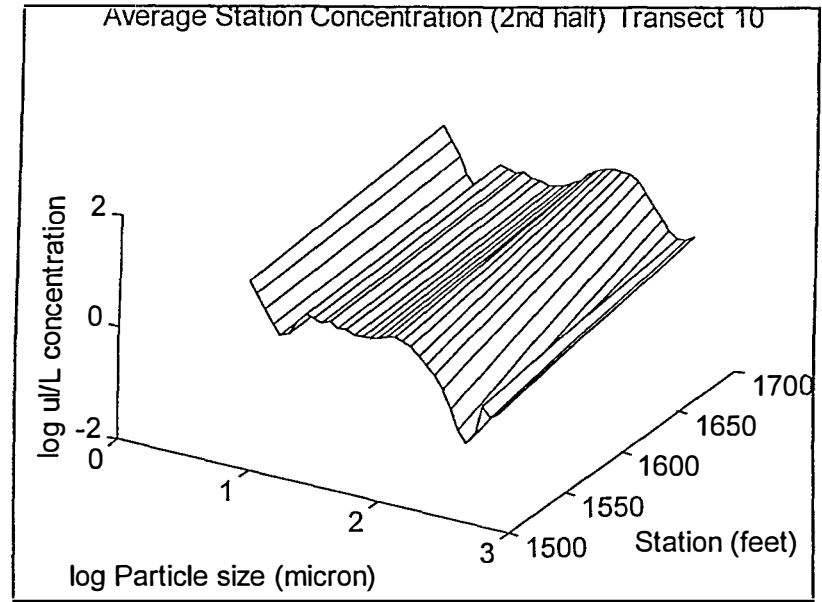
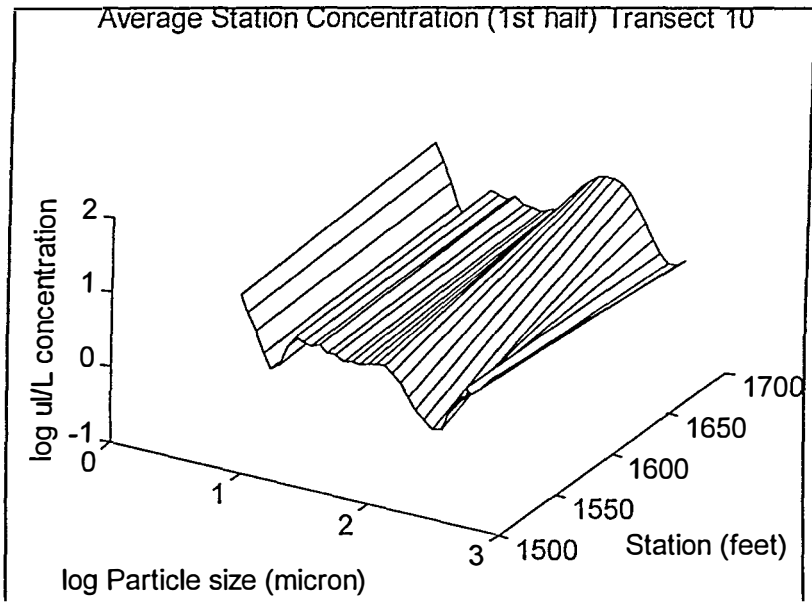

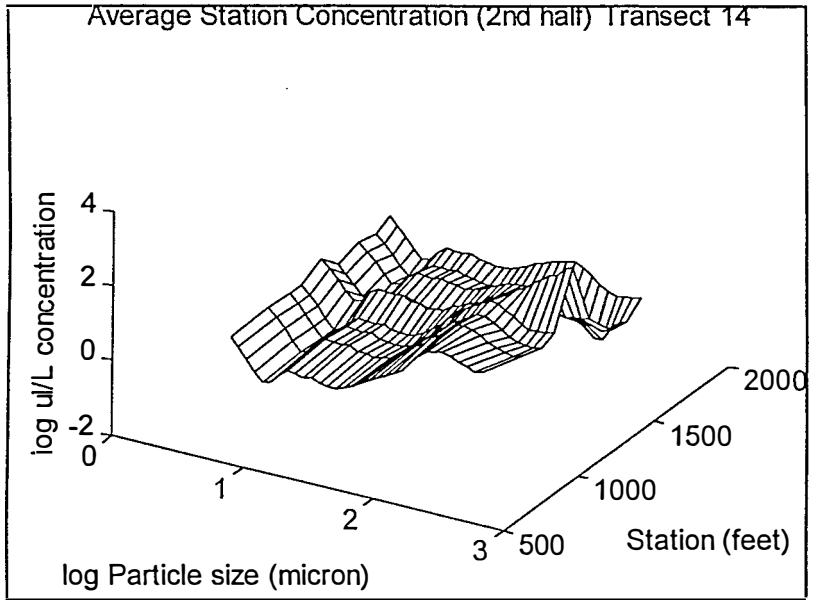
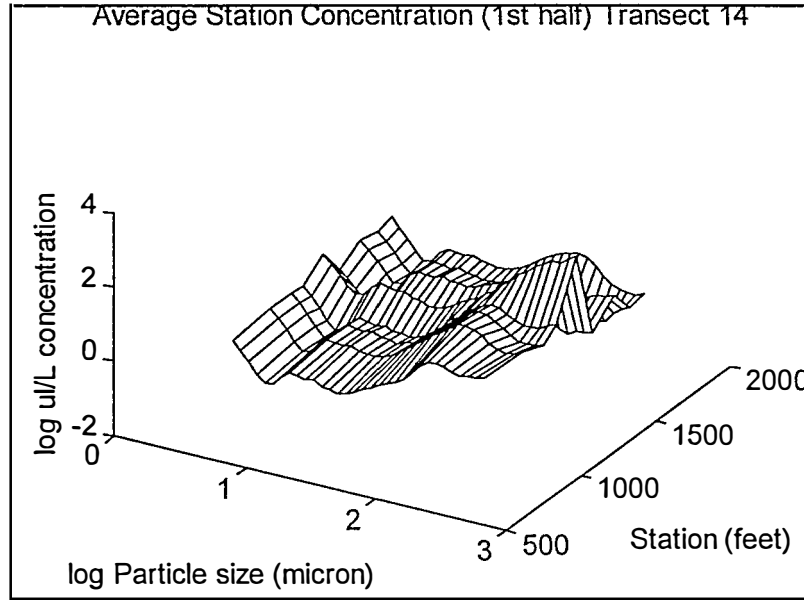
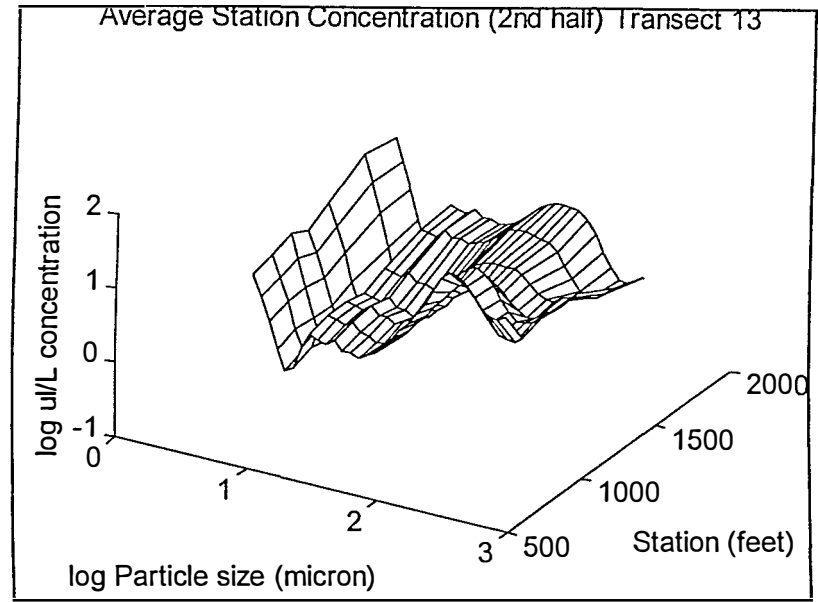
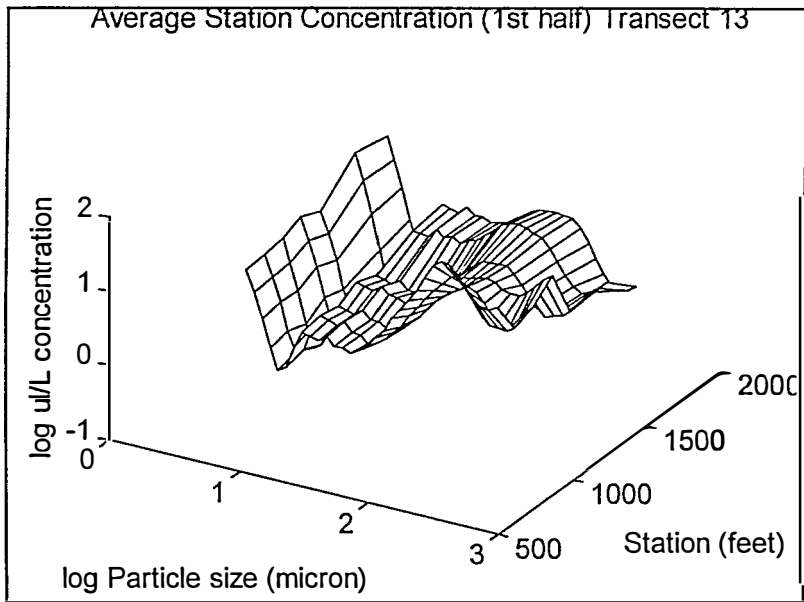

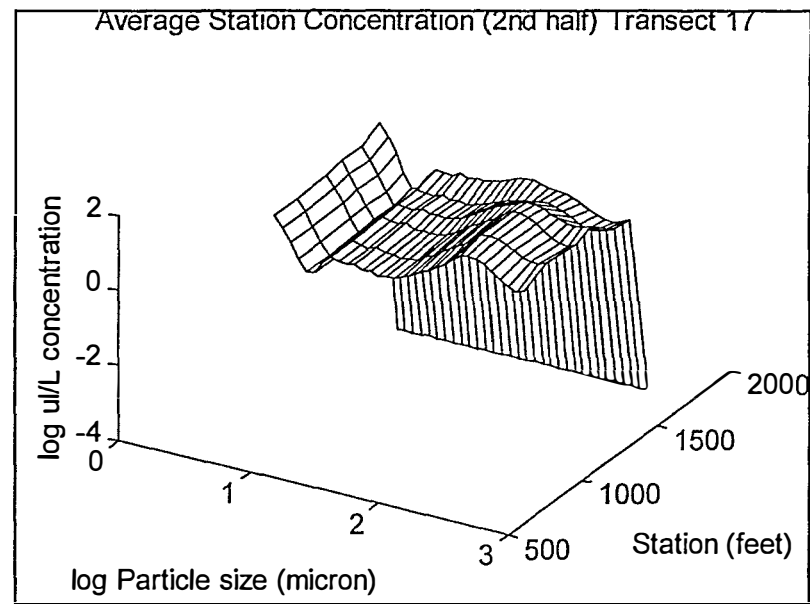
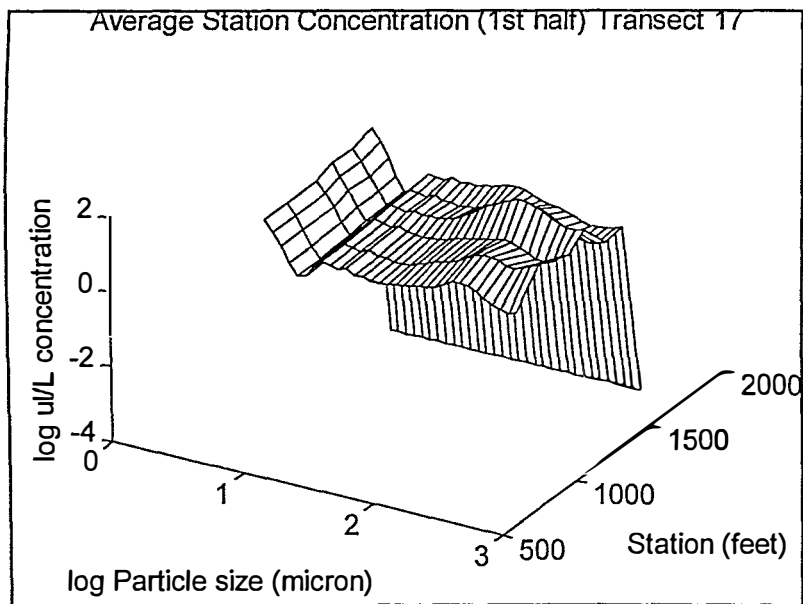
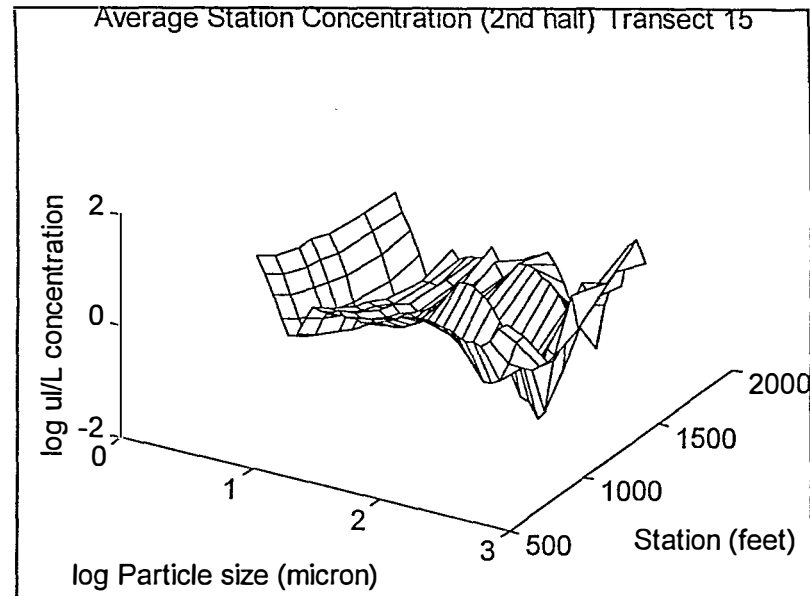
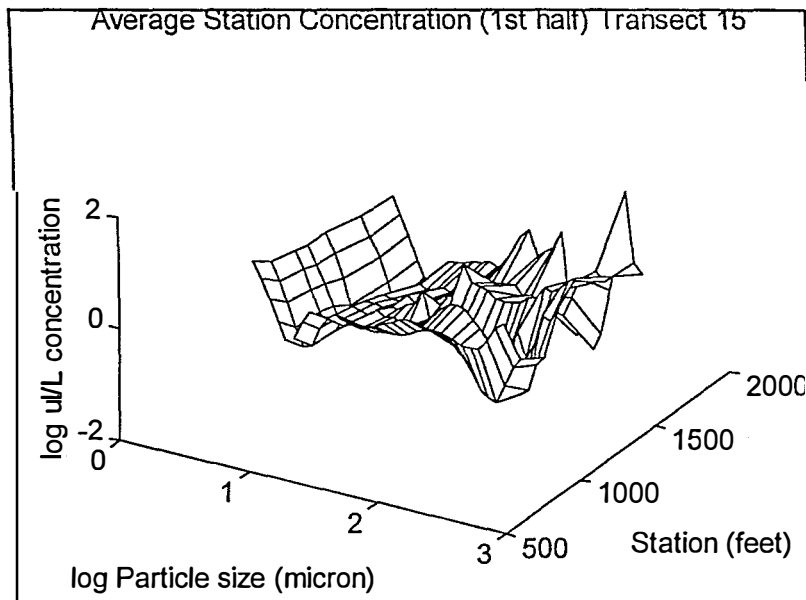

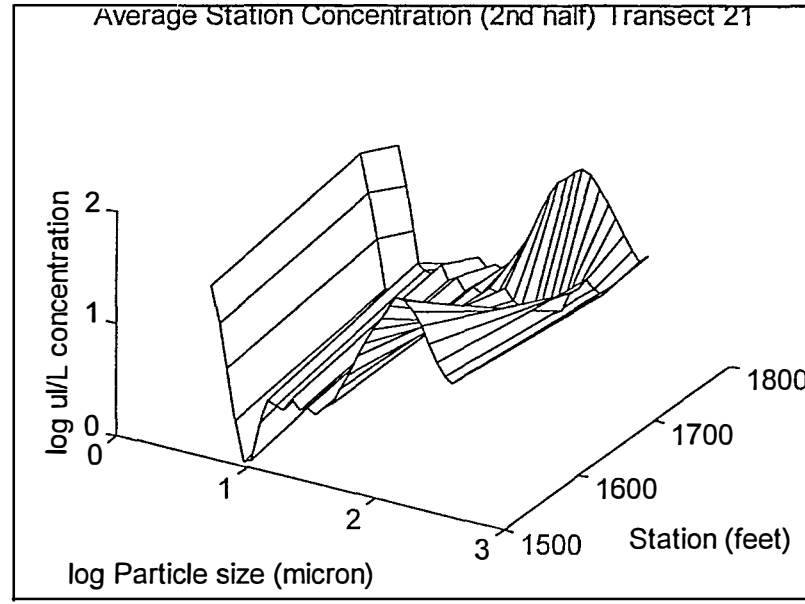
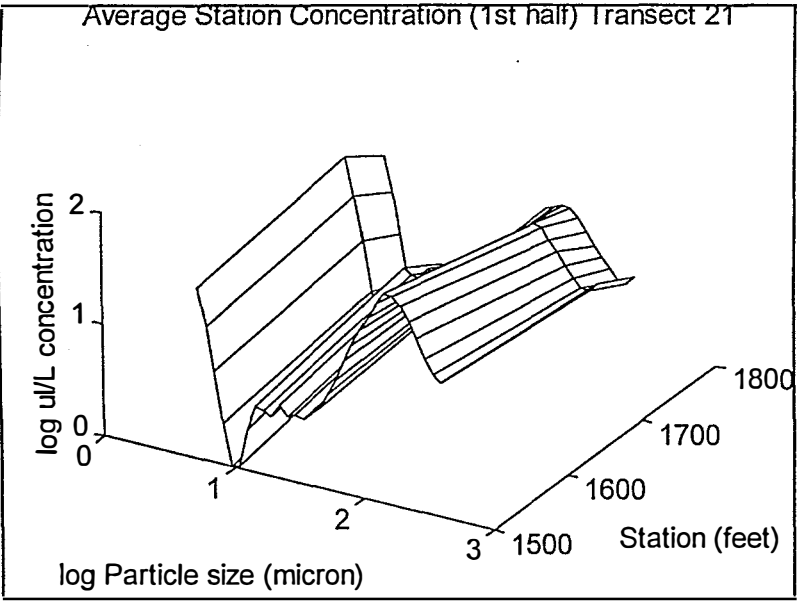
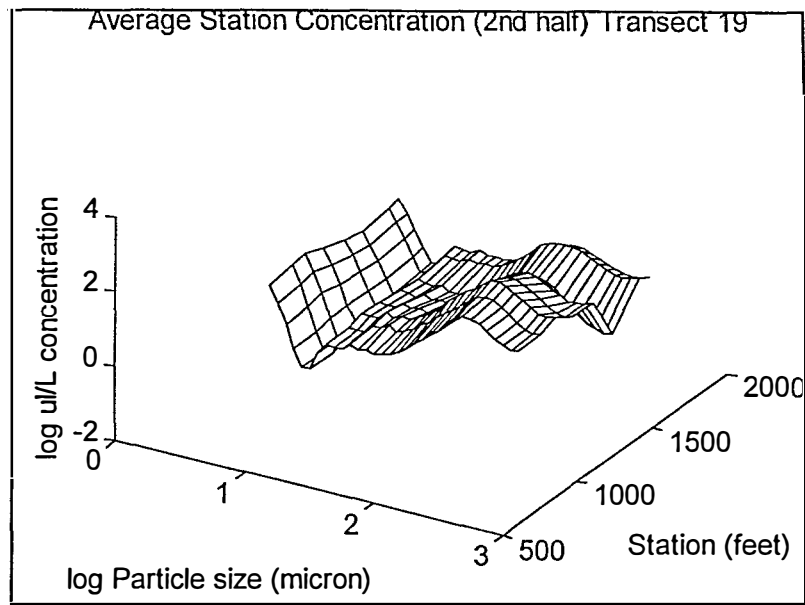
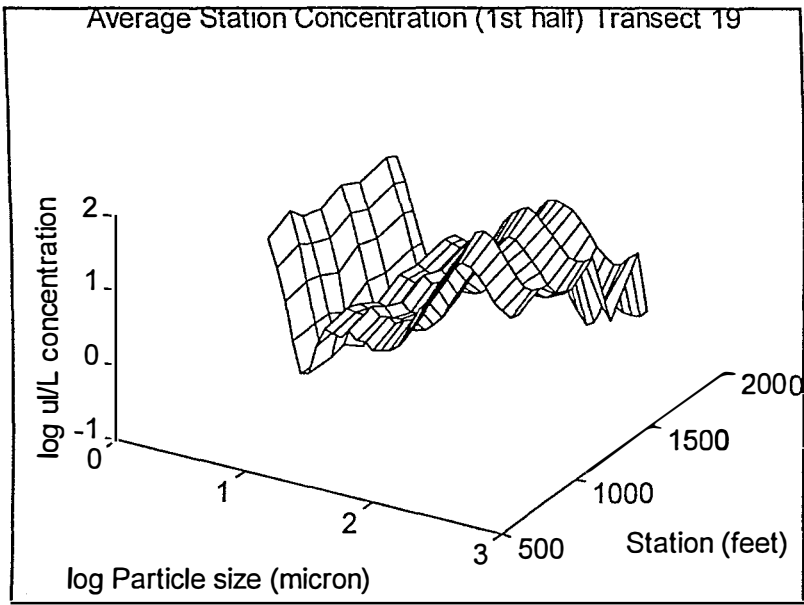

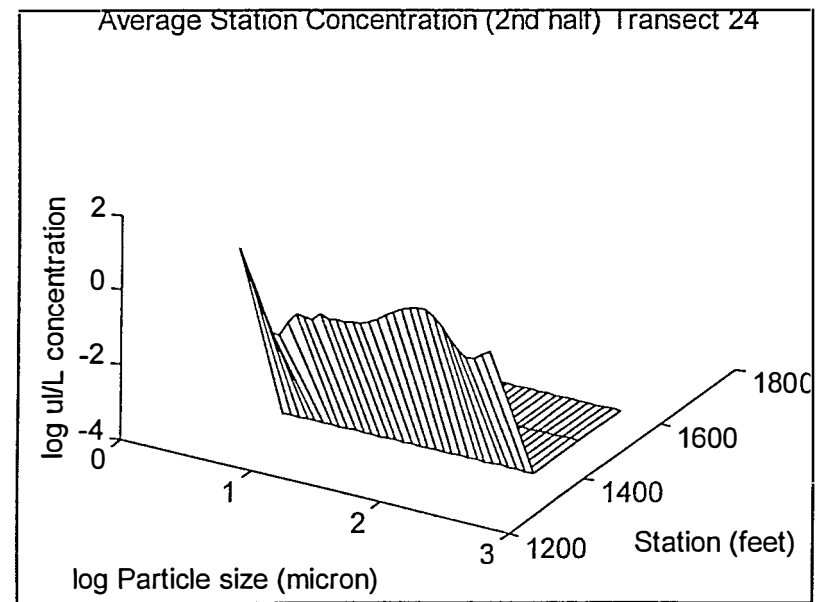
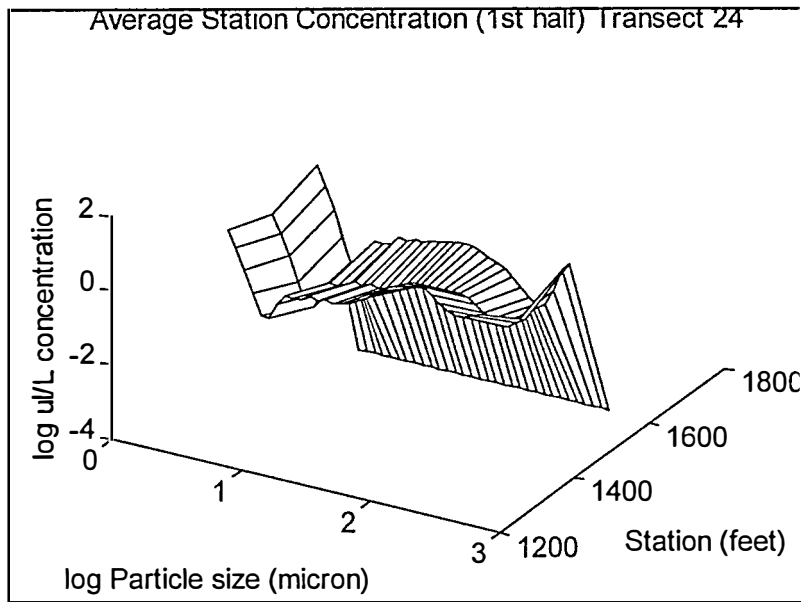
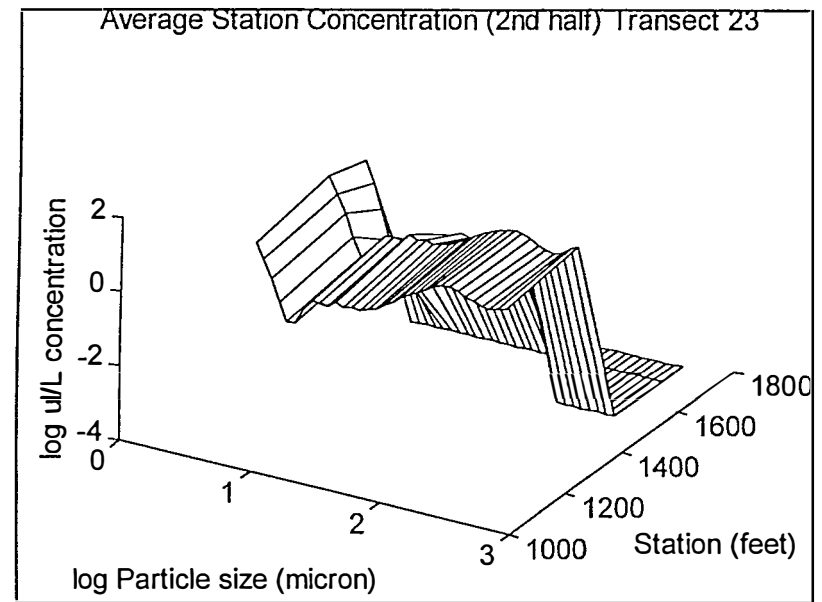
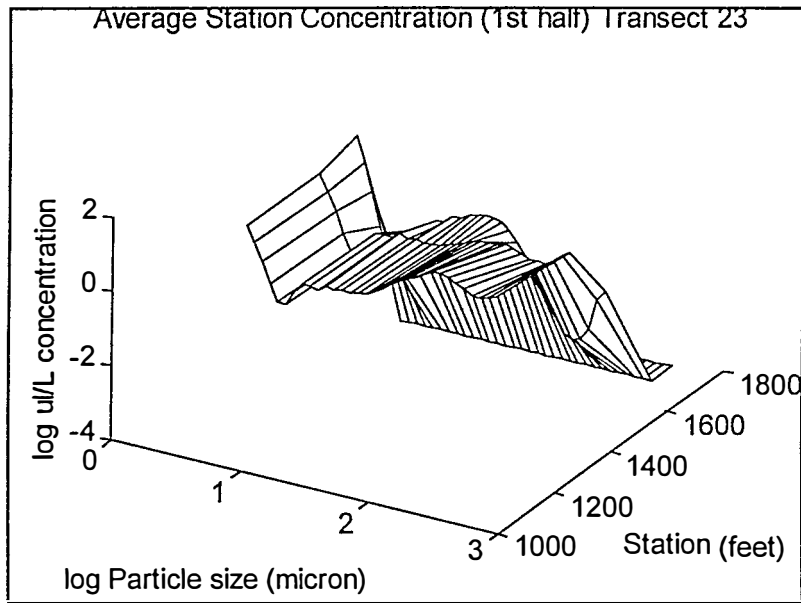

Average Station Concentration (1st half) Transect 26

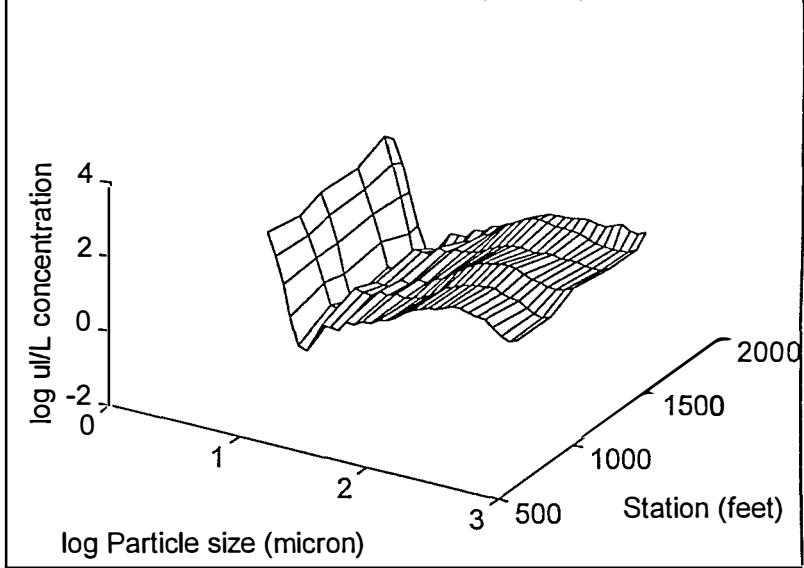

Average Station Concentration (2nd half) Transect 26

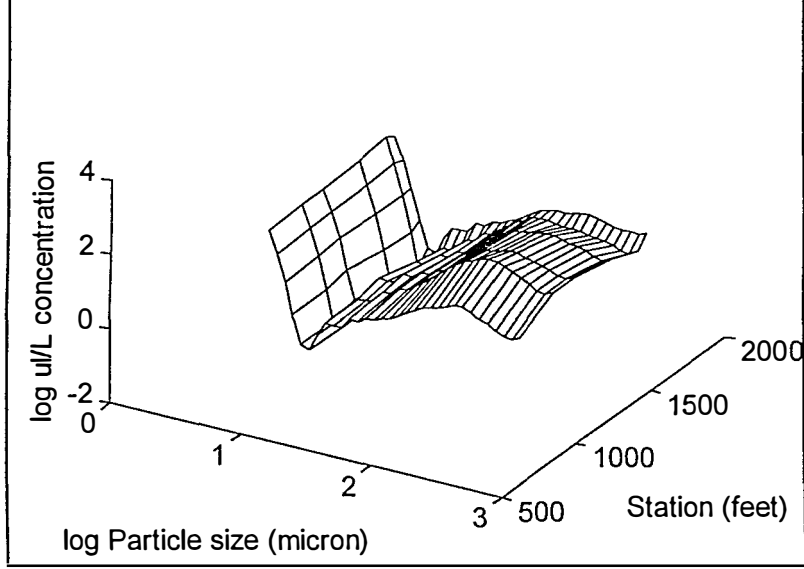

Average Station Concentration (1st half) Transect 27

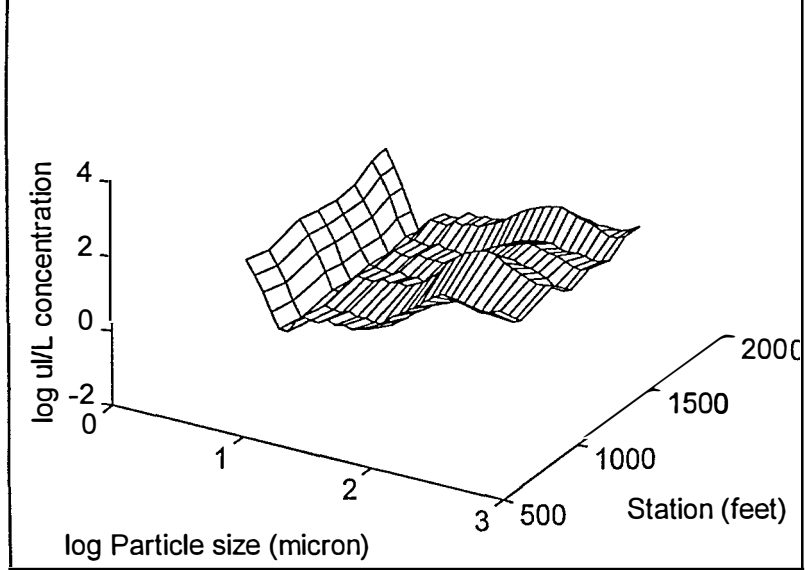

Average Station Concentration (2nd half) Transect 27

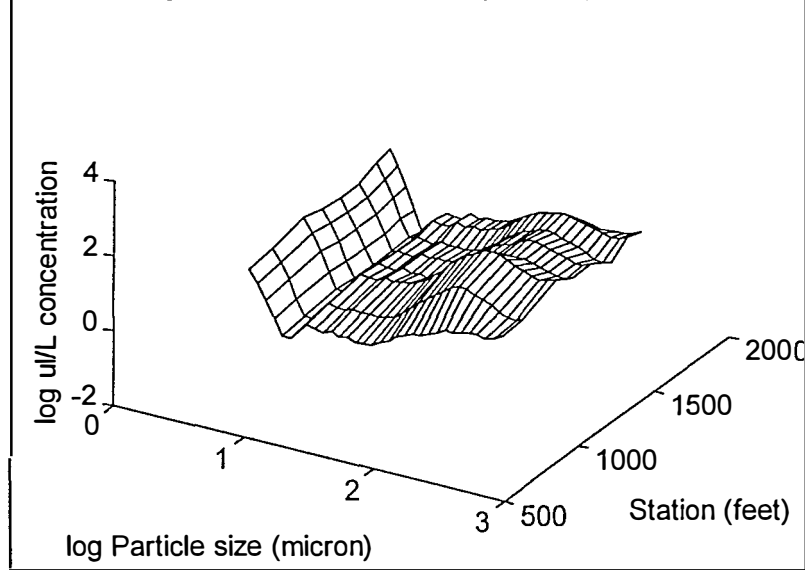

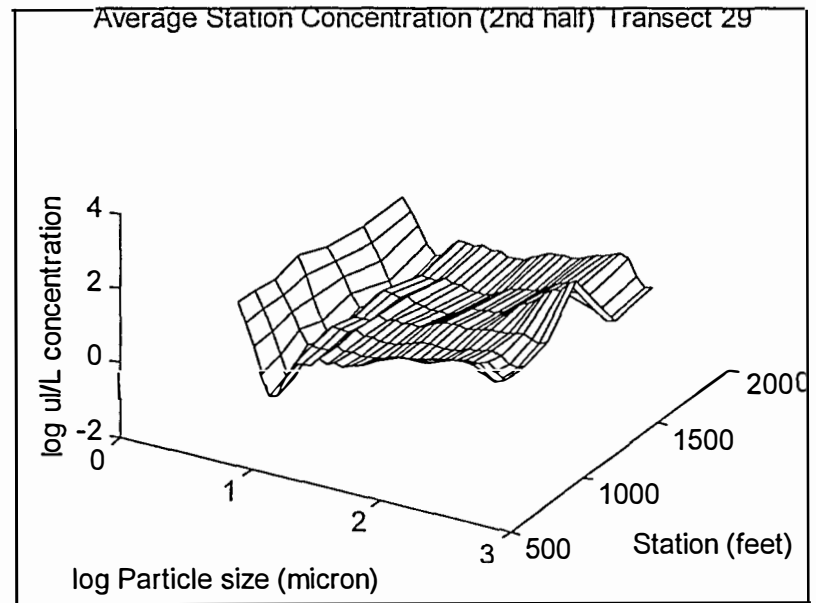
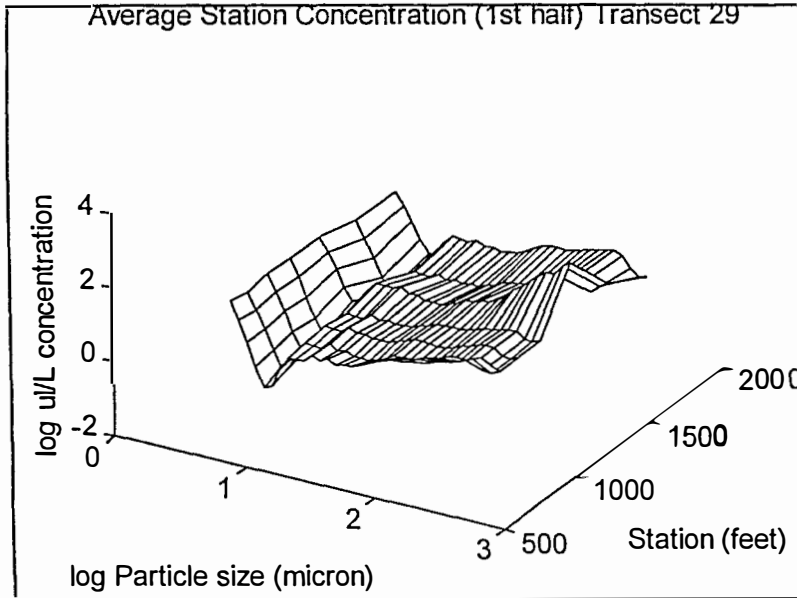
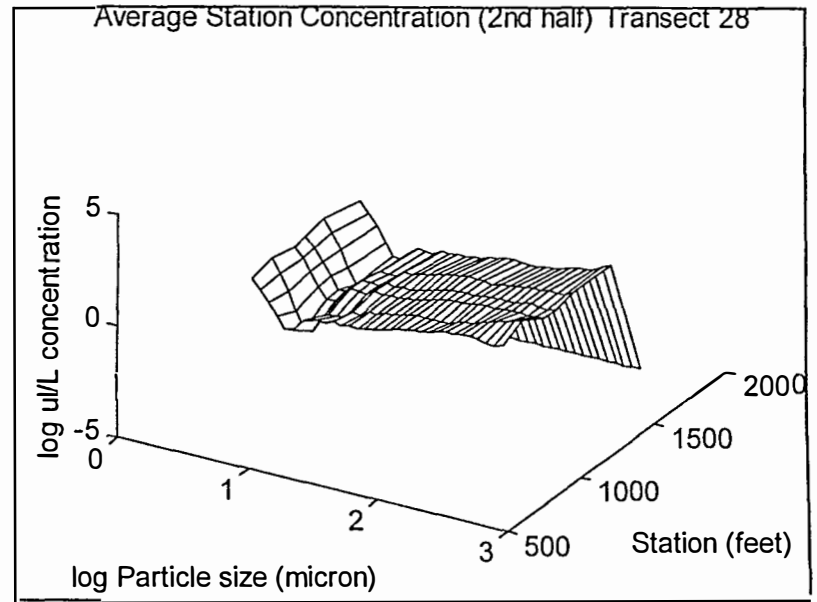
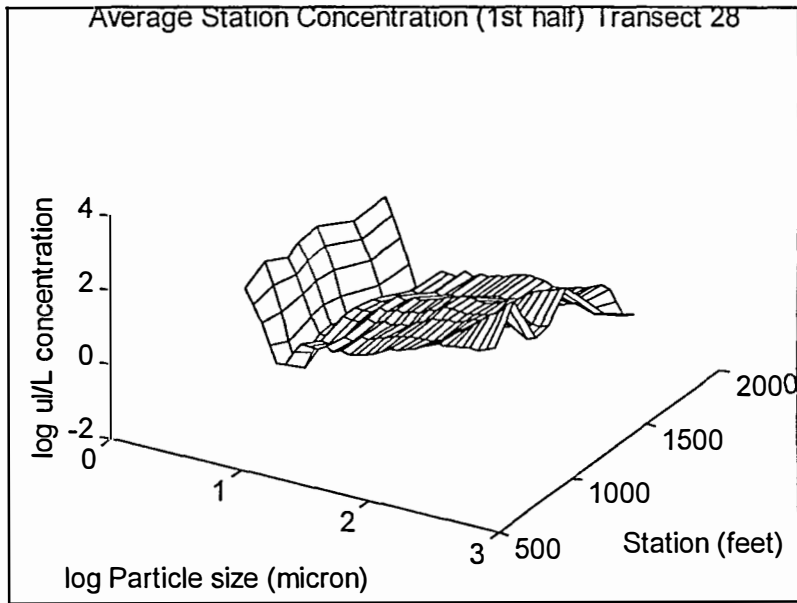

## Section 3

3 1/2 minute averages  
of LISST Time Series  
for each Station  
as a function of Transect

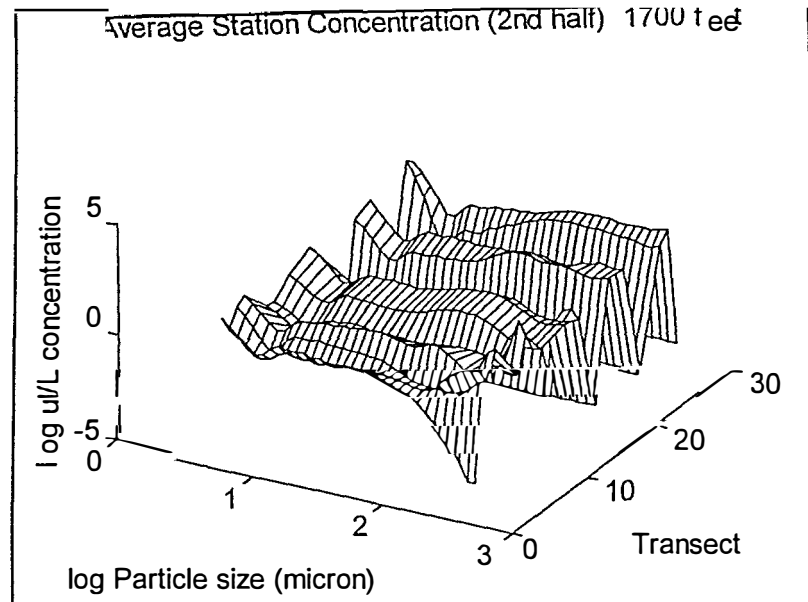
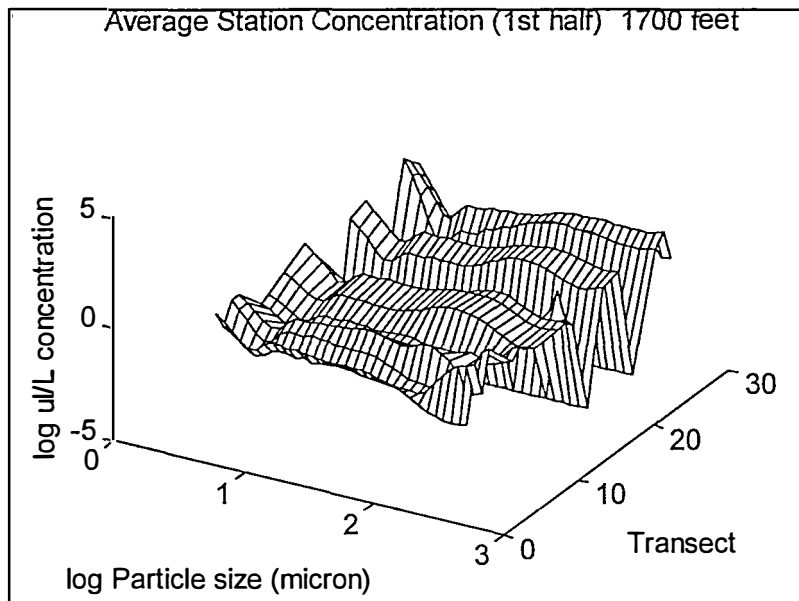
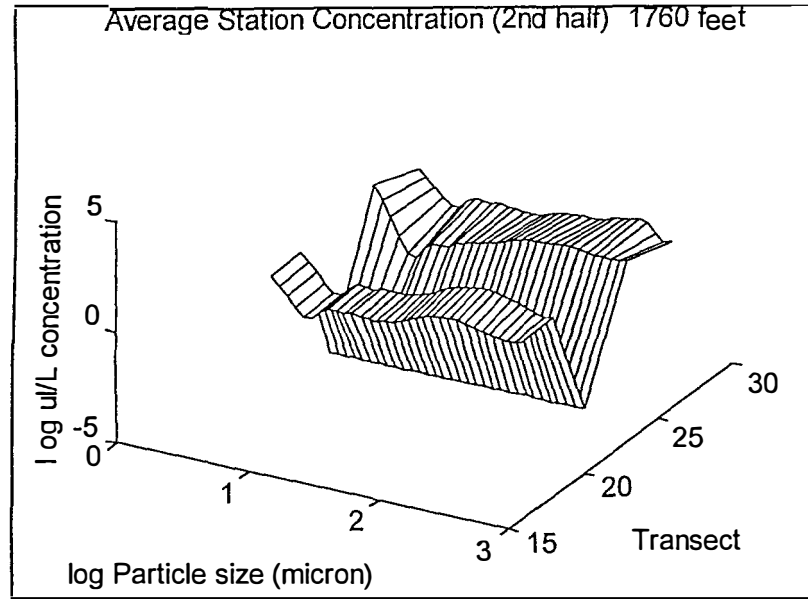
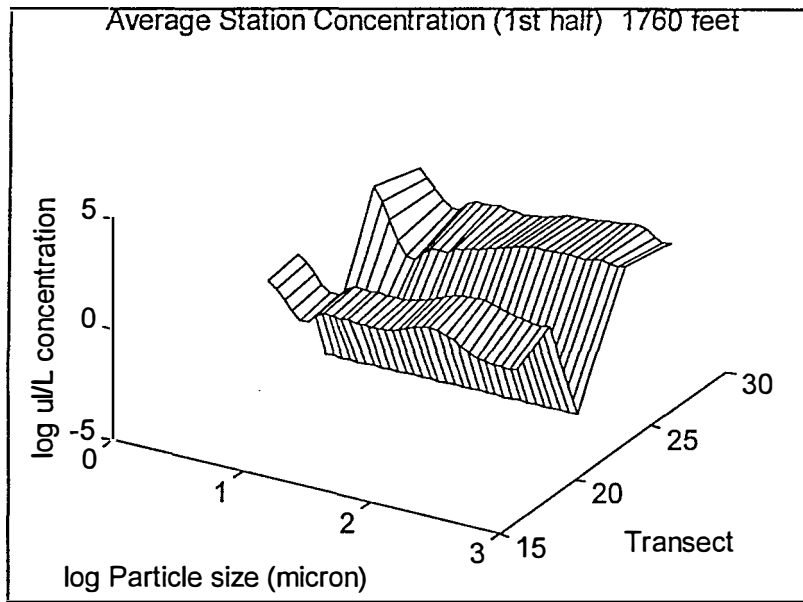

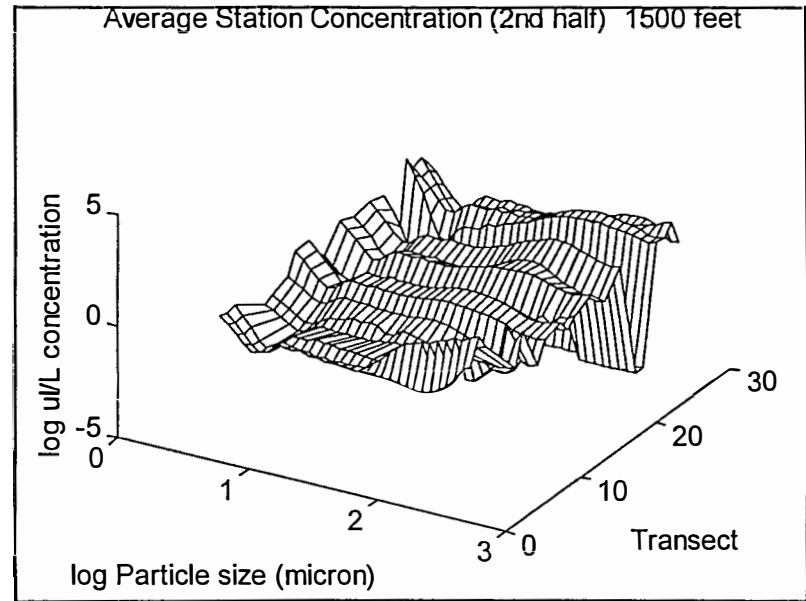
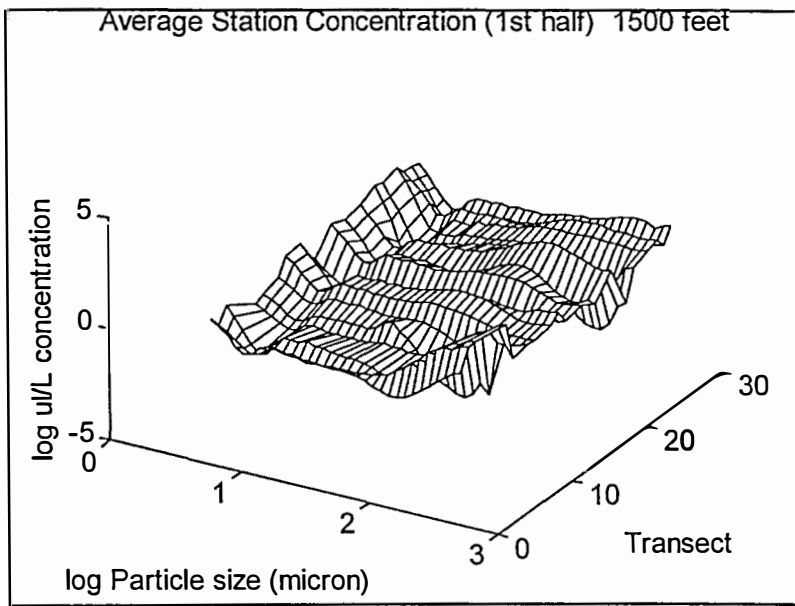
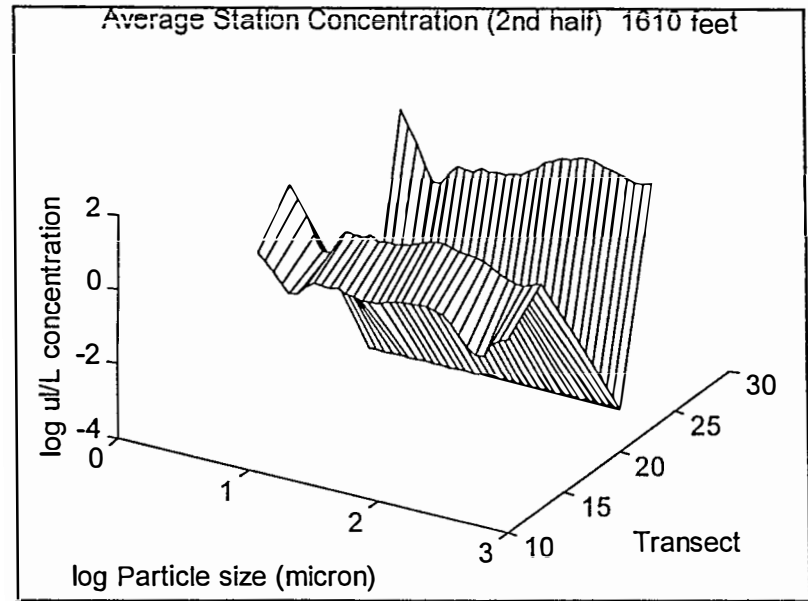
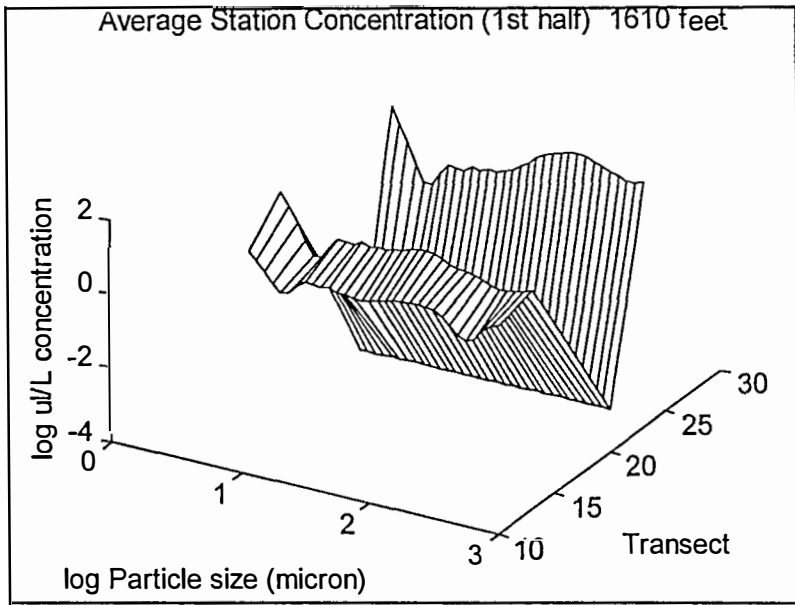

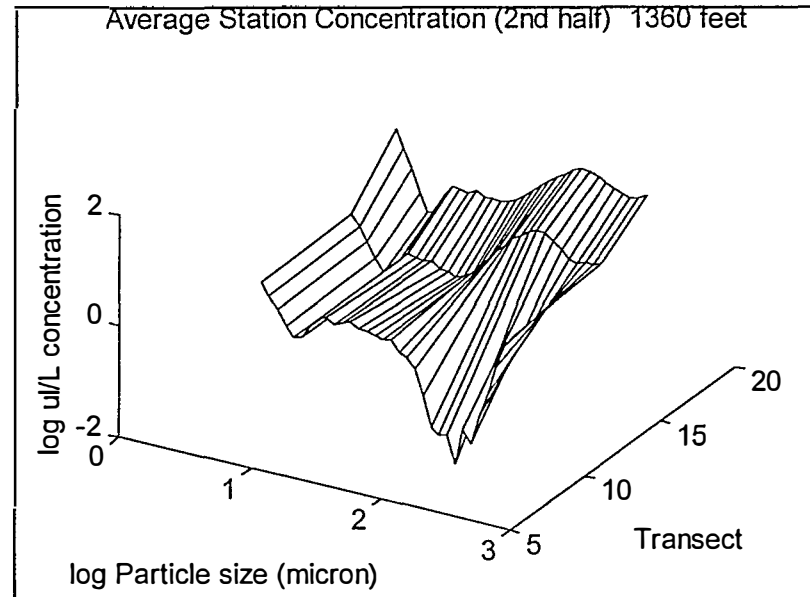
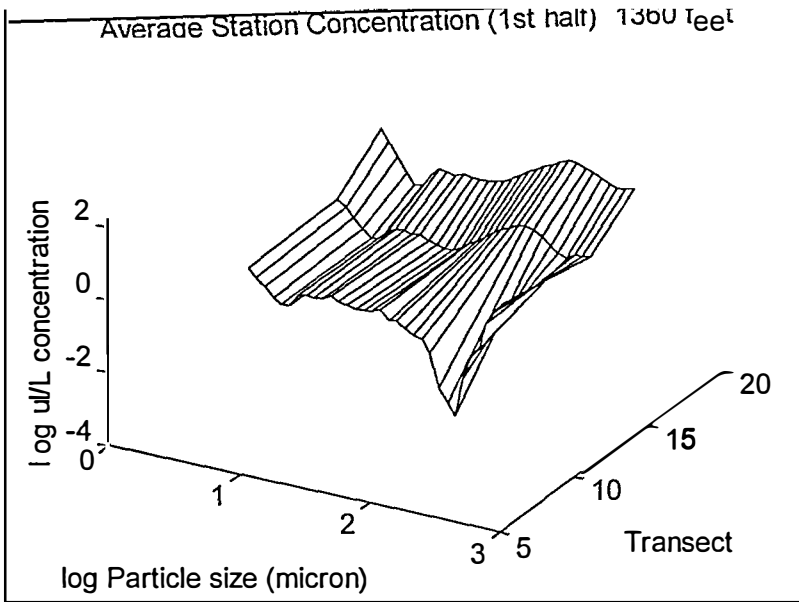
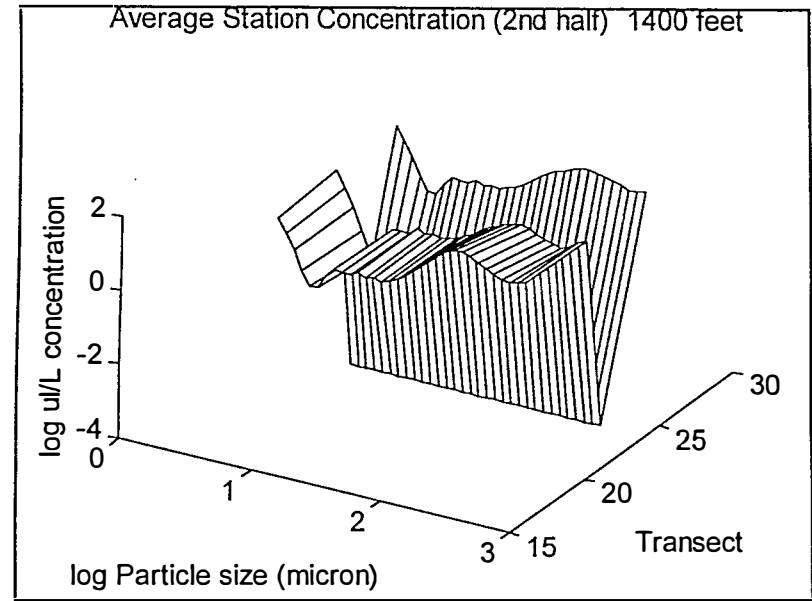
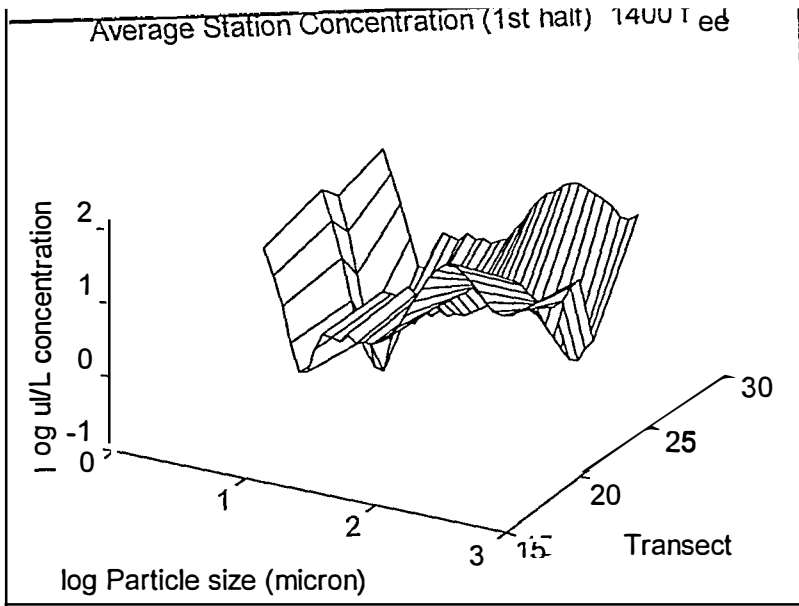

Average Station Concentration (1st half) 1260 feet

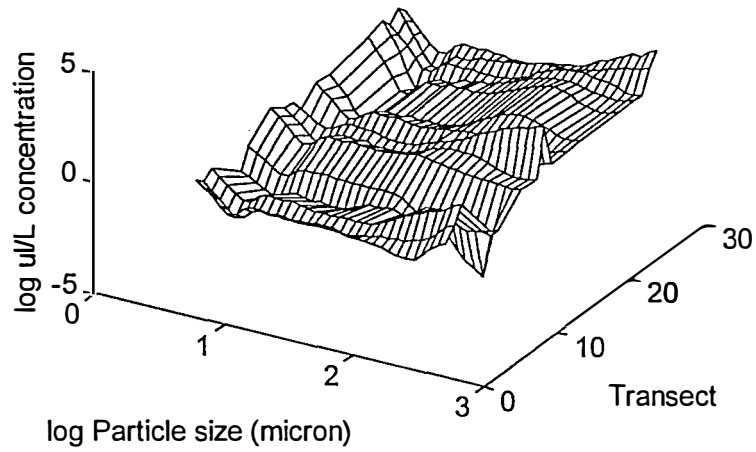

Average Station Concentration (2nd half) 1260 feet

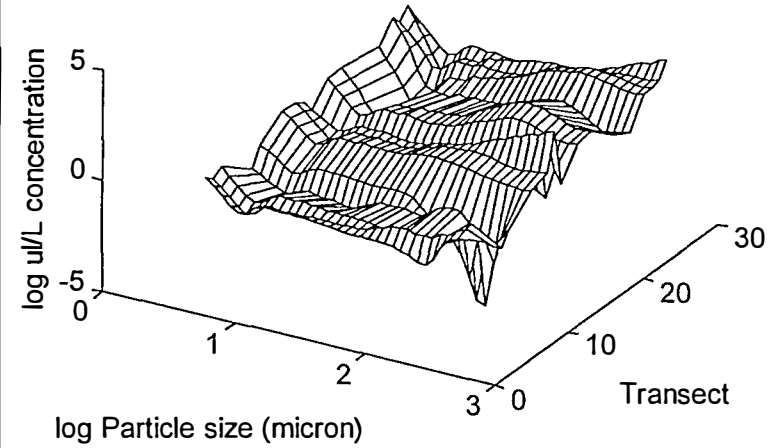

Average Station Concentration (1st half) 1140 feet

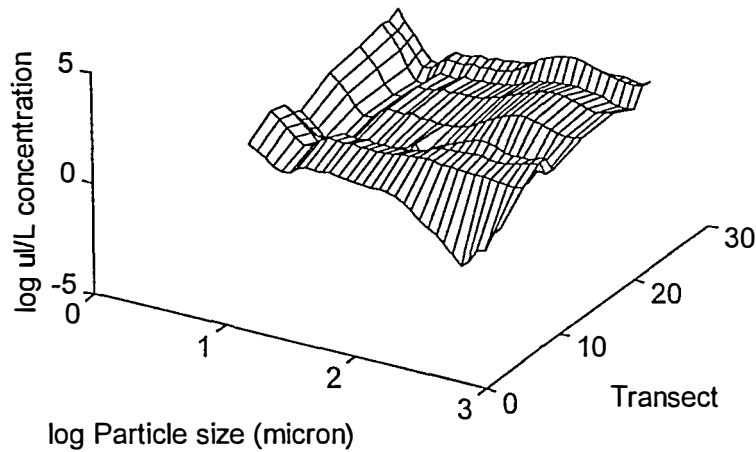

Average Station Concentration (2nd half) 1140 feet

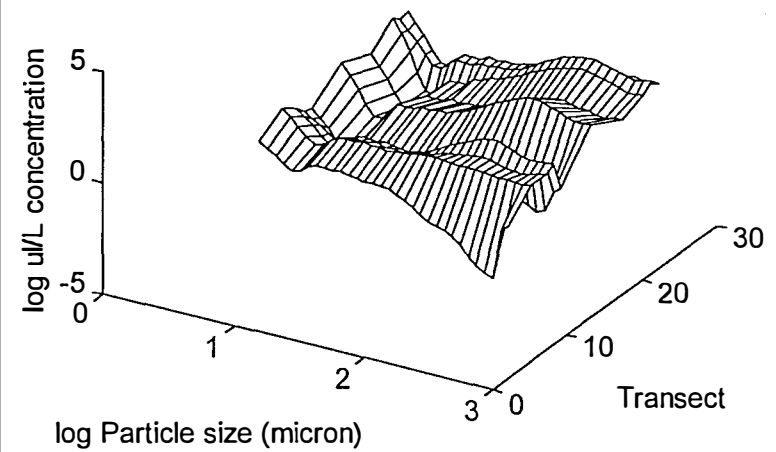

Average Station Concentration (1st half) 1040 feet

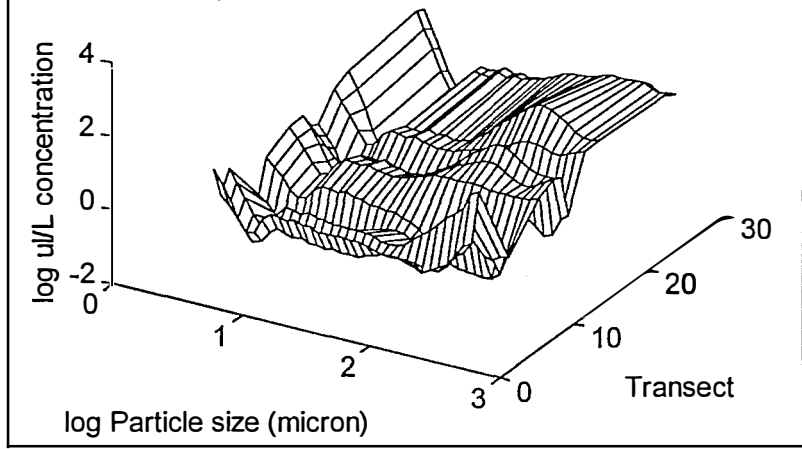

Average Station Concentration (2nd half) 1040 feet

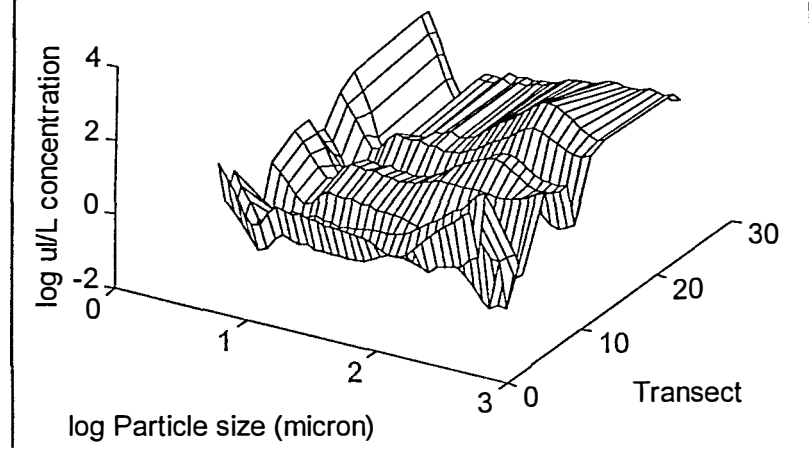

Average Station Concentration (1st half) 900 feet

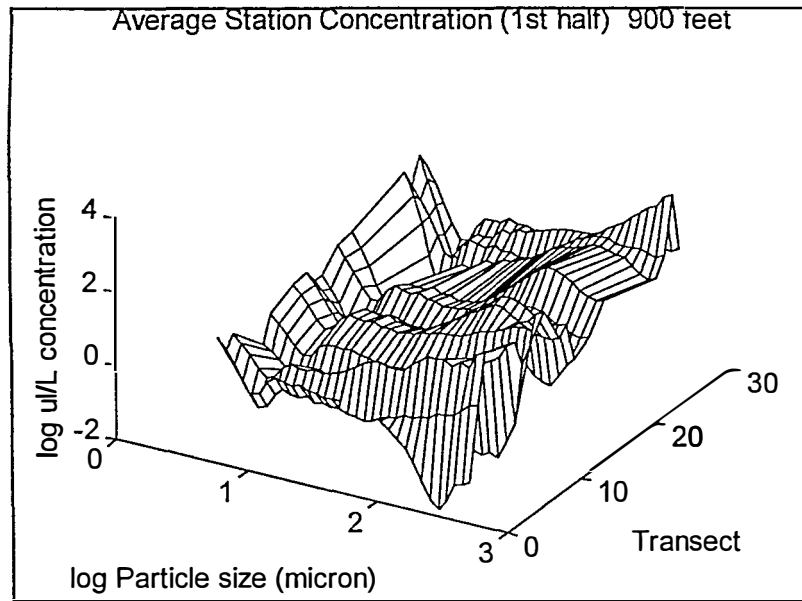

Average Station Concentration (2nd half) 900 feet

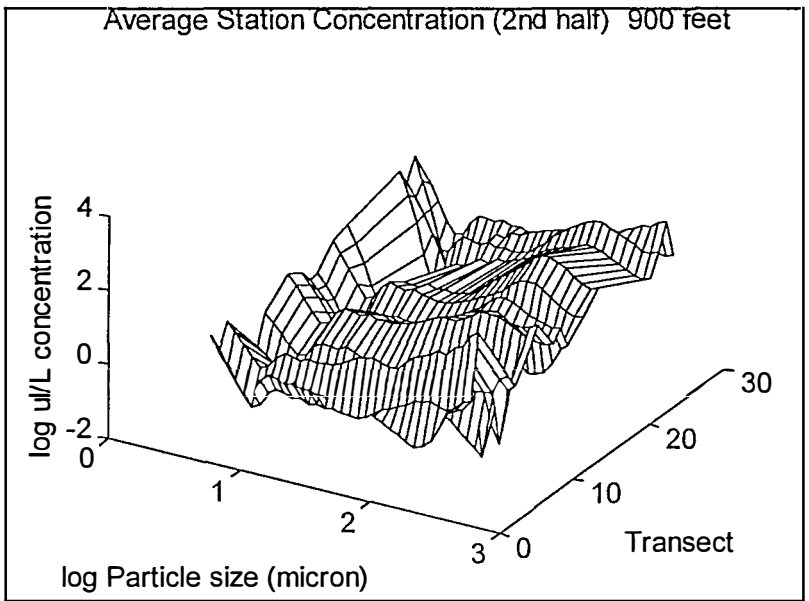

Average Station Concentration (1st half) 770 feet

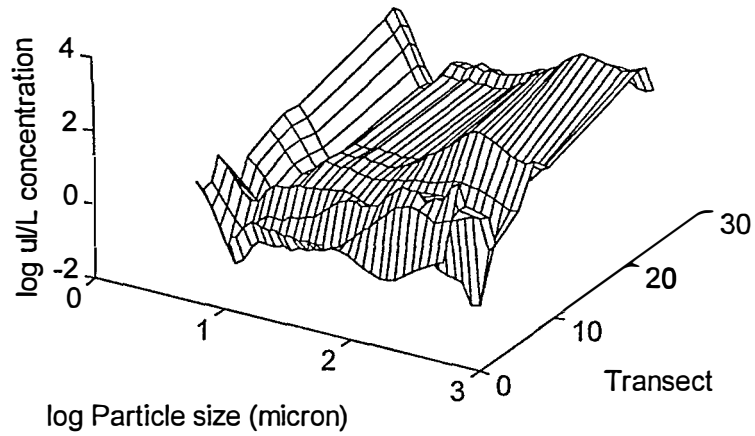

Average Station Concentration (2nd half) 770 feet

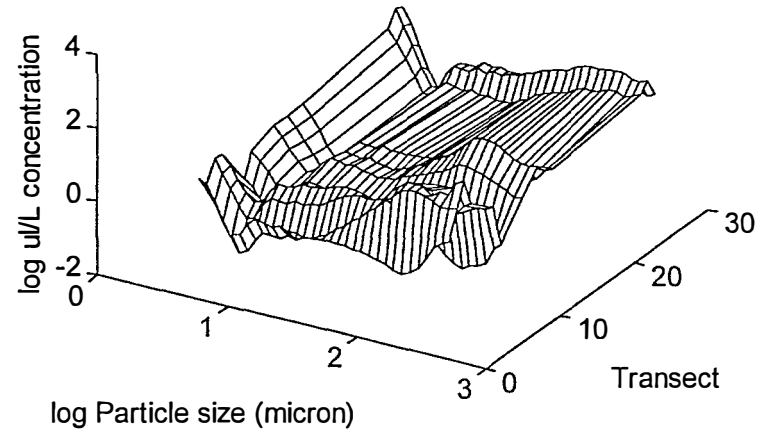

Average Station Concentration (1st half) 650 feet

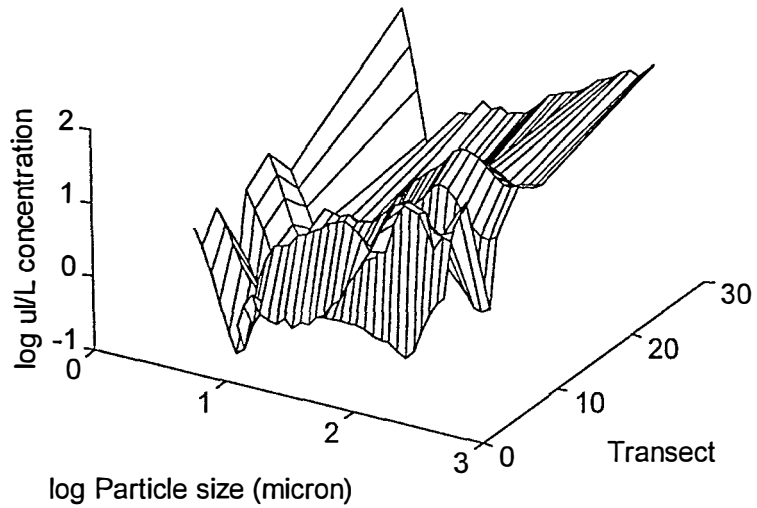

Average Station Concentration (2nd half) 650 feet

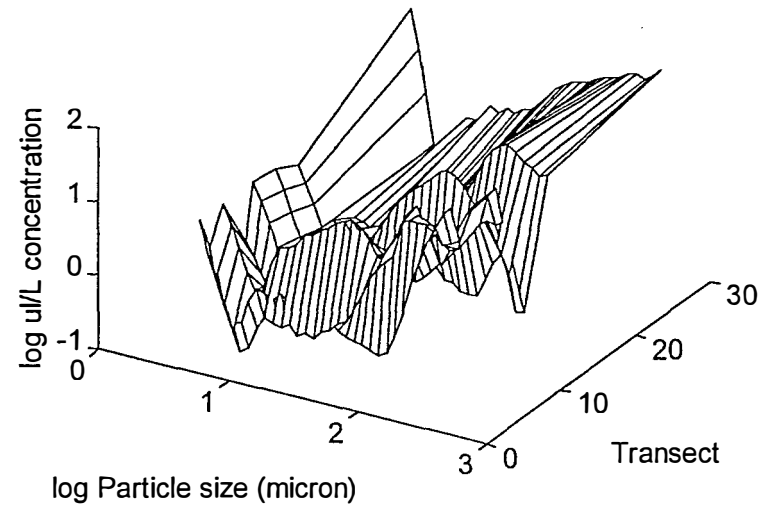

Average Station Concentration (1st half) 540 feet

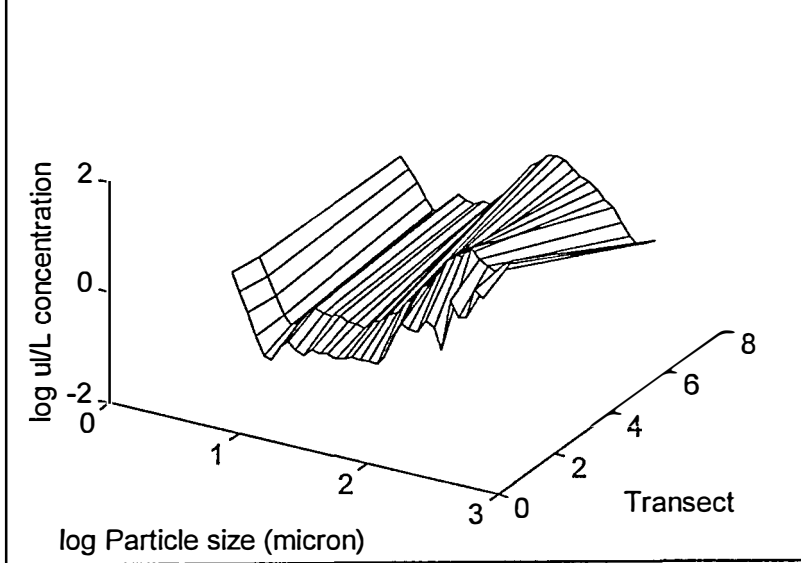

Average Station Concentration (2nd half) 540 feet

