

ple, Sieburth (1963) has used this screen collection technique to study the abundance of bacteria in oceanic surface films.

WILLIAM D. GARRETT

U.S. Naval Research Laboratory,
Washington, D.C.

REFERENCES

- BLANCHARD, D. C. 1964. Sea-to-air transport of surface active material. *Science*, **146**: 396-397.
- DAVIES, J. T., AND E. K. RIDEAL. 1963. *Interfacial phenomena*, 2nd ed. Academic, New York. 480 p.
- GARRETT, W. D., AND J. D. BULTMAN. 1963. Capillary-wave damping by insoluble organic monolayers. *J. Colloid Sci.*, **18**: 798-801.
- JARVIS, N. L. 1962. The effect of monomolecular films on surface temperature and convective motion at the water/air interface. *J. Colloid Sci.*, **17**: 512-522.
- SIEBURTH, J. MCN. 1963. Abundance of bacteria in oceanic surface films. *Bacteriol. Proc.* 1963, p. 2. Abstr. A8 63rd Annual Meeting, American Soc. Microbiol., Cleveland, Ohio.

APPARATUS FOR HOLDING INDIVIDUAL OYSTERS UNDER EQUAL WATER FLOWS¹

An apparatus (Fig. 1) has been developed for holding individual oysters, *Crassostrea virginica*, under conditions of equal water flow in studies of filtration rates, growth, and fecal production. Its operation is based on maintenance of a constant pressure head by continuous overflow from a central tube. Water flows to individual compartments around the tube through holes of equal diameter. It is designed to hold 5-cm oysters under volume flows that do not limit shell growth and tissue development, and can be modified to hold other organisms as well. Apparatus designed to hold marine organisms under known flows are widely used (Clark and Clark 1964), but a compact unit similar in design to the present one has not been previously developed.

The apparatus is constructed of 0.3-cm acrylic plastic sheets and cylinders cemented together. A central cylinder 4.5-cm I.D. has 8 equally spaced feeder holes, 0.25-cm diameter, around its periphery. These holes, 10.8 cm above the base, open into an equal number of holding compartments. The outside edges of the compartments are enclosed by a cylindrical section 30-cm I.D., 9.5 cm high. The base is a 37-cm square plate. Each individual compartment has 4 vertical baffles arranged to control water flow pattern (Fig. 2). A vertical separator

in the bottom allows separate accumulation of oyster feces and pseudofeces as described by Lund (1957).

Water flows in at the top of the central cylinder through a glass tube (1.0-cm I.D.) extending to within 2.6 cm of the bottom. Water overflows continuously from the cylinder through a large-bore glass tube (0.8-cm I.D.) inserted into a 2.6 cm hole (drilled at a measured height above the plane of the feeder holes) and extending beyond the outer edge of the compartments.

The initial and most exact operation required in construction is drilling the holes

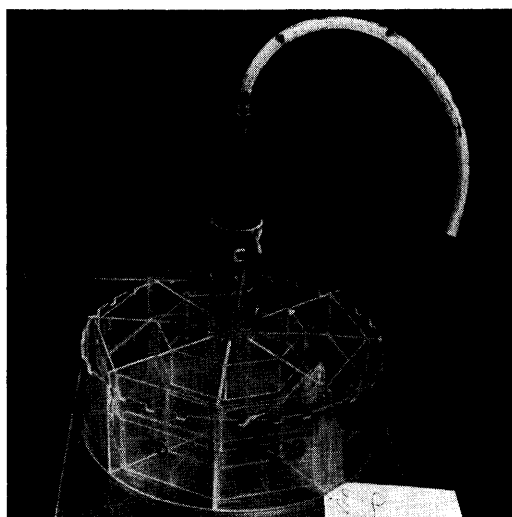

FIG. 1. Photograph of apparatus showing water inflow tube at top and overflow tube to one side. Height to base of notches is 9.5 cm.

¹ Contribution No. 198, Virginia Institute of Marine Science. Apparatus developed under U.S. Atomic Energy Commission Contract No. AT-(40-1)-2789.

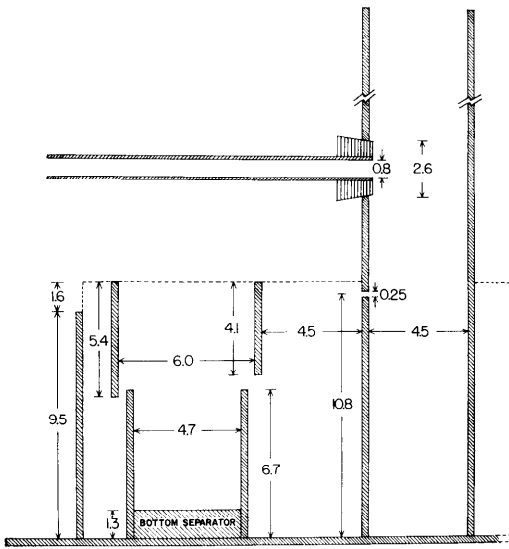

FIG. 2. Cross section of a compartment showing arrangement of baffles. Measurements are in cm.

in the central cylinder. This should be done with precision equipment so that all bores are at right angles to the long axis of the cylinder with the holes exactly the same diameter and distance from the base. The base of the cylinder should be cut so that it will rest perpendicular to the basal plate. All cylinders are cut and drilled at the same time to insure uniformity.

Prior to assembly of the units, the central cylinders are cemented to the basal plate and tested. Replicate measurements of flow rate from each feeder hole are made for each of the water column heights as determined by the height of the overflow tube. Water level in each case is raised to the center of the overflow hole and a permanent mark made on the cylinder. Overflow holes not in use are plugged. Units with significant differences in flow rates are discarded.

Spacing of the baffles is important if the apparatus is used to collect oyster feces or pseudofeces; for example, the present design gives a slow even flow of water over the oyster in the upper quarter of each compartment and a very slow flow in the

lower quarter. This design prevents flushing of the biodeposits from the trough before they settle. In units used to hold other organisms, baffles may be eliminated or modified. Construction and assembly is greatly simplified by the use of wooden templates and spacers.

Test of flows from 10 units constructed at our laboratory gave the following results: With the overflow tube draining the central cylinder 16.5 cm from the base, the mean flow out of the individual feeder holes is 202 ml/min, with a coefficient of variation of 2.78%. Mean total flow out of each unit (8 feeder holes) is 1.62 liter/min, with a coefficient of variation of 1.23%.

In operation, single oysters are suspended in each compartment with a wire stirrup. They lie flat on one valve, oriented umbo down with the bill projecting slightly above the holding chamber. Since feces and pseudofeces are ejected separately on opposite sides of the shell cavity they also accumulate separately on opposite sides of the bottom separator plate. Deposits are collected by suction with a bulb aspirator, washed free of salt, dried, and weighed. Quantities collected can be related to flow volume.

Daily maintenance consists of adjusting flow into the central cylinder with a screw clamp so that the water level is at the pre-marked height of overflow. The adjustment is minimal, since flow from the water supply into the unit can fluctuate over fairly wide limits without significant changes in level in the central cylinder. A pipe cleaner is used to clean the feeder holes daily.

DEXTER S. HAVEN
R. MORALES-ALAMO

*Virginia Institute of Marine Science,
Gloucester Point, Virginia.*

REFERENCES

- CLARK, J. R., AND R. L. CLARK [eds.]. 1964. Sea-water systems for experimental aquariums. U.S. Fish Wildlife Serv., Res. Rept. 63. 192 p.
- LUND, E. J. 1957. A quantitative study of clearance of a turbid medium and feeding by the oyster. *Publ. Inst. Marine Sci. Texas*, 4: 296-312.